

1. Mechanical Dimensions:

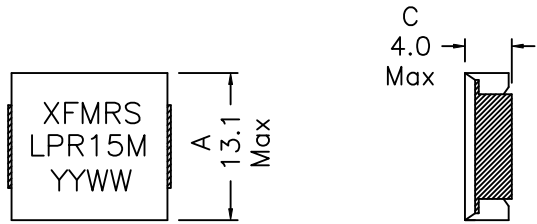

TOP VIEW

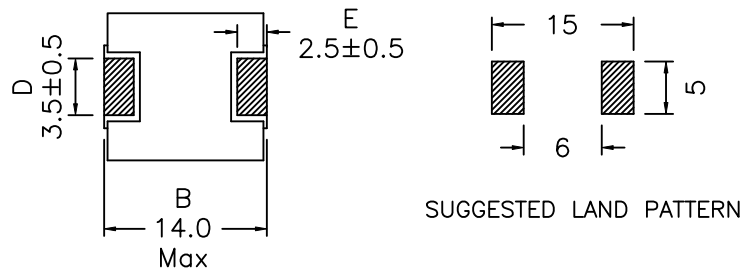

BOTTOM VIEW

SUGGESTED LAND PATTERN

2. Schematic:

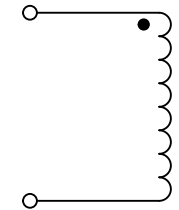

3. Electrical Specifications: @25C

OCL: 0.15uH±20% @100KHz 0.1V

Q: tbd Min @100KHz 0.1V

DCR: 1.2 mOhms Max

Isat: 75Adc (Based on 20% drop in OCL)

Irms: 41Adc (Based on 40°C Temp Rise)

Notes:

1. Solderability: Leads shall meet MIL-STD-202G, Method 208H for solderability.
2. Flammability: UL94V-0
3. ASTM oxygen index: > 28%
4. Insulation System: Class F 155°C. UL file E151556
5. Operating Temperature Range: All listed parameters are to be within tolerance from -55°C to +125°C
6. Storage Temperature Range: -55°C to +125°C
7. Aqueous wash compatible
8. SMD Lead Coplanarity: ±0.004"(0.102mm)
9. Electrical and mechanical specifications 100% tested
10. RoHS Compliant Component

DOC. REV: A/-

XFMRS® www.XFMRS.com	Title: SMT POWER INDUCTOR		
	UNLESS OTHERWISE SPECIFIED TOLERANCES: .xx ±0.25 Dimensions in MM		P/N: XFHCL4LP-R15M
SHT 1 OF 1	DWN.	Feng	Oct-14-21
	CHK.	YK Liao	Oct-14-21
	APP.	NBL	Oct-14-21

XFMRs

Recommended Infrared Reflow Temperature Profile for RoHS Compliant Parts

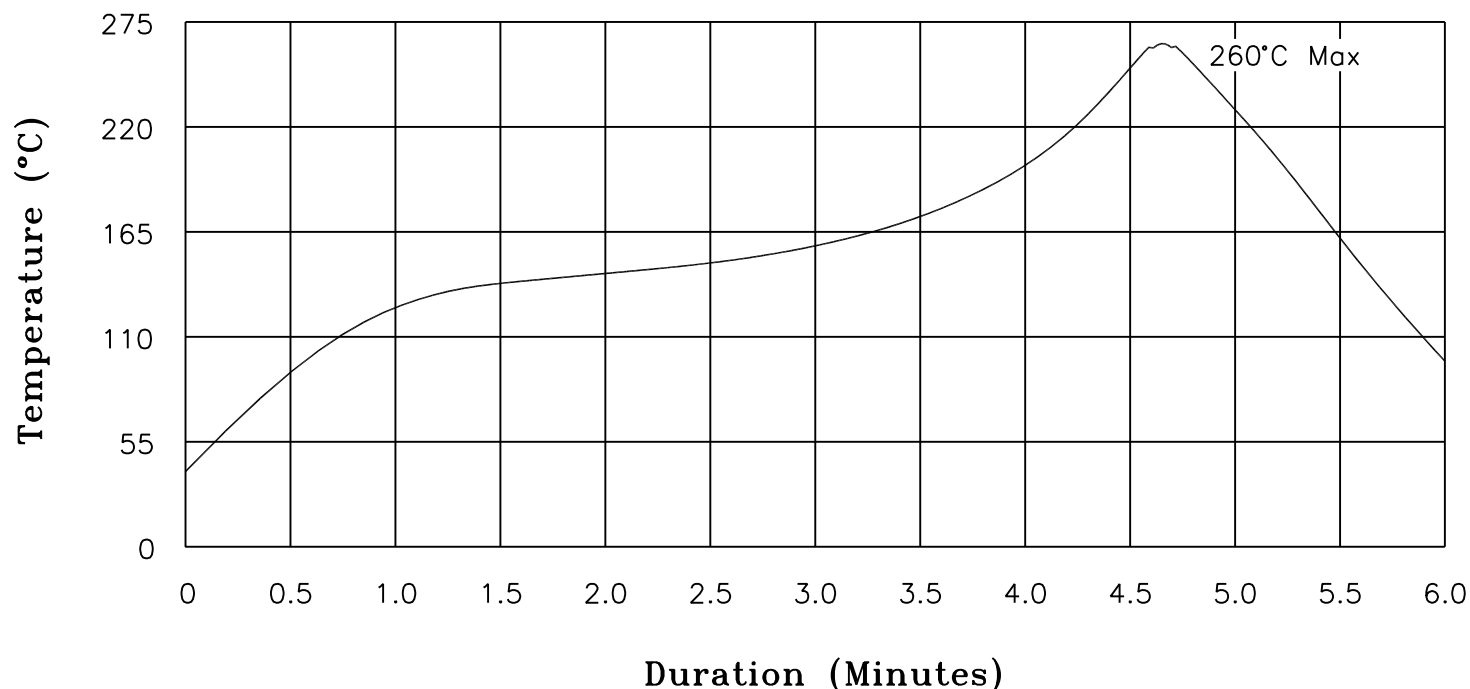

NOTES: Maximum duration at 260°+0/-5° with 10 seconds Max.
 Maximum duration above 217° shall be 60-150 seconds.
 ALL Temperatures refer to topside of the package, measured on the package body surface.

XFMRs Inc www.XFMRS.com	Title: IR REFLOW CHART (RoHS Compliant parts)		
	UNLESS OTHERWISE SPECIFIED TOLERANCES: N/A	P/N: N/A	REV. A
	DWN.	Juan Mao	Jan-16-05
	CHK.	YK Liao	Jan-16-05
SHEET 1 OF 1	APP.	MS	Jan-16-05

PROPRIETARY

Document is the property of XFMRs Group & is not allowed to be duplicated without authorization.

TAPE AND REEL SPECIFICATION:

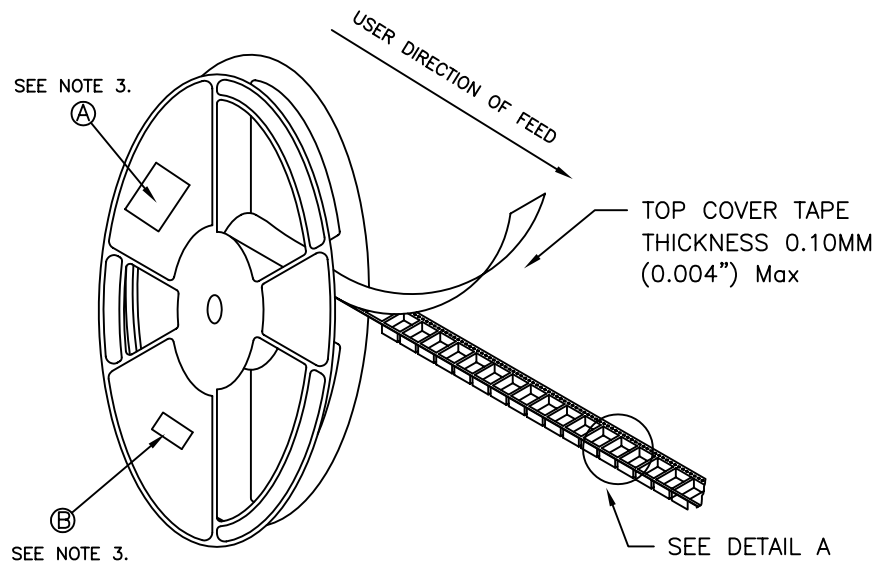

REEL AND TAPE ORIENTATION

13" REEL DIAMETER

NOTES:

- 1) PROCESS IN ACCORDANCE WITH EIA-481-2 STANDARDS
 - * TAPE LEADER DIMENSION 15.30" MIN.
 - * TAPE TRAILER DIMENSION 6.30" MIN.
- 2) PARTS SHOULD BE PACKAGED IN ACCORDANCE WITH ESD GUIDELINES IN EIA-541.
- 3) REEL LABEL: 'A' * PART NUMBER
 - * QUANTITY
 - * DATE CODE
- 4) 500pcs PER 13" REEL

DETAIL A

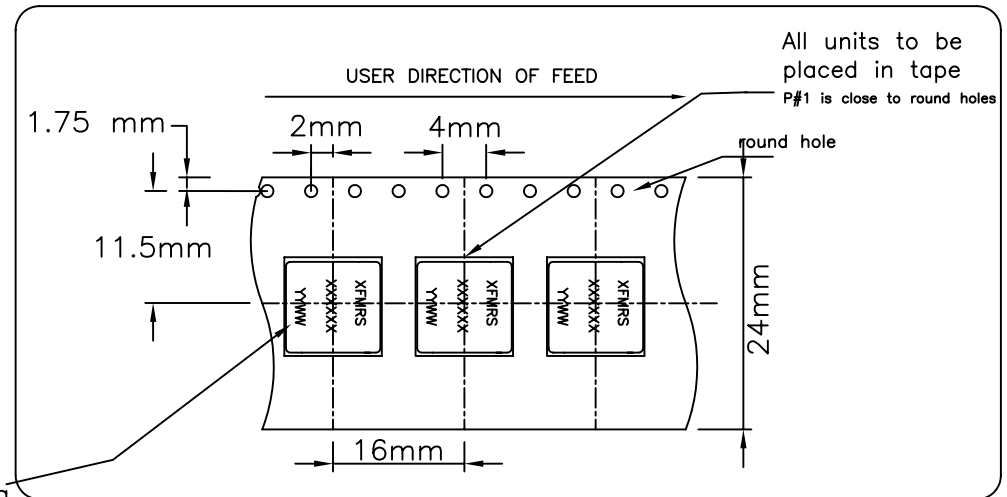

Details Marking
Refer to the
FG drawing

XFMRs Inc www.XFMRs.com	Title: T&R SPEC		
	UNLESS OTHERWISE SPECIFIED		P/N:XFHCL4LP Series
TOLERANCES: .xxs ±0.05 Dimensions in mm	DWN.	Kong	Jun-06-07
	CHK.	Kong	Jun-06-07
SHT 2 OF 2	APP.	MS	Jun-06-07

DOC REV: A/1

PROPRIETARY

Document is the property of XFMRs Group & is not allowed to be duplicated without authorization.