

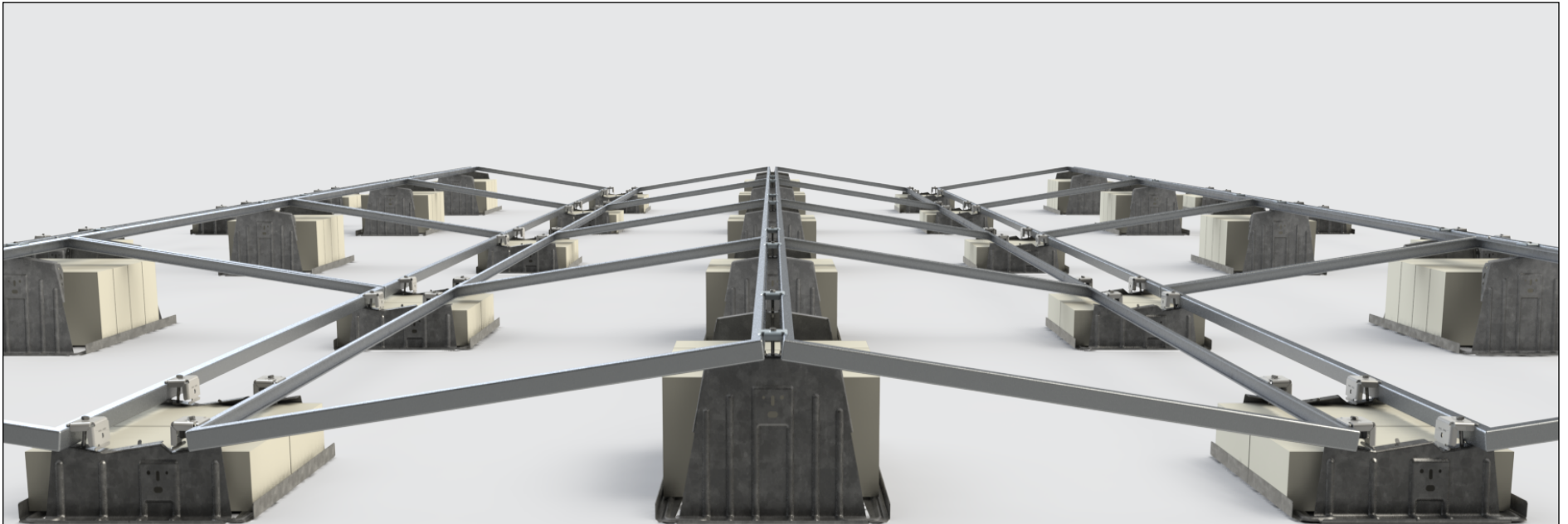

INSTALLATION GUIDE



UNIRAC Code-Compliant Installation Manual

© 2022 by Unirac, Inc. All rights reserved.



INSTALLATION GUIDE

TABLE OF CONTENTS

Tools & Specifications	1
System Components	2-3
Locate Array & Place Bays	4
Place Ballast	5
Module Placement & Attach Clamps	6
Attach Clamps	7
Module Installation & Wire Management.....	8
Ballast Bay Roof Attachment	9
Microinverter Installation & Wire Management.	10
Connect Grounding Lug.....	11
Electrical Diagram	12
Temporary Bonding Procedures	13
System Level Fire Code Compliance	14
Mechanical Load Testing.....	15
Compatible Modules	16-20

GENERAL NOTES:

If provided refer to construction drawings for project specific details.

Construction drawings have precedence over these installation guidelines.

TECHNICAL SPECIFICATIONS:

Material Types: 16G ASTM A653 GR50 Steel

Coating(s): G235 Galvanization, G180 Galvanization, G40 Galvanization + InterCoat® ChemGuard, G60 Galvanization + InterCoat® ChemGuard or G80 Galvanization + InterCoat® ChemGuard

Hardware: Stainless Steel

Bonding and Grounding: UL2703 Listed Continuous Bonding Path.

TOOLS REQUIRED OR RECOMMENDED FOR LAYOUT, ATTACHMENTS & INSTALLATION:

- Drill (Do Not Use An Impact Driver)
- 7/16" Socket
- Torque Wrench
- Tape Measure
- Chalk Reel
- Optional Spacers (See Diagram - Page Right)

GENERAL HARDWARE:

- ¼-20 X 2 ½" Hex Head Bolt - Module Clamps
- ¼-20 Stainless Steel U-Nuts

SAFETY:





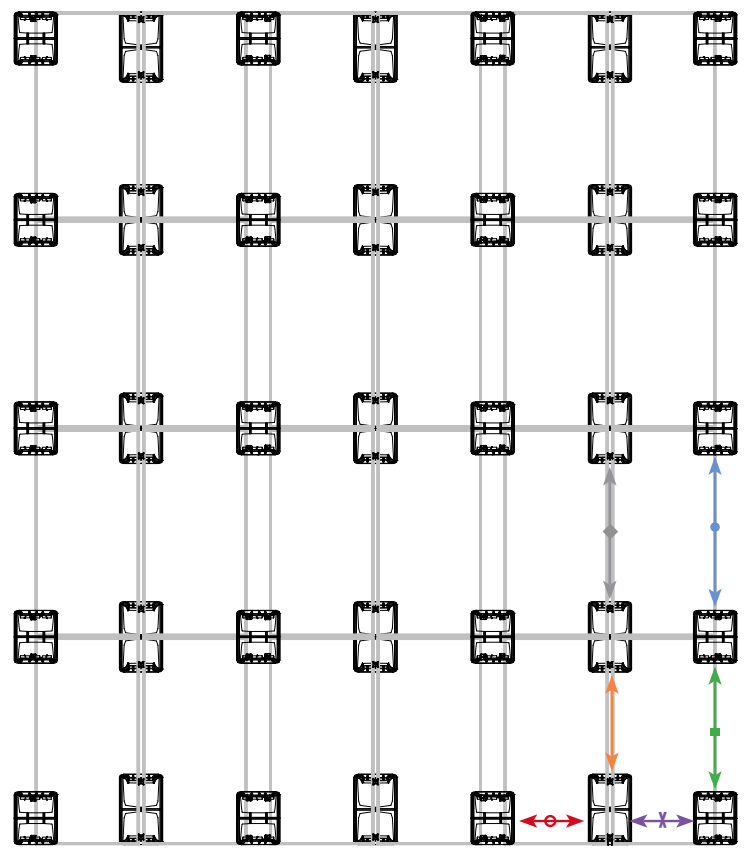

All applicable OSHA safety guidelines should be observed when working on a PV installation job site. The installation and handling of PV solar modules, electrical installation and PV racking systems involves handling components with potentially sharp metal edges. Rules regarding the use of gloves and other personal protective equipment should be observed.

LAYOUT ASSISTANCE TOOL:

Module Dimensions:	RMDT	Module location:	Spacing Equations (in Inches):
Module Length (ML) =	1	Valley N/S Column Spacing =	$ML+G-19.70"$
Module Width (MW) =	2	Edge Valley N/S Column Spacing =	$ML+G/2-29.55"$
Prefered module gap? (1/4" - 1" is permissible)	3	Edge E/W Row Spacing =	$(MW \times 0.990) - 15.69"$
	4	E/W Row Spacing =	$(MW \times 0.990) - 11.20"$
East/West Module Gap (G) =	5	Ridge N/S Column Spacing =	$ML+G-26.20"$
	6	Edge Ridge N/S Column Spacing =	$ML+G/2-39.30"$



SPACERS - OPTIONAL

- VALLEY COLUMN SPACING 
- EDGE VALLEY COLUMN SPACING 
- EDGE E/W ROW SPACING 
- E/W ROW SPACING 
- RIDGE N/S COLUMN SPACING 
- EDGE RIDGE N/S COLUMN SPACING 

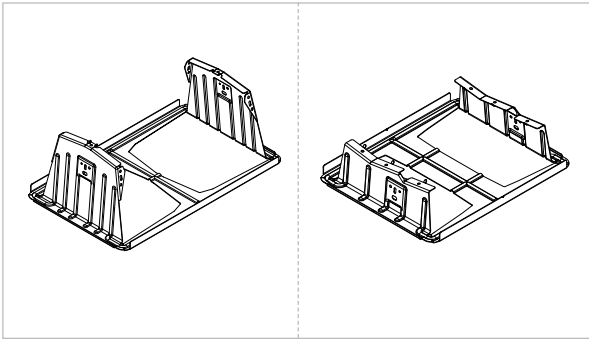

BALLAST BAY: The Ballast Bay is constructed of a high strength low alloy steel with a coating to protect against corrosion. This system has a modular design that allows for easy installation around roof obstructions and accommodates roof undulations. The Ballast Bays are designed to nest within each other to optimize shipping logistics. **NOTE: Systems installed on PVC roofs require ballast bays with pre-installed Santoprene pads.**

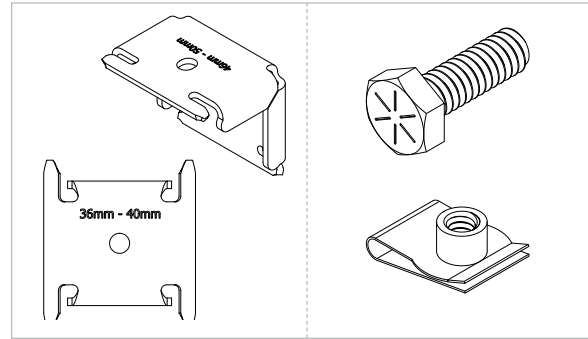

CLAMP & HARDWARE: The Module Clamp is made of Stainless Steel and can be used with module frame heights indicated on the clamp. The clamps are a portion of the UL2703 Listed system when installed according to this installation guide. A 1/4-20 stainless steel bolt and u-nut are the associated hardware for installing clamps.

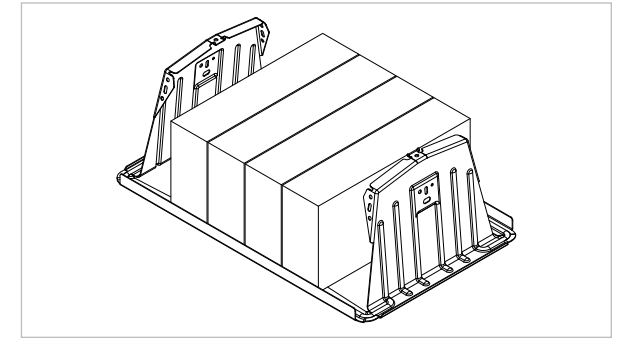

RIDGE BALLAST BLOCK: The Ridge ballast bay can fit up to 5 standard 4"x8"x16" solid concrete cap blocks. Block weight can range from 26 – 38 lbs and shall meet ASTM C1491 requirements for freeze thaw durability. Verify your block weights before using the Unirac U-builder online design tool

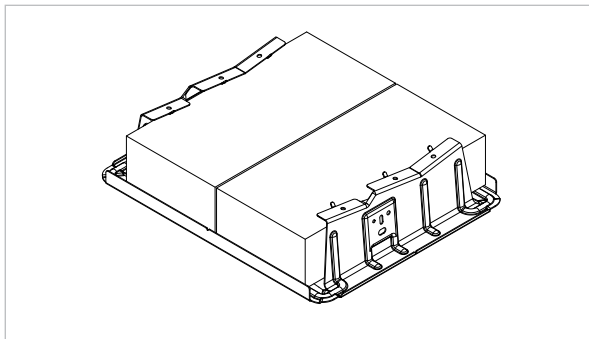

VALLEY BALLAST BLOCK: The Valley ballast bay can fit up to 2 standard 4"x8"x16" solid concrete cap blocks. Block weight can range from 26 – 38 lbs and shall meet ASTM C1491 requirements for freeze thaw durability. Verify your block weights before using the Unirac U-builder online design tool.

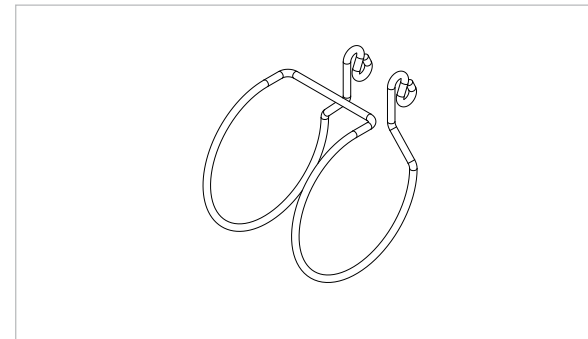

OPTIONAL WIRE MANAGEMENT: Custom Unirac wire clip along with mounting options for various off the shelf wire management clips.

NOTE: All conduit and wire ways should be grounded & bonded per the (NEC) National Electric Code.

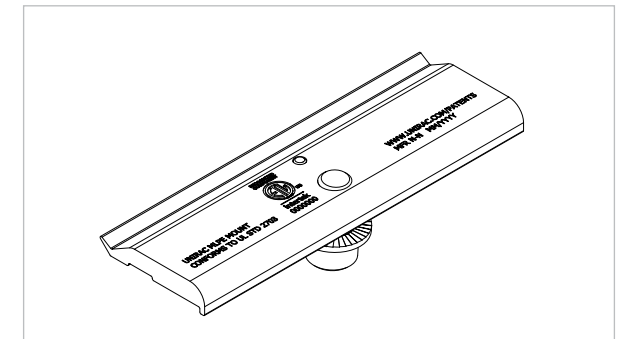

OPTIONAL MICROINVERTER MOUNTING: Microinverter / Power optimizer bracket, see page 10 for additional instructions.

PART NUMBER DATA

S.No.	Part Number	Part Description
1	310801	RMDT RIDGE BAY
2	310802	RMDT VALLEY BAY
3	310804	RMDT RIDGE BAY, PVC
4	310805	RMDT VALLEY BAY, PVC
5	310823	RMDT MIDCLAMP 46-50MM
6	310824	RMDT MIDCLAMP 41-45MM
7	310825	RMDT MIDCLAMP 36-40MM
8	310826	RMDT MIDCLAMP 30-35MM
9	310820	RM5/DT ENDCLAMP 30-40MM
10	310821	RM5/DT ENDCLAMP 41-45MM
11	310822	RM5/DT ENDCLAMP 46-50MM
12	310850	RM5/DT WIRE MGMT CLIP
13	310851	RM5 WD WIRE MGMT CLIP
14	310860	RM5/DT 1/4-20 CLIP U-NUT SS18-8
15	310882	RM5/DT H-ATTACHMENT KIT
16	008114M	MLPE MOUNT ASSY
17	205000S	ENPHASE ENGAGE CABLE CLIP
18	008002S	GROUND WEEBLUG #1
19	008009P	ILSCO LAY IN LUG (GBL4DBT)
20	310999	FLASHLOC RM KIT

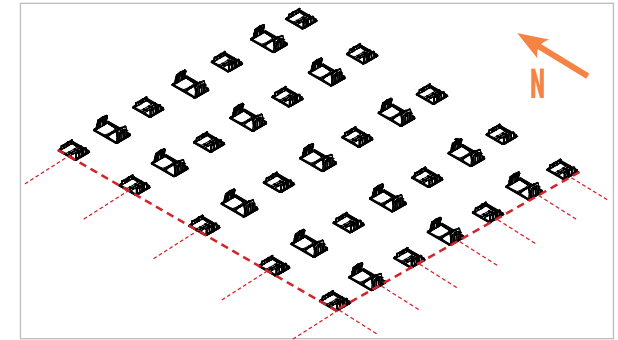
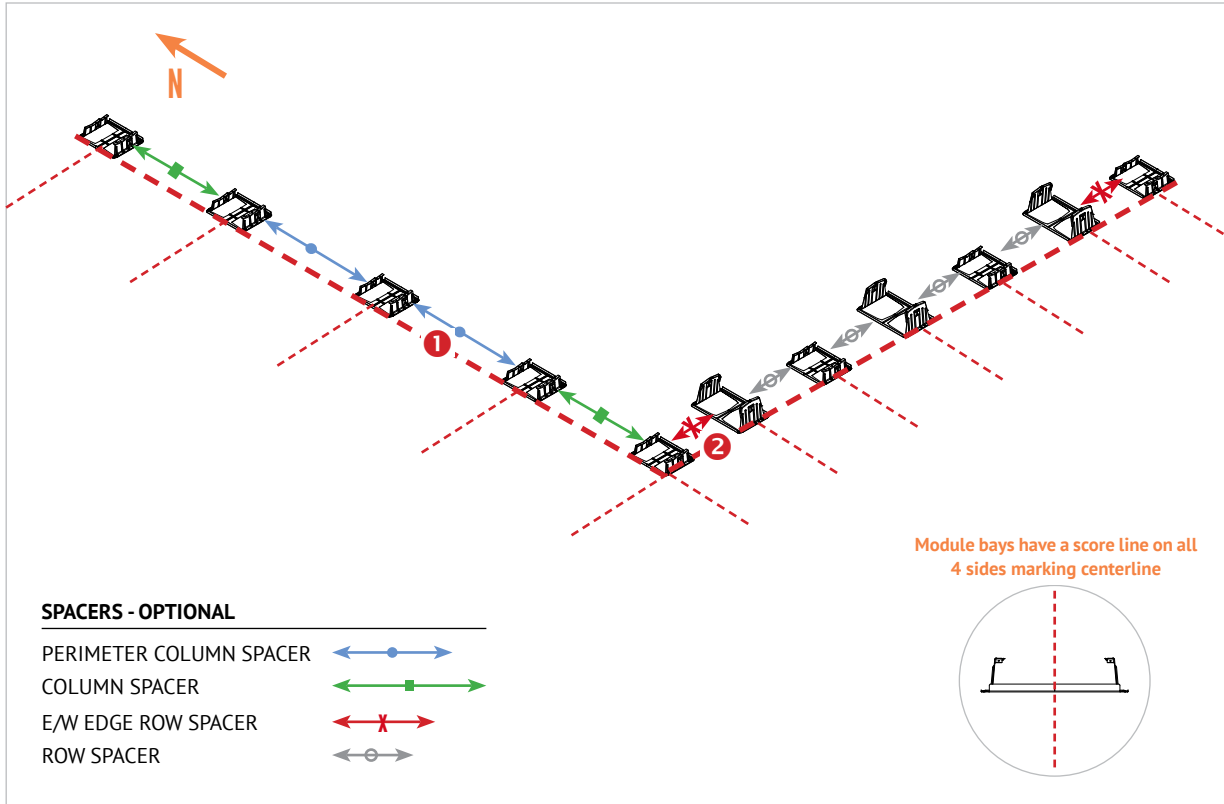

FILL IN BAYS

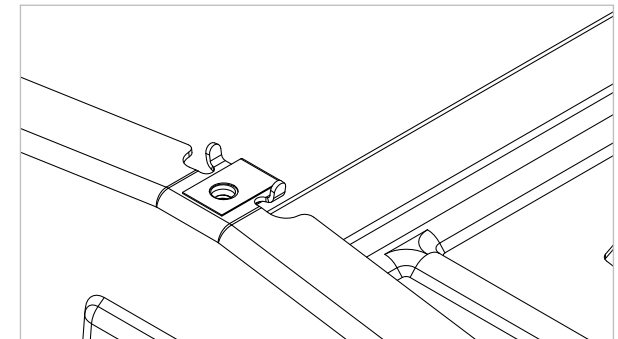

1 2 SNAP WEST PERIMETER CHALK LINE, THEN NORTH OR SOUTH PERIMETER CHALK LINE. As best practice, mark lines on perimeter chalk lines to locate center of bays

PLACE WEST PERIMETER BAYS FIRST, THEN NORTH OR SOUTH PERIMETER BAYS. If slip sheets are required, place per manufacturer recommendations.

NOTE: Custom spacers can be made to aid in the placement of bays on the roof. See page 1

INSTALL U-NUT It is recommended to install u-nuts prior to placing ballast blocks & modules on the bays.

NOTE: U-NUT - Single Use Only - Do not re-torque once fully seated

NOTE: If mechanical attachment is required, place prior to installation of modules.

PLACE ALL BALLAST: A maximum of 2 ballasts can be placed in valley bay, and up to 5 ballasts can be placed in the ridge. Site specific ballast calculations should be created for each individual project in accordance with the U-Builder design software. This system has been rated for the mechanical load provisions of UL2703. In addition, it has been designed and tested to comply with the more rigorous requirements of SEAOC PV1, PV2 and ASCE 7.

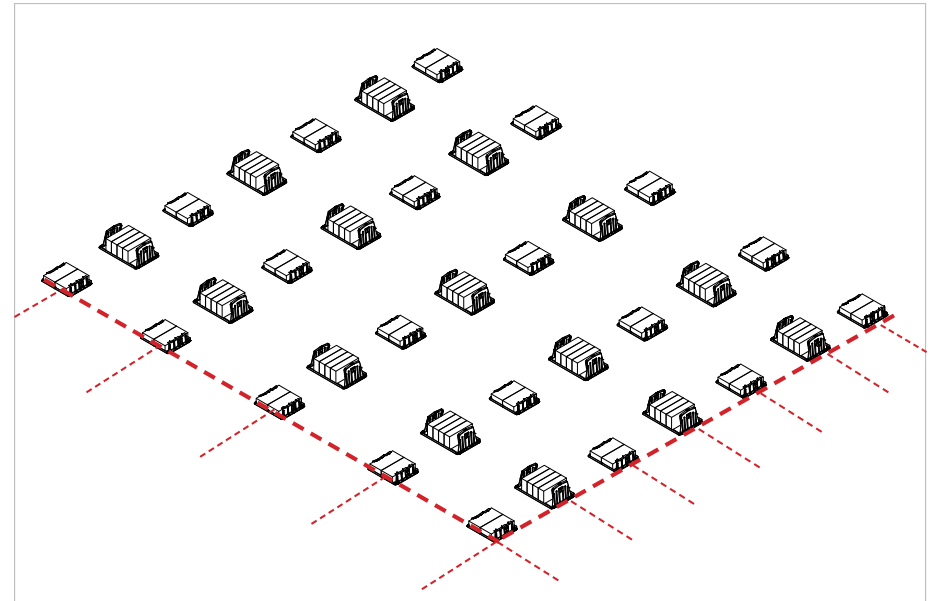

VALLEY BALLAST BLOCK OPTIONS:

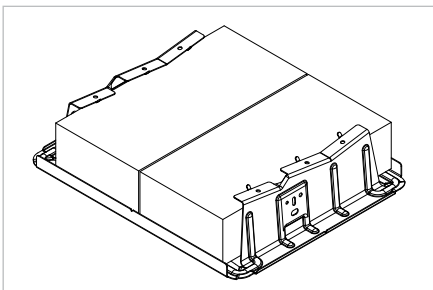
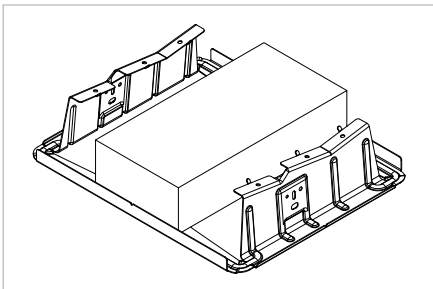

RIDGE BALLAST BLOCK OPTIONS:

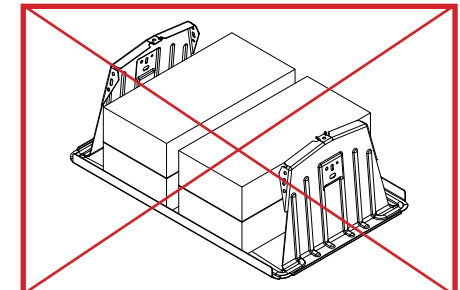
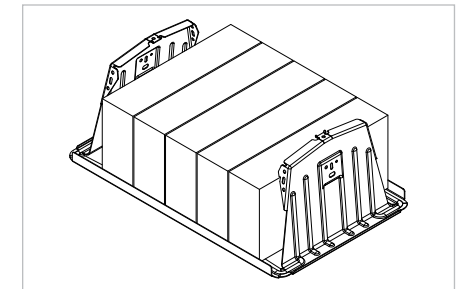
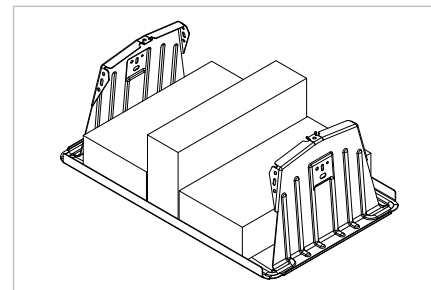
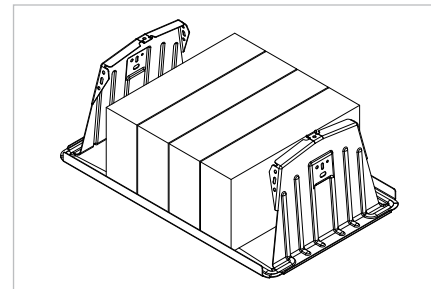
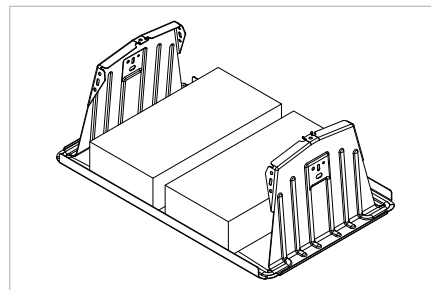
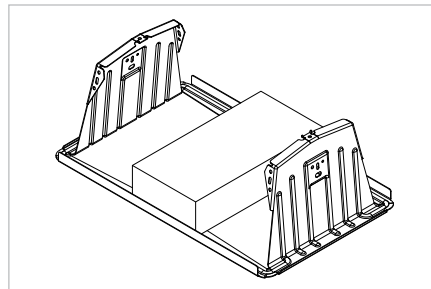

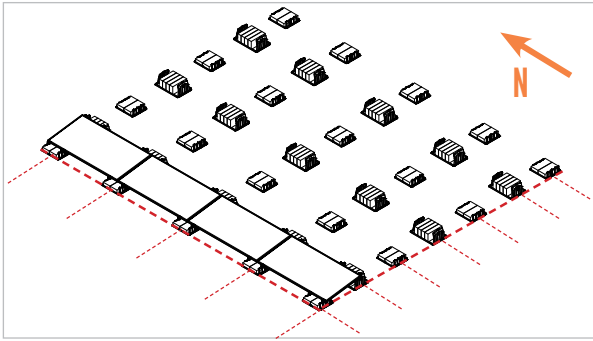

WESTERN EDGE MODULE PLACEMENT. Tabs on valley and ridge bay provide mechanical stop and aid in proper spacing at ridge. Rows of modules must be wired together at this time. See page 8 for wire management options.

NOTE: Modules may be placed on bays without immediate installation of clamps. Column Spacing: 1 inch maximum gap between modules / ¼ inch minimum gap between modules.

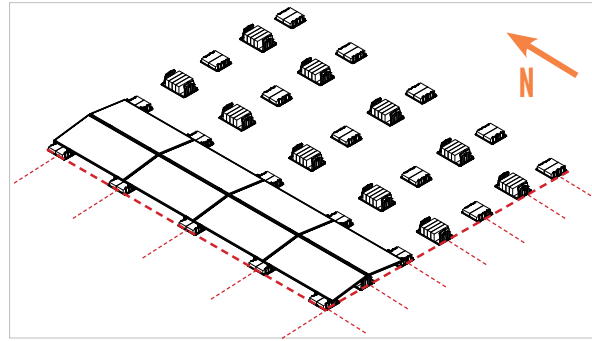

EAST OR WEST EDGE MODULE PLACEMENT. Rows of modules must be wired together at this time. See page 8 for wire management options.

NOTE: Clamps should be installed for each East/West pair of rows after wiring has been completed.

NOTE: Wiring, wire management, and electrical QC should be done as each row is built.

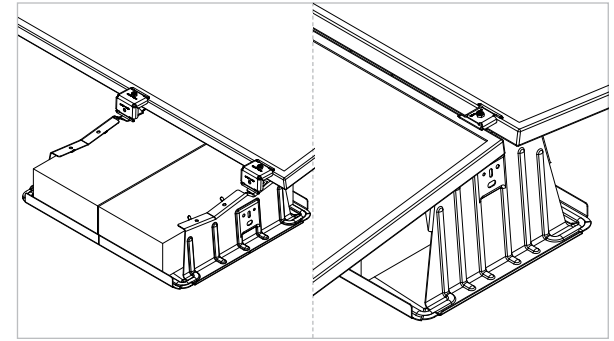

INSTALL CLAMPS

NOTE: U-NUT - Single Use Only - Do not re-torque once fully seated

NOTE: CLAMP AND BOLT - Single Use Only - Do not re-torque once fully seated

TORQUE VALUE: 7FT-LBS to achieve UL2703 required clamp load

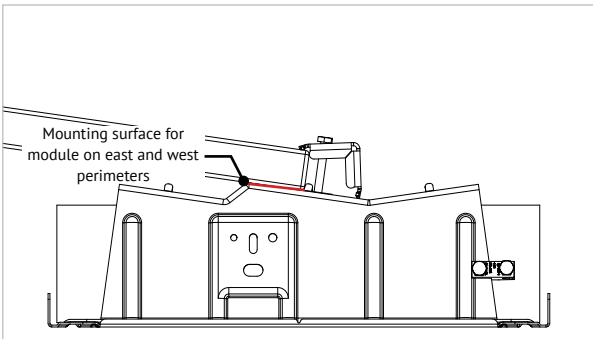

PROPER VALLEY BAY ORIENTATION AT EAST AND WEST PERIMETERS:

- Valley bays are designed to tuck up underneath the modules for east and west perimeters
- Bent tabs on all mounting surfaces act as a mechanical stop for the modules

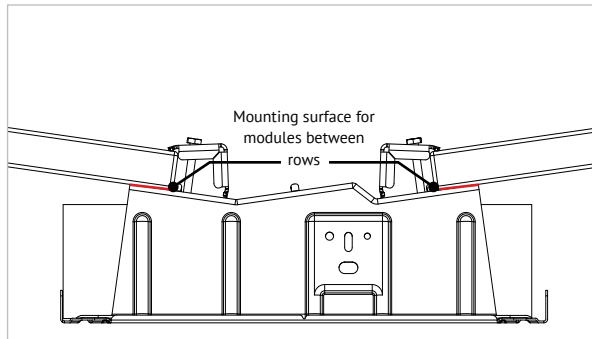

PROPER INTER-ROW SPACING:

- Inter row spacing at the valley is designed to provide an 8" space for walkways
- Bent tabs on all mounting surfaces act as a mechanical stop for the modules

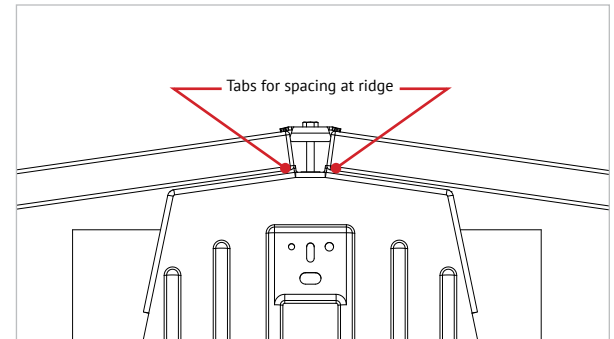

CLOSE UP MOUNTING AT RIDGE:

- Bent tabs on the mounting surfaces aid in setting the correct gap between modules at the ridge

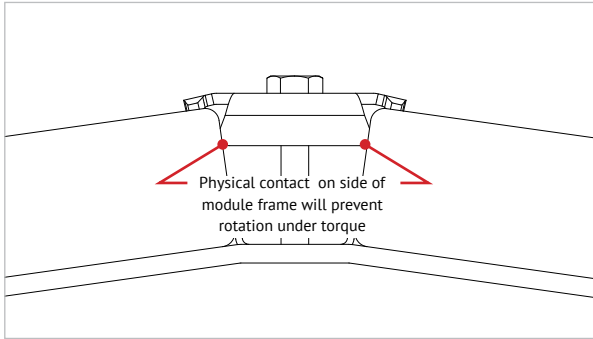

PROPER MID CLAMP INSTALLATION

- The top of the clamp is stamped for module frame height.
- Clamp should be firmly held against module frame while being torqued.

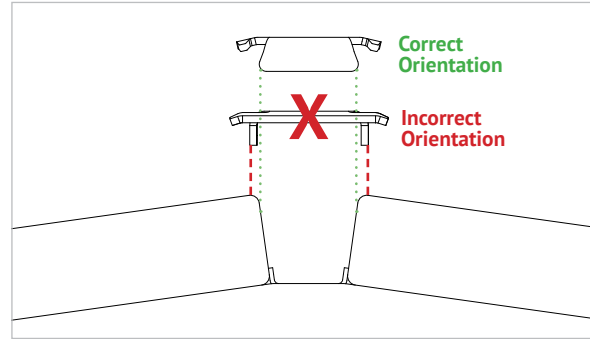

PROBLEM – CLAMP NOT ORIENTED CORRECTLY

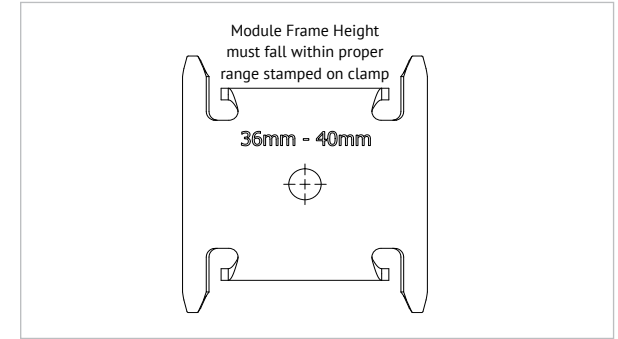

PROBLEM – NOT USING PROPER SIZE OF CLAMP FOR MODULE FRAME HEIGHT

- Double check the stamping on clamp to use the correct leg of clamp for module frame height
- The module height shall fall within the range shown on the top of the clamp

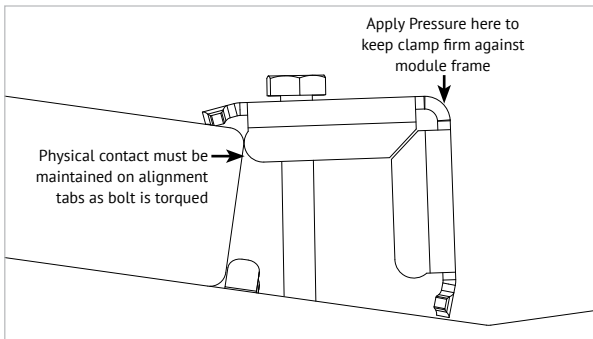

PROPER CLAMP INSTALLATION:

- Clamp is stamped for module frame height on each leg
- Clamp should be firmly held against module frame while being torqued

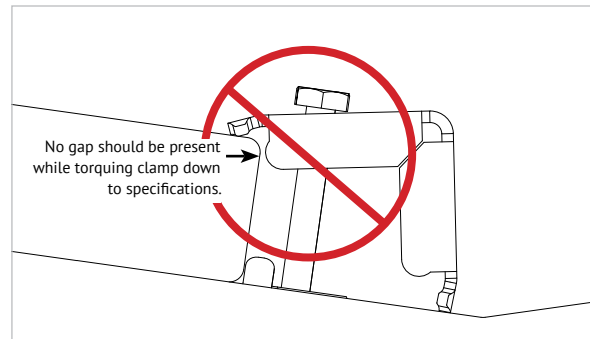

PROBLEM – CLAMP NOT SEATED AGAINST MODULE DURING TORQUING

- Clamp needs to be held securely against the module frame during torquing for proper installation

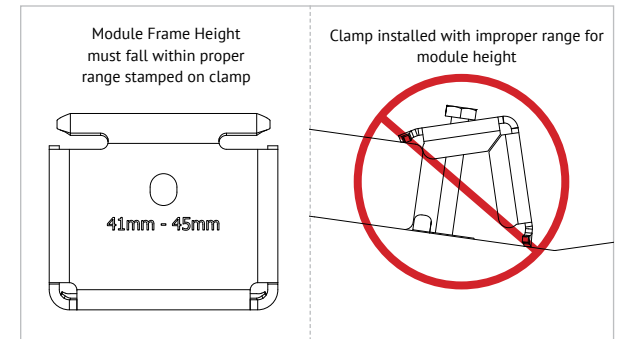

PROBLEM – NOT USING PROPER SIZE OF CLAMP FOR MODULE FRAME HEIGHT

- Double check the stamping on clamp to use the correct leg of clamp for module frame height
- The module height shall fall within the range shown on the top of the clamp
- Excessive angle on clamp will inhibit required clamp load on module

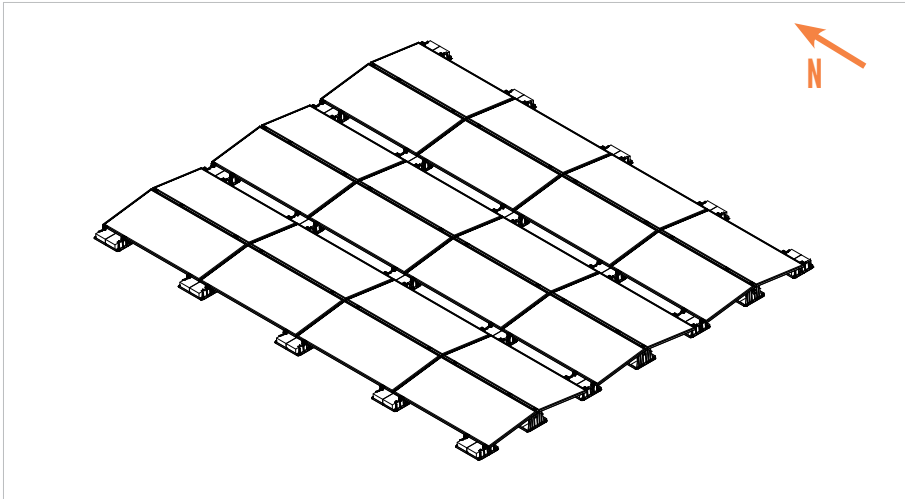

FILL IN ALL MODULES. Wire each row as modules are installed, and secure the modules in place after each east/west row pair is complete.

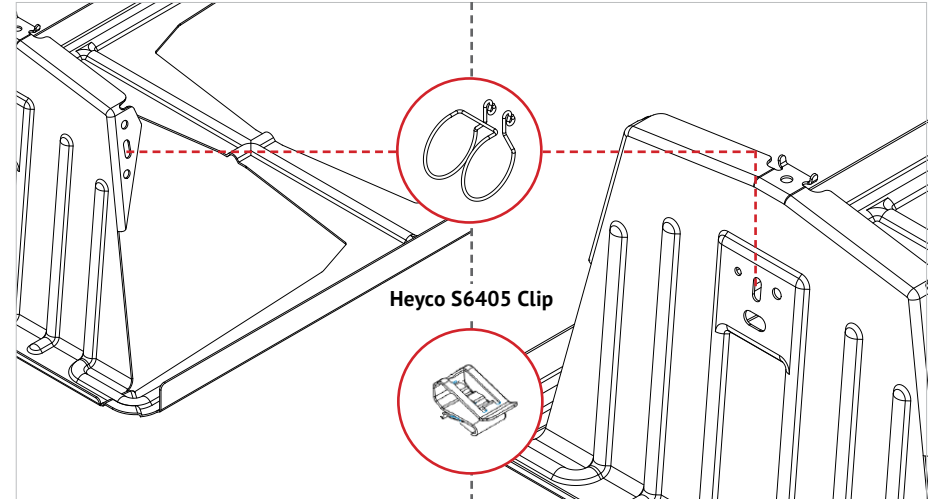

WIRE MANAGEMENT: Unirac provides a custom clip for wire management. Additional holes are included in the bay to accommodate other off the shelf wire management clips.

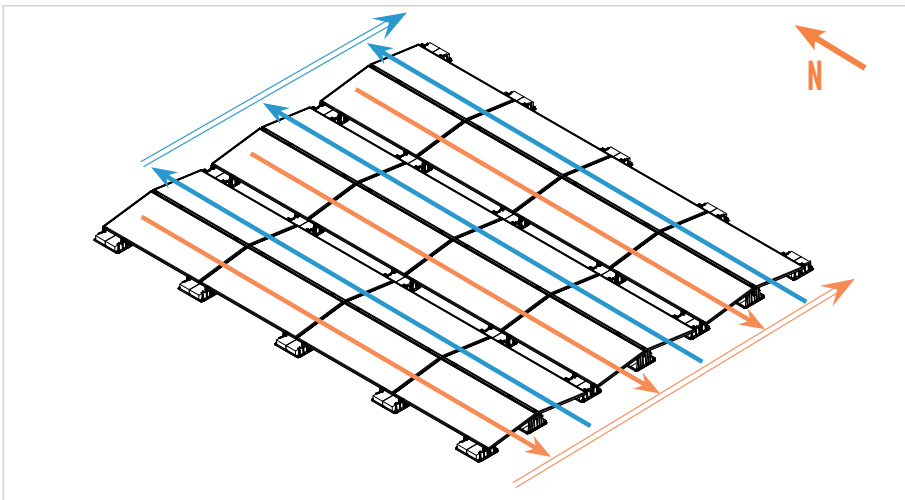

WIRE MANAGEMENT OPTION 1: Wire and bundle all east facing modules, run east facing bundle down north perimeter (or south perimeter) and vice versa for all west facing modules

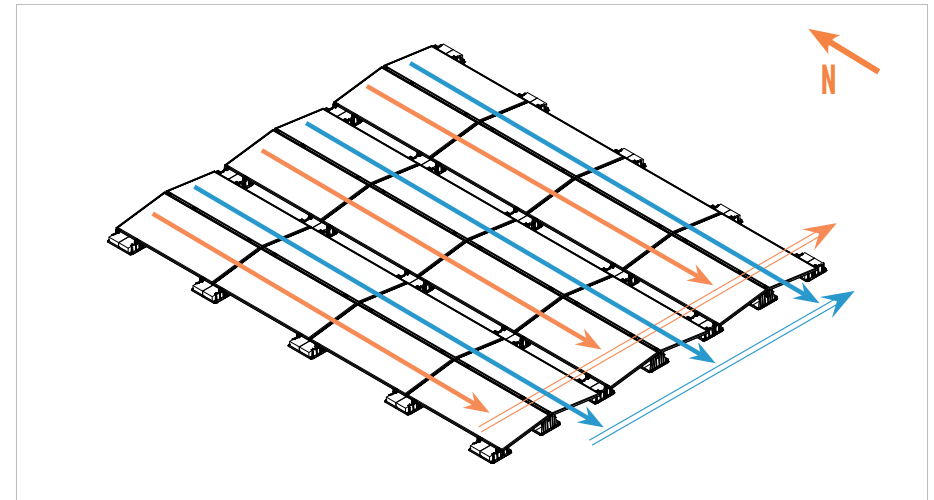

WIRE MANAGEMENT OPTION 2: Wire and bundle all east facing modules, wire and bundle all west facing modules. Run bundles along north or south perimeter

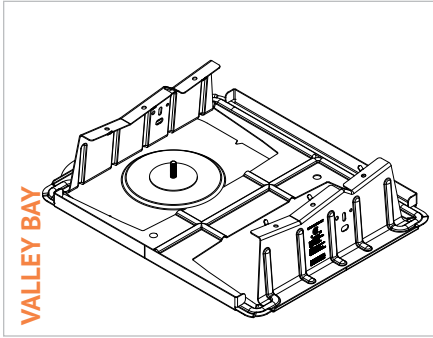

STEP 1 - POSITION U-ANCHOR: Position U-Anchor under bay requiring attachment and install according to manufacturer installation instructions.

NOTE: Position attachment so that it is close to center of the bay as possible.

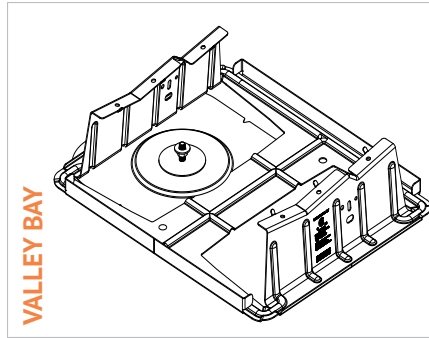

PLACE NUT AND WASHER: Include the nut and washer on the anchor stud prior to placing the stud through the strut.

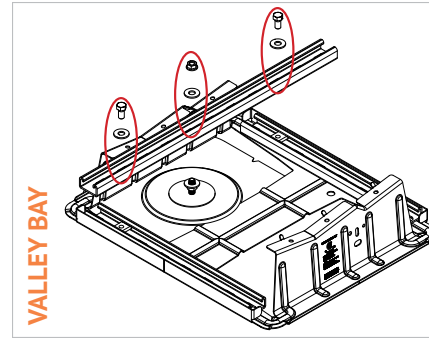

STEP - 3 PLACE H-STRUT: Position H-strut sections on bay as pictured above. Align the cross-strut with the anchor's stud. Connect side strut sections to cross strut using a strutnut, bolt, and washer as pictured.

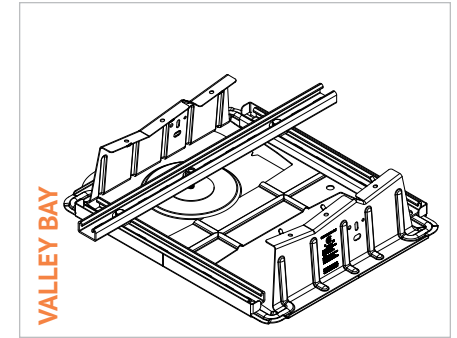

STEP 4 - SECURE H-STRUT TO U-ANCHOR: Place 3/8" washer and 3/8-16 serrated flange nut on anchor stud, serrations facing down and tighten to 30 ft-lb.

TORQUE VALUE: 30FT-LBS

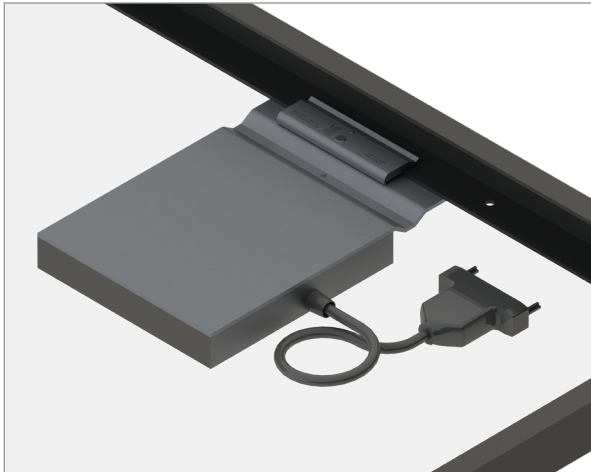

PRE-INSTALL MICROINVERTERS: Install MLPE in a location on the module that will not interfere with ballast bays or grounding lugs. To use trunk cable most efficiently, install MLPE components in the same locations on all modules in the same row.

TORQUE VALUE: 20FT-LBS



GROUNDING LUG MOUNTING DETAILS AS REQUIRED BY CODE & ENGINEER OF RECORD: The IlSCO lug has a green colored set screw for grounding indication purposes. One lug is recommended per continuous array, not to exceed 150ft X 150ft.

Unirac ROOFMOUNT is intended to be used with PV modules that have a system voltage less than or equal to that allowable by the National Electric Code (NEC). It is the installer's responsibility to check adherence to local codes.

NOTE: The installation must be conducted in accordance with the National Electric Code ANSI / NFPA 70.

Ground Lug	Bolt Size	Torque Value
IlSCO Lug SGB-4	1/4"-20	6.5 ft-lbs (75 in-lbs)
IlSCO Lug GBL-4	#10-32	2.9 ft-lbs (35 in-lbs)
Wiley 6.7	1/4"-20	10 ft-lbs (120 in-lbs)

NOTE: In order to prevent corrosion induced by dissimilar metals, it is important to verify that the bare copper wire does not come into contact with aluminum or galvanized steel. These materials must be kept separate.

Although conformance with UL2703 was demonstrated without the use of oxide inhibitor material, it is recommended by IlSCO to provide an optimized bonding solution for their lay-in lug.

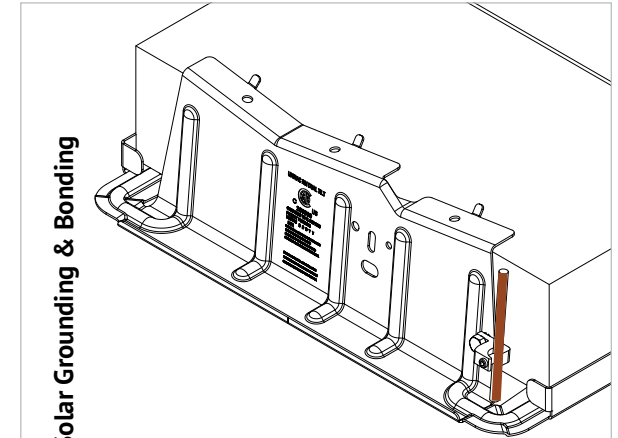

IlSCO GBL-4 Solar Grounding & Bonding

GROUNDING NOTE:
Can be installed on any location with a flat surface on the bay in order to ground the system.

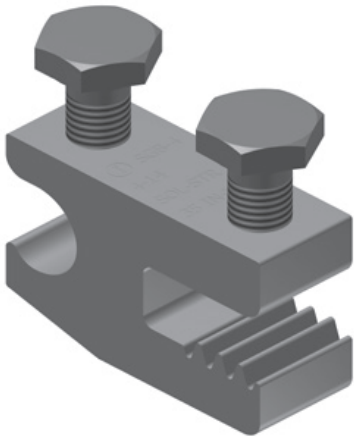

IlSCO SGB-4 Solar Grounding & Bonding

TERMINAL TORQUE:
Install conductor and torque to the following: 4-14 AWG: 35 in-lbs

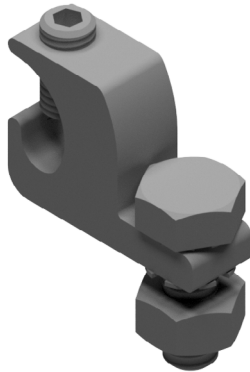

IlSCO GBL-4 Solar Grounding & Bonding

TERMINAL TORQUE:
Install Conductor and torque to the following:
4-6 AWG: 35 in-lbs, 8AWG: 25 in-lbs

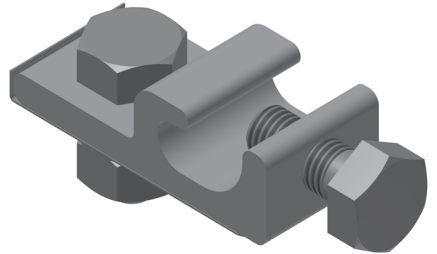

Wiley WEEB-Lug 6.7 Solar Grounding & Bonding



TERMINAL TORQUE:
Install Conductor and torque to the following:
4-6 AWG: 10 ft-lbs, 6-14 AWG: 7 ft-lbs

Note:

In order to avoid the need for utilizing bonding jumpers during maintenance or module removal do not attach the ground lug to a:

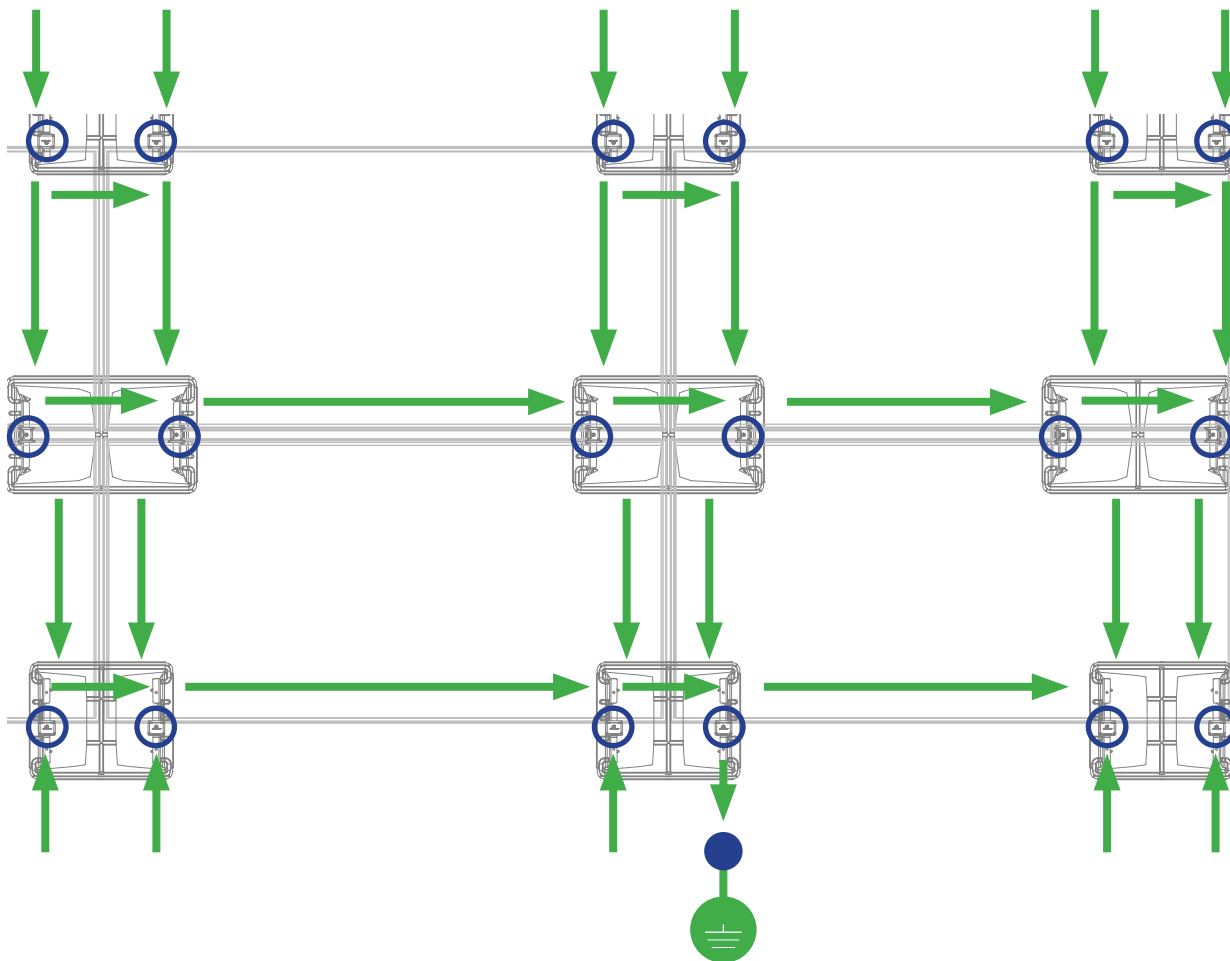
1. valley bay with less than two modules
2. ridge bay with less than three modules



-  Fault Current Ground Path
-  Ground Lug
-  Grounding Clip & Bolt
-  Min. 10 AWG Copper Wire

Module Frame
Module Bay w/ Grounding Clips

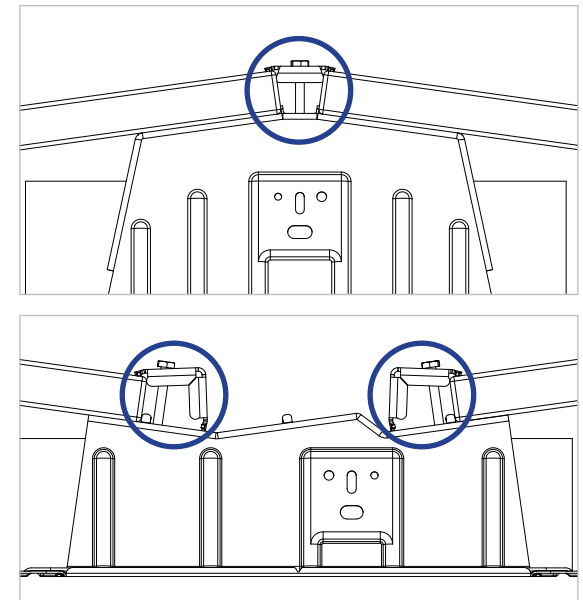

TEMPORARY GROUNDING & BONDING PROCEDURE: Periodic inspections should be conducted on the PV array to ensure there are not loose components, loose fasteners or corrosion. If any of the above items are found, the affected components are to be immediately replaced.

NOTE:

- If a module must be removed or replaced, a temporary bonding jumper must be used to ensure safety of the personnel and PV system.
- Removing a PV module from a system is not considered to be routine maintenance. This type of activity should only be performed by trained and qualified installers.
- In order to prevent corrosion induced by dissimilar metals, it is important to verify that the bare copper wire does not come into contact with aluminum or galvanized steel. These materials must be kept separate.

APPROVED LUGS and Terminal Torque see page 11

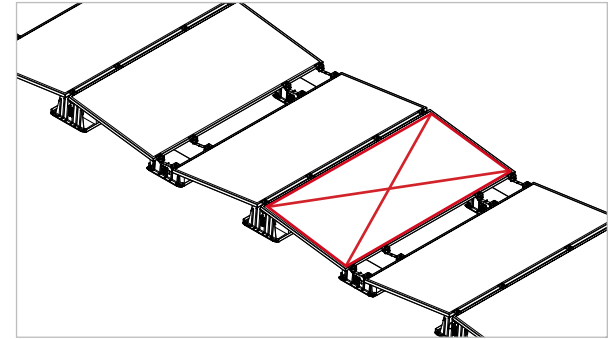

BONDING JUMPER REQUIRED: One example of a module removal that will require the use of a bonding jumper

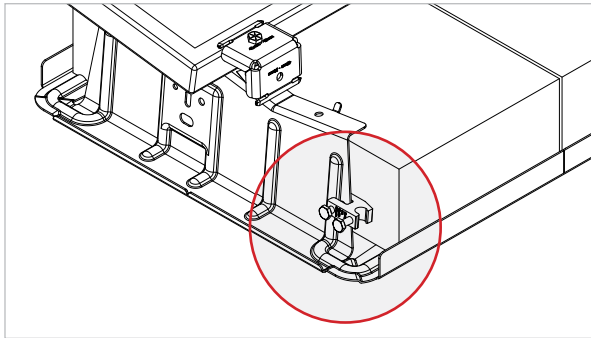

ATTACH LUGS: Use approved lug(s) to install on adjacent bays where the module is being removed.

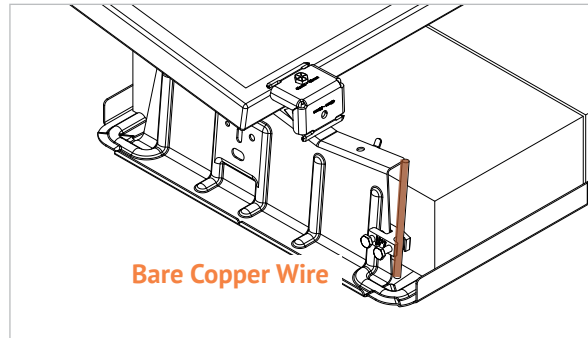

INSERT COPPER WIRE: Insert bare copper wire into each lug, providing a bonding jumper across the missing module location.

Remove module & reverse the operation after maintenance is complete

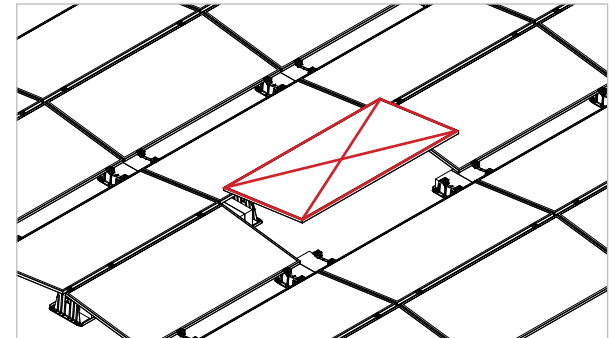

BONDING JUMPER NOT REQUIRED, due to integrated bonding/grounding path throughout module frames/bays around this location.

NOTE: CLAMP AND BOLT - Single Use Only - Use new clamps after any module replacements or system maintenance.

SYSTEM LEVEL FIRE CLASSIFICATION: The system fire class rating is only valid when the installation is conducted in accordance with the assembly instructions contained in this manual. RM ROOFMOUNT has been classified to the system level fire portion of UL2703. It has achieved Class A performance for low sloped roofs when used in conjunction with type 1, 2, 29 and 30 module constructions. Please see the specific conditions below for mounting details required to maintain the Class A fire rating. Minimum and maximum roof slopes are restricted through the system design and layout rules. The fire classification rating is only valid on roof pitches less than 2:12 (slopes < 2 inches per foot, or 9.5 degrees).

NOTE: Type 1, 2, 29, and 30 information is generally located on back of modules or through manufacturers documentation. Some building codes and fire codes require minimum clearances around such installations, and the installer should check local building code requirements for compliance.

Module Type	System level Fire Rating	Mitigation
Type 1	Class A	None Required / No Limitations
Type 2	Class A	None Required / No Limitations
Type 29	Class A	None Required / No Limitations
Type 30	Class A	None Required / No Limitations

TYPE 1, 2, 29, and 30 CLASS A FIRE RATING MOUNTING ORIENTATION

Unirac RM Dual tilt has achieved Class A system level fire performance for type 1 and type 2 module constructions. There are no provisions necessary in order to meet Class A requirements for this product.

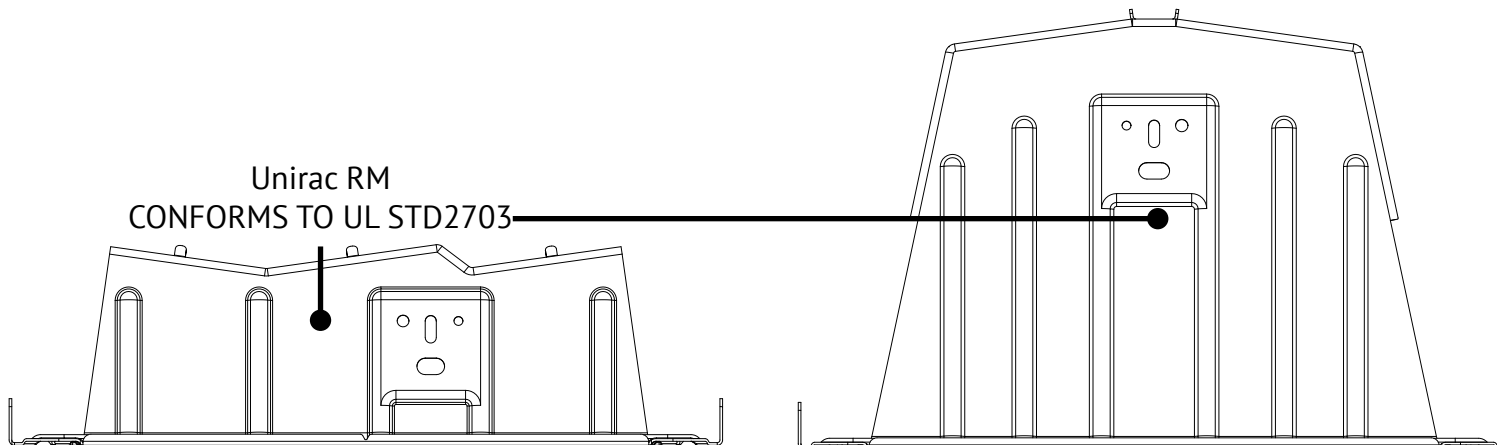

MECHANICAL LOAD TEST

The Unirac RM system has been tested to the mechanical load provisions of UL2703 and covers the following basic parameter(s):

- Test Loads = 1.5 x Design Loads
- PV modules may have a reduced load rating, independent of the RM5 load rating. Please consult the PV module manufacturer's installation guide for more information.

TESTED MODULES

Module Manufacturer	Model / Series	Area (sq ft)	Standard Installation Configuration - No Mid Bay		Installed with Additional Bay at Modules North/South Center	
			Up Design Load (psf)	Down Design Load (psf)	Up Design Load (psf)	Down Design Load (psf)
Jinko	JKMxxxM-72HL4-V	27.8	17.24	36.20	Not Tested	Not Tested
Canadian Solar	CS7N-xxxMB-AG	33.4	15.67	14.85	23.52	33.33

NOTE:

All installation configurations have achieved a minimum of 5psf design load in the downslope direction.

ELECTRICAL BONDING & GROUNDING TEST MODULES: This racking system may be used to ground and/or mount a PV module complying with UL1703 or UL61730 only when the specific module has been evaluated for grounding and/or mounting in compliance with the included instructions.

Manufacture	Module Model / Series	Manufacture	Module Model / Series	Manufacture	Module Model / Series
Aionrise	AION60G1, AION72G1	Boviet Solar(Cont.)	BVM6612M-XXXS-H-HC-BF-DG BVM7612M-H-HC-BF-DG	CertainTeed	CTxxxMxx-(01/02/03/04) CTM10400HC11-06 CTM10400HC11-08 CTM10400HC11-09 CTTxxxHC12-08 CTxxxHC11-06 CTxxxPxx-01
Aleo	P18 & P19 S18, S19, S59, & S79	BYD	P6K Series, MHK		Eco Solargy
Aptos Solar	DNA-108-(MF/BF)10-xxxW DNA-120-(MF/BF)10-xxxW DNA-120-(MF/BF)26 DNA-120-MF10 DNA-144-(MF/BF)26 DNA-144-BF10-xxxW-DG	Canadian Solar	CS1(K/H/U/Y)-MS CS3(U/K)-MB-AG CS3K-(MB/MS/P/PB) CS3L-(P/MS) CS3N-MS CS3U-(MB/MS/P/PB/PB-AG) CS3W-(MB-AG/MS/P/P-PB-AG) CS3Y-MB-AG CS5A-M CS6.1-60TM-H CS6.1-72TB-H CS6.2-66TB-xxxH CS6K-(M/MS/P) CS6P-(M/P) CS6R-MS CS6R-xxxMS-HL CS6U-(M/P) CS6V-M CS6W-(MB-AG/MS) CS6W-xxx-TB-AG CS6X-P, CS7L-MB-AG CS6.1-54TM-H CS7L-MB-AG CS7L-TB-AG CS7L-xxxMB-AG CS7N-xxxMB-AG CS7N-xxx MS CS7N-xxxTB-AG ELPS CS6(P/A)-MM	EMMVEE	ExxxHCBT144-T Titanium Clear
	Astronergy		ASM6612P Series CHSM6610(P/M)/HV CHSM6612(P/M)/HV CHSM72(P/M)-HC CHSM72M(DG)/F-BH	Energy America	ZLK-xxx
AU Optronics	PM Series		ET Solar	ETAC & ET Modules ET-M672BHxxxTW ET-M772BH520-550WW/WB ET-M772BHxxxTW/TB	
Auxin	AXN10Mxxx AXN6M610T AXN6M612T AXN6P610T AXN6P612T AXNG1M SERIES		Flextronics	FXS	
	AC-xxx(M/P)/(60/72)(S/V) AC-xxxP/156-60S AC-xxxTGB/144TS AXIblackpremium X HC: AC-xxxMH/(120/144)(SB/VB) AXIblackpremium XL HC: AC-xxxMH/120(SB/VB) AXIpremium X HC: AC-xxxMH/(120/144)(S/V) AXIpremium XL HC: AC-xxxMH/120(S/V)		Freedom Forever	FF-MP-BBB-xxx FF-MP1-BBB-xxx	
Bluesun Solar	BSMxxxM10-72HBD		FreeVolt	PVGraf	
Boviet Solar	BVM6610 BVM6610M-xxxS-H-HC BVM6610M-xxxS-H-HC-BF BVM6612		GCL	GCL-P6 & GCL-M6 Series	
			Centrosolar America	C-Series E-Series	
			Hansol	TD-AN3, TD-AN4, UD-AN1 & UB-AN1	
			Hanwha SolarOne	HSL 60 & HSL 72	
		Heliene	36M, 60M, 60P, 72M & 72P Series 132HC M10 SL Monofacial Module 144HC M10 SL Bifacial 144HC M6 156HC M10 SL Bifacial		
		HT-SAAE	HT72-156(M/P), HT72-156P-C, HT72-156P(V)-C HT60-156M-C, HT60-156M(V)-C, HT72-166M HT72-18X		

- Unless otherwise noted, all modules listed above include all wattages and specific models within that series. Variable wattages are represented as "xxx"
- Items in parenthesis are those that may or may not be present in a compatible module's model ID
- Slashes "/" between one or more items indicates that either of those items may be the one that is present in a module's model ID

ELECTRICAL BONDING & GROUNDING TEST MODULES: This racking system may be used to ground and/or mount a PV module complying with UL1703 or UL61730 only when the specific module has been evaluated for grounding and/or mounting in compliance with the included instructions.

Manufacture	Module Model / Series
Hyperion Solar	HY-DH108P8(B) HY-DH108N8B HY-DH144P8 HY-DH156N8 HY-DH156P8
Hyundai	HiN-SxxxXG(BK) HiN-TxxxNF(BK) HiN-TxxxNI HiN-TxxxNJ HiN-TxxxOJ HiS-SxxxOJ HiS-SxxxXG(BK) HiS-SxxxYH(BK) HiS-TxxxNJ
Hyundai Heavy Industries	MG, TG, RG, KG, MI, RI, KI, HI & TI Series HiA-SxxxHG, HiD-SxxxRG(BK), HiS-S400PI
Illuminate USA	IL5-72HBD-xxx M IL8-66HGD-xxx M
Imperial Star	ISM7-SHDD108-400/M
Inception	mSolar 108BB HC Series (TXI10-xxx108BB) mSolar 144BB HC Series (TXS6-xxx144BB)
ITEK	iT, iT-HE & iT-SE Series
Japan Solar	JPS-60 & JPS-72 Series
JA Solar	JAM54S30 xxx/MR JAM54S31 xxx/MR JAM66D45 LB JAM72D10 xxx/MB JAM72D30MB JAM78D10MB JAM72S30 /MR JAM72D40 xxx/MB JAM72S30 /MR JAP6-60, JAM6-60 JAP6-72, JAM6-72

Manufacture	Module Model / Series
JA Solar	JAP6(k)-60-xxx/4BB, JAP60S##-xxx/** JAM6(k)-60-xxx/**, JAM60S##-xxx/** JAP6(k)-72-xxx/4BB, JAP72S##-xxx/** JAM6(k)-72-xxx/**, JAM72S##-xxx/** i. ##: 01, 02, 03, 09, 10 ii. **: SC, PR, BP, HiT, IB, MW, MR ** = Backsheet, ## Cell technology
Jinko	JKMxxx(P/PP)-60, JKMxxxPP-60(Plus) JKMxxxPP-60B, JKMxxxM-60 JKMxxxM-60(B/L/HL/BL/LV) JKMxxxM-60-V, JKMxxxPP-60B-J4 JKMSxxxM-60 JK07(A/B) JKMSxxx(P/PP)-60, JKMSxxxPP-60B-J4 JKMxxx(M/P/PP)-72, JKMxxx-72L-V JKMxxxM-72L-V, JKMxxxM-72HL(4)-V JKMxxxM-72HLM-TV JKMxxx(M/P/PP)-72-V, JKMxxxPP-72(Plus) JKMxxx(P/PP)-72B JKMSxxx-72, JKMSxxx(P/PP)-72 JKMxxxM-7RL3-V, JKMxxxM-72HBL-V JKMxxxM-72HL4-TV JKMxxxM-6RL3-B JKMxxxN-72HL4-BDV JKMxxxN-54HL4-B JKMxxxN-72HL4-TV JKMxxxM-7RL3-TV JKMxxxN-72HL4-BDX
Kyocera	KD-F Series
LA Solar	BLA Model LSxxxBF LSxxxBL LSxxxBL (410 watt) LSxxxHC LSxxxHC (430-450 watt range)

Manufacture	Module Model / Series
LG Electronics	LGxxx(E1C/E1K/N1C/N1K/N2T/N2W/S1C/S2W/Q1C/Q1K)-A5 LGxxx(A1C/M1C/M1K/N1C/N1K/Q1C/Q1K/QAC/QAK)-A6 LGxxxN2T-B5, LGxxxN1K-B6 LGxxx(N1C/N1K/N2T/N2W)-E6 LGxxxN2T-J5 LGxxx(N1K/N1W/N2T/N2W)-L5 LGxxx(M1C/N1C/Q1C/Q1K)-N5 LGxxx(N1C/N1K/N2W/Q1C/Q1K)-V5 LGxxxN3K-V6
LONGi	LR4-60(HPB/HIB/HPH/HIH) LR4-72(HPH/HIH), LR5-54-HPB-xxxM LR4-72HBD xxxM LR5-54HABB-xxx M (fire type 29 only) LR5-54HPB-xxx M LR5-54-HPB-xxxM LR5-54HTB xxxM LR5-72HBD xxx M LR6-60, LR6-60(BK/PE/PB/PH/HPB/HIB/HPH/HIH) LR6-72, LR6-72(BK/HV/PE/PB/PH/HPH/HIH) LR7-72HGD-xxx M LR8-54HGBB LR8-66HGD-xxx M
Maxeon	SPR-MAX3-xxx-COM SPR-MAX3-XXX-R SPR-MAX3-XXX-BLK-R SPR-MAX6-xxx SPR-MAX6-xxx-BLK
Meyer Burger	Meyer Burger Black Meyer Burger White Meyer Burger Glass

- Unless otherwise noted, all modules listed above include all wattages and specific models within that series. Variable wattages are represented as "xxx"
- Items in parenthesis are those that may or may not be present in a compatible module's model ID
- Slashes "/" between one or more items indicates that either of those items may be the one that is present in a module's model ID

ELECTRICAL BONDING & GROUNDING TEST MODULES: This racking system may be used to ground and/or mount a PV module complying with UL1703 or UL61730 only when the specific module has been evaluated for grounding and/or mounting in compliance with the included instructions.

Manufacture	Module Model / Series	Manufacture	Module Model / Series	Manufacture	Module Model / Series
Mission Solar Energy	MSE MONO	Philadelphia Solar	PS-M108(HCBF)-400W (30 & 35mm frames)	Q Cells (cont.)	Q.PEAK DUO BLK ML-G10.a+
	MSE PERC		PS-M144(HCBF)-xxxW		QPEAK DUO G10.C1+ AC
	MSExxx(SR8T/SR8K/SR9S/SX5T/SX5K/SX6W)		PS-MNB108(HCBF)-xxxW		Q.PEAK DUO ML-G12S.d / BFG
	MSExxxHT0B	PS-MNB144(HCBF)-xxxW	Q.PEAK DUO XL-(G10/G10.2/G10.3/G10.c/G10.d)		
	MSExxxSX6Z	PS-MNB156(HCBF)-xxxW	Q.PEAK DUO XL-G10.3/BFG		
	MSExxxSX9R	Phono Solar	PSxxxM4(H)-24/TH		Q.PEAK DUO XL-(G11.2/G11.3)
	MSH10-xxxHN4G		Phono Solar Tech.		Standard Modules
	MSH10-xxxHT4T	Prism Solar			P72 Series
	MSI10-xxxHN4G		P72X-xxx		Q.PEAK DUO XL-G11.3/BFG
	MSI10-xxxHT4G		Q Cells		B.LINE (PLUS/PRO) BFR G4.1
MSI10-xxxHT4T	B.LINE PEAK DUO (G7/G7.2)	Q.PLUS/PEAK/PRO - L G4.x			
MSN10xxxHT4T	B.LINE PEAK DUO L-(G5/G5.1/G5.2/G5.3)	Q. PLUS/PRO G3, Q.PLUS BFR G3.1, Q.PRO/PLUS G4			
MSX10-xxxHN0B	B.LINE PEAK DUO L-(G7/G7.1/G7.2/G7.3)	Q.PRO BFR G4x, Q.PEAK (BLK) G4.1 (TAA/MAX)			
Mitrex	Mxxx-L3H	B.LINE PLUS/PRO - L G4.x		Q.PRO EC-G4.4	
	Mxxx-I3H	Q.PEAK DUO (BLK) G5		Q.PRO L-G2, Q.PEAK (BLK) (G3/G3.1)	
Mitsubishi	MJE & MLE Series	Q.PEAK DUO (BLK)-G6+		Q.TRON BLK M-G2+	
		Q.PEAK DUO (BLK)-G7		Q.TRON BLK M-G2+ AC	
mSolar	TXI10-xxx108BB	Q.PEAK DUO (BLK) G8(+)		Q.TRON BLK M-G2.C+	
Neo Solar Power Co.	D6M Series	Q.PEAK DUO (BLK) ML-G10(.a)(+)		Q.TRON BLK M-G2.F+	
		Q.PEAK DUO (BLK) ML G9(+)	Q.TRON BLK M-G2.F1+/AC		
NE Solar	NESE xxx-60MH-M6	Q.PEAK DUO (G7/G7.2)	Q.TRON BLK M-G2.H+		
	NESE xxx 66MHB-G12	Q.PEAK DUO BLK-G10(+)	Q.TRON BLK M-G2.H1+/AC		
	NESE xxx-72MHB-M10	Q.PEAK DUO BLK G10+ /AC	Q.TRON BLK M-G2+ SERIES		
	NESE xxx 72MHT-M10	Q.PEAK DUO BLK-G6+/TS	Q.TRON M-G2+ SERIES		
	NESE xxx 72THB-M10	Q.PEAK DUO BLK ML-G10.B+	Q.TRON XL-G2.3 / BFG		
	NESE xxx 72MHB-M10	Q.PEAK DUO BLK ML-G10+ / t	Q.TRON XL-G2.3 / BFG		
Panasonic	VBHNxxxSA(15/16)	Q.PEAK DUO BLK ML-G10+ / TS	Q.PEAK DUO BLK ML-G10.XY+/AC (where "X" = any letter between A to W, where "Y" = any number between 1 to 9.)		
	VBHNxxxKA(01/02)	Q.PEAK DUO BLK ML-G10.C+			
	VBHNxxxSA17(G/E) & SA18(E)	Q.PEAK DUO G10+			
	VBHNxxxKA(03/04)	Q.PEAK DUO L-(G5/G5.1/G5.2/G5.3)			
	EVPVxxx	Q.PEAK DUO L-(G6/6.2/6.3)			
	EVPVxxx(H/K/PK/HK/HK2)	Q.PEAK DUO L-(G7/G7.1/G7.2/G7.3/G7.7)			
Peimar	SGxxxM (FB/BF)	Q.PEAK DUO L-(G8/G8.1/G8.2/G8.3/G8.3 BFG)			
	SMxxxM	Q.PEAK DUO L-G6.3 / BFG			
		Q.PEAK DUO ML-G12S.3 / BFG			

- Unless otherwise noted, all modules listed above include all wattages and specific models within that series. Variable wattages are represented as "xxx"
- Items in parenthesis are those that may or may not be present in a compatible module's model ID
- Slashes "/" between one or more items indicates that either of those items may be the one that is present in a module's model ID

ELECTRICAL BONDING & GROUNDING TEST MODULES: This racking system may be used to ground and/or mount a PV module complying with UL1703 or UL61730 only when the specific module has been evaluated for grounding and/or mounting in compliance with the included instructions.

Manufacture	Module Model / Series
REC	PEAK & ECO RECxxxAA (BLK/Pure/Pure-R/ Pure-RX/ Pure 2/ Pro M) RECxxxNP (N-PEAK) RECxxxNP2 (Black) RECxxxNP3 Black RECxxxPE, RECxxxPE72 RECxxxTP RECxxxTP2(BLK2) RECxxxTP2S(B)(XV) RECxxxTP3M (Black) RECxxxTP4 (Black)
Renesola	60 Cell Modules RS6-xxxNBG-E3 Vitrus2
Risen	RSM60-6, RSM72-6, RSM144-6 RSM110-8-xxxBMDG
SEG Solar	SEG-xxx-BMD-HV, SEG-xxx-BMD-TB SEG-XXX-BMB-TB, SEG-xxx-BMA-HV SEG-xxx-BMA-TB, SEG-xxx-BMB-HV SEG-xxx-BMA-BG, SEG-xxx-BMB-BG SEG-xxx-BTA-BG, SEG-xxx-BTB-BG SEG-xxx-BMD-BG, SEG-xxx-BTD-BG
S-Energy	SN72, SN60 Series SL45-60BG/BHI SL45-60MBI-xxxZ
Seraphim	SEG-(6PA/6PB/6MA/6MA-HV/6MB/E01/E11) SRP-(6QA/6QB) SRP-320-375-BMB-HV SRP-390-405-BMD-HV SRP-390-415-BMA-HV SRP-xxx-BTA-BG SRP-xxx-BTB-BG SRP-xxx-BTC-BG

Manufacture	Module Model / Series
Seraphim(Cont.)	SRP-xxx-BTD-BG SRP-xxx-BTE-BG
Sharp	ND-24CQCJ ND-25CQCS ND-F4Q300 ND-Q235F4 NU-SA NU-SC
Silfab	SILxxx(BG/BK/BL/HC/HC+/HL/HM/HN/ML/NL/NT/ NX/NU/QD/QM) SIL-xxx XL SIL-xxx XM SIL-xxx XM+ SLA-M/P SLG-M/P
Sirius	ELNSM54M-HC-BF Series ELNSM54M-HC Series
Solar4America	S4Axxx-108MH10BB, S4Axxx-72MH5BB S4Axxx-144MH10xxx, S4Axxx-144TH10xxx S4Axxx-144TH16xxx, S4Axxx-108MH10xxx S4Axxx-108TH10xxx
SolarEver USA	SE-166*83-xxxM-120N SE-182*91-xxxM-108N SE-182*105-xxxM-96-BD
Solaria	PowerXTxxxR-PD/BD/AC PowerXTxxxC PowerXT-xxxR-PM (AC) PowerX-400R
SolarTech	STU HJT STU PERC
SolarWorld	Sunmodule Protect/Plus

Manufacture	Module Model / Series
Sonali	SS-M-360 to 390 Series SS-M-390 to 400 Series SS-M-440 to 460 Series SS-M-430 to 460 BiFacial Series
Sun Edison/ Flextronics	F-Series / FLEX FXS R-Series / FLEX FXS
Suniva	MV Series Optimus Series
Sunmac Solar	M754SH-BB Series
SunPower	X-Series 72 & E-Series 72 X-Series 96 & E-Series 96 P-Series, Sig Black SPR E20 435 COM (G4 Frame) Axxx-BLK-G-AC, SPR-Mxxx-H-AC SPR-Mxxx-BLK-H-AC
SunPro	SPDGxxx-120M12
SunTech	STP XXX STPXXXS - B60/Wnhb
Talesun	Hipor M Smart TD6I72M TD7G72M TM3G48M TM3G54M TM3G66M TM7G54M TM7G60M TM7G72M TP572, TP596, TP654, TP660 TP672 TP6F72M TP6F72M(H) TP7G54M(H)

- Unless otherwise noted, all modules listed above include all wattages and specific models within that series. Variable wattages are represented as "xxx"
- Items in parenthesis are those that may or may not be present in a compatible module's model ID
- Slashes "/" between one or more items indicates that either of those items may be the one that is present in a module's model ID

ELECTRICAL BONDING & GROUNDING TEST MODULES: This racking system may be used to ground and/or mount a PV module complying with UL1703 or UL61730 only when the specific module has been evaluated for grounding and/or mounting in compliance with the included instructions.

Manufacture	Module Model / Series
Tesla	TxxxS TxxxH
Thornova	TS-BBT54(xxx) TS-BG54 TS-BG72 TS-BGT72(xxx)
Trina	DE06, DE09.05, DE09C.07 DE18M(II), DEG18MC.20(II) DE19, DEG19C.20 DEG15HC.20(II), DEG15MC.20(II), DEG15VC.20(II) PA05, PD05, DD05, DD06 PD14, PE14, DD14, DE14, DE15, DE15V(II) TSM-DE06X.05(II) TSM-DE09.05 TSM-DE09.08 TSM-DE09C.07 TSM-DEG21C.20 TSM-NE09RC.05 TSM-NE09RH.05 TSM-NE19RC TSM-NEG19RC.20 TSM-NEG21C.20
Universal Solar	UNI4xx-144BMH-DG UNI5xx-144BMH-DG UNIxxx-108M-BB UNIxxx-120M-BB UNIxxx-120MH
Upsolar	UP-Mxxx
URE	D7K_H8A D7M_(H7A/H8A) FAKxxx(C8G/E8G) FAMxxxE7G-BB FAMxxxE8G(-BB) FBKxxxM8G

Manufacture	Module Model / Series
URECO	F6MxxxE7G-BB FBMxxxM7G-BB FBMxxxMFG-BB
Vikram Solar	Eldorado, Solivo & Somera PREXOS VSMDHT.60.AAA.05 PREXOS VSMDHT.72.AAA.05 Paradea VSMDH.72.AAA.05 Paradea VSMDH.66.AAA.05
VSUN	VSUN400-415-144BMH VSUN4xx-144BMH-DG VSUN5xx-144BMH-DG VSUNxxx-108BMH VSUNxxx-108M-BB VSUNxxx-108MH VSUNxxx-120BMH VSUNxxx-120M-BB VSUNxxx-132BMH VSUNxxx-144BMH VSUNxxx-144M-BB VSUNxxx-144M-BW VSUNxxx-144MH VSUNxxx-60M-BB VSUNxxx-72MH VSUNxxxN-108BMH-BB VSUNxxxN-108BMH-BB (SoftPaw) VSUNxxxN-120BMH-BB (SoftPaw) VSUNxxxN-144BMH VSUNxxxN-144MH
Waaree	Arka Series WSMDi
Winaico	WST & WSP Series

Manufacture	Module Model / Series
Yingli	YGE 60 Cell YGE 60 Cell Series 2 YLM 60 YLM 72 YLM-VG
Yotta Energy	YSM-B450-1
ZNShine Solar	ZXM6-72 Series ZXM6-NH120 Series ZXM6-NH144 ZXM6-NHLDD144-XXX/M ZXM7-SH108 Series ZXM7-SHDB144 ZXM7-SHLDD144 ZXM7-UHLDD144 ZXM8-GPLDD132 Series ZXM8-TPLDD132

- Unless otherwise noted, all modules listed above include all wattages and specific models within that series. Variable wattages are represented as "xxx"
- Items in parenthesis are those that may or may not be present in a compatible module's model ID
- Slashes "/" between one or more items indicates that either of those items may be the one that is present in a module's model ID