



# INSTALLATION GUIDE



## UNIRAC Code-Compliant Installation Manual

© 2022 by Unirac, Inc. All rights reserved.



# INSTALLATION GUIDE

---

## TABLE OF CONTENTS

TOOLS & SPECIFICATIONS .....	1
SYSTEM COMPONENTS.....	2-3
LOCATE ARRAY & PLACE BAYS .....	4
PLACE BALLAST & SOUTH MODULES.....	5
MODULE PLACEMENT & ATTACH CLAMPS .....	6
MID SUPPORT INSTALLATION.....	7-8
BALLAST BAY WIND DEFLECTORS.....	9
BALLAST BAY ROOF ATTACHMENT .....	10
MICROINVERTER INSTALL & WIRE MANAGEMENT. ....	11
GROUNDING LUGS.....	12
ELECTRICAL DIAGRAM.....	13
TEMPORARY BONDING PROCEDURES.....	14
SYSTEM LEVEL FIRE CODE COMPLIANCE .....	15
MECHANICAL LOAD TESTING.....	16
COMPATIBLE MODULES .....	17-21

## GENERAL NOTES:

If provided refer to construction drawings for project specific details.  
Construction drawings have precedence over these installation guidelines.

### TECHNICAL SPECIFICATIONS:

Material Types: 16G ASTM A653 GR50 Steel

Coating(s): G235 Galvanization, G180 Galvanization, G40 Galvanization + InterCoat® ChemGuard, G60 Galvanization + InterCoat® ChemGuard or G80 Galvanization + InterCoat® ChemGuard

Hardware: Stainless Steel

Bonding and Grounding: UL2703 Listed Continuous Bonding Path.

### TOOLS REQUIRED OR RECOMMENDED FOR LAYOUT, ATTACHMENTS & INSTALLATION:

- Drill (**Do Not Use An Impact Driver**)
- 7/16" Socket
- Torque Wrench
- Tape Measure
- Chalk Reel
- Optional Spacers (See Diagram - Page Right)

### GENERAL HARDWARE:

- ¼-20 X 2 ½" Hex Head Bolt - Module Clamps
- ¼-20 X 1" Hex Head Bolt - Wind Deflectors
- ¼-20 Stainless Steel U-Nuts
- ¼" Flat Washer 1 ½" O.D.

### SAFETY:

All applicable OSHA safety guidelines should be observed when working on a PV installation job site. The installation and handling of PV solar modules, electrical installation and PV racking systems involves handling components with potentially sharp metal edges. Rules regarding the use of gloves and other personal protective equipment should be observed.

### LAYOUT ASSISTANCE TOOL:

Module Dimensions:	RM5	Module location:	Spacing Equations (in Inches):	
			For 7.5" inter-row option:	For 11" inter-row option:
Module Length (ML) =	1	Perimeter Column Spacing =	$ML + (G/2) - 32.04"$	
Module Width (MW) =	2	Interior Column Spacing =	$ML + G - 21.36"$	
Preferred module gap? (1/4" - 1" is permissible)	3	South Row Spacing =	$(MW \times 0.996) - 12.79"$	$(MW \times 0.996) - 12.79"$
	4	Row Spacing =	$(MW \times 0.996) - 12.79"$	$(MW \times 0.996) - 9.25"$
East/West Module Gap (G) =	5	North Row Spacing =	$(MW \times 0.996) - 21.97"$	$(MW \times 0.996) - 18.46"$

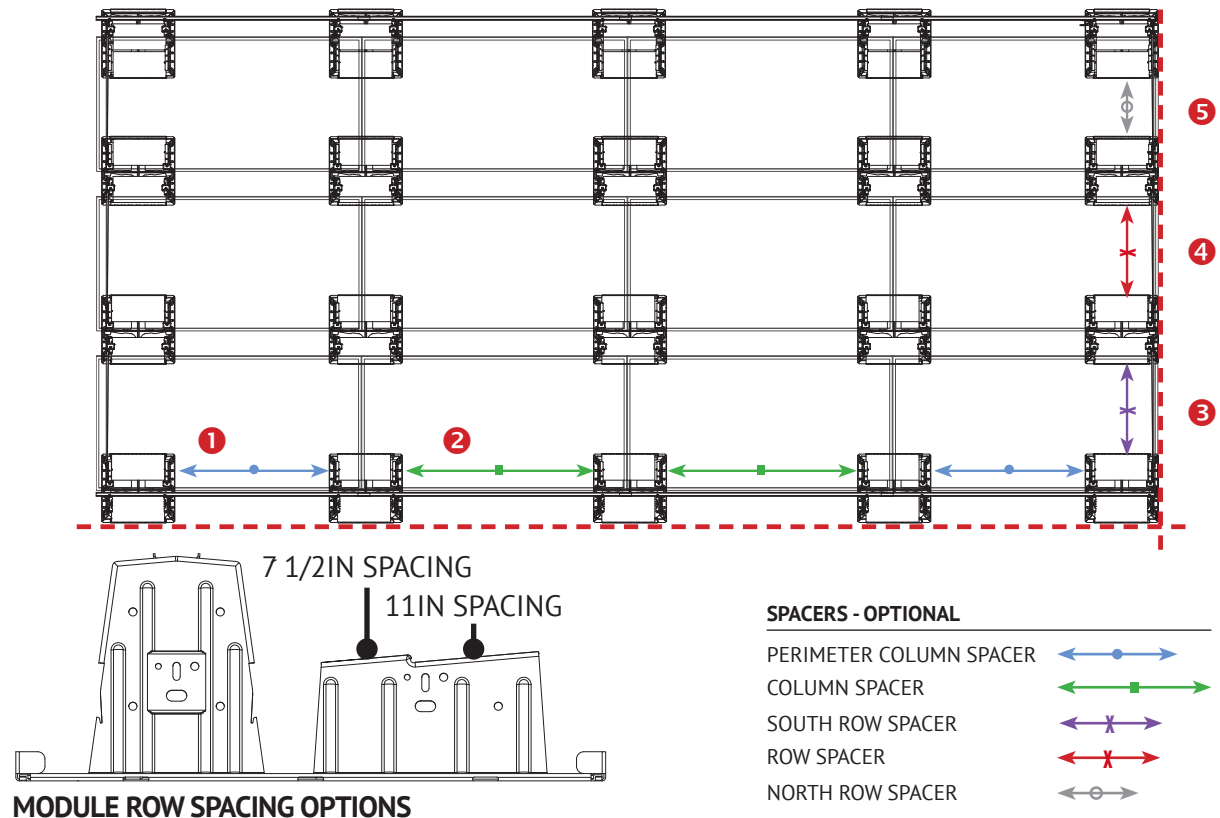

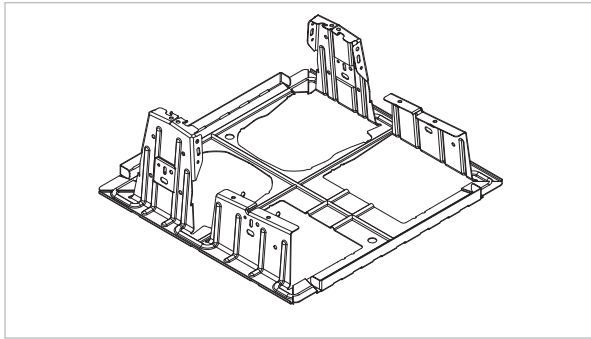

**BALLAST BAY:** The Ballast Bay is constructed of a high strength low alloy steel with a coating to protect against corrosion. This system has a modular design that allows for easy installation around roof obstructions and accommodates roof undulations. The Ballast Bays are designed to nest within each other to optimize shipping logistics. **NOTE: Systems installed on PVC roofs require ballast bays with pre-installed Santoprene pads.**

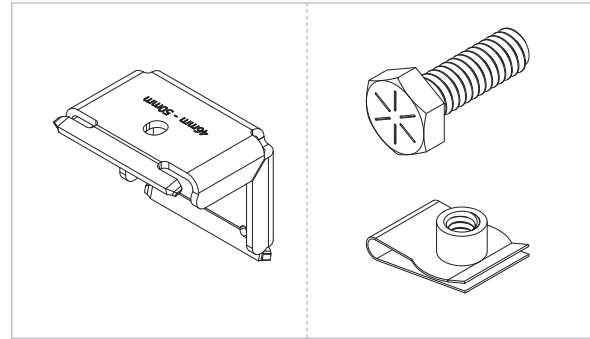

**CLAMP & HARDWARE:** The Module Clamp is made of Stainless Steel and can be used with module frame heights indicated on the clamp. The clamps are a portion of the UL2703 Listed system when installed according to this installation guide. A 1/4"-20 stainless steel bolt and u-nut are the associated hardware for installing clamps. **NOTE: U-Nuts come in packages separate from Clamp Kit.**

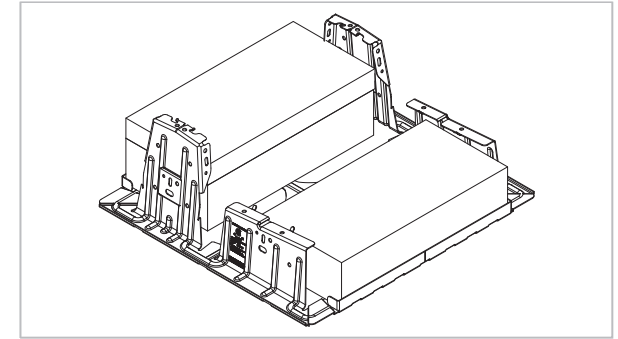

**BALLAST BLOCK:** The RM ballast bay can fit up to 2 1/2 standard 4"x8"x16" solid concrete cap blocks. Block weight can range from 26 – 38 lbs. and shall meet ASTM C1491 requirements for freeze thaw durability. Verify your block weights before using the Unirac U-Builder online design tool.

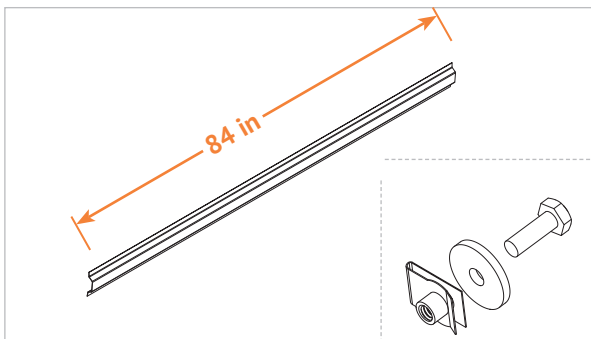

**WIND DEFLECTOR:** 18G G180 steel wind deflector aids in ballast reduction and provides fire mitigation. A 1/4" - 20 stainless steel bolt and fender washer (1.5" O.D) are associated hardware for wind deflectors. **NOTE: U-Nuts come in packages separate from deflector hardware.**

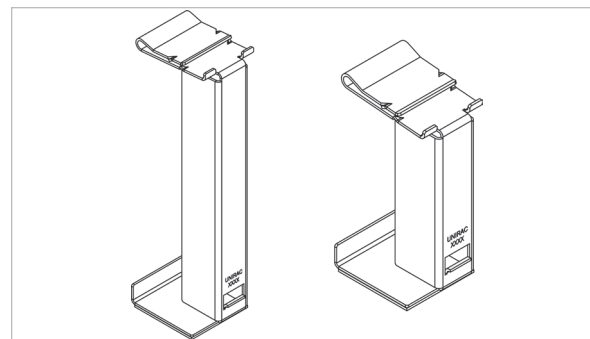

**MID SUPPORTS:** Mid Supports are made of Galvalume steel and provide additional downforce support for large modules as well as heavy wind and snow loads.

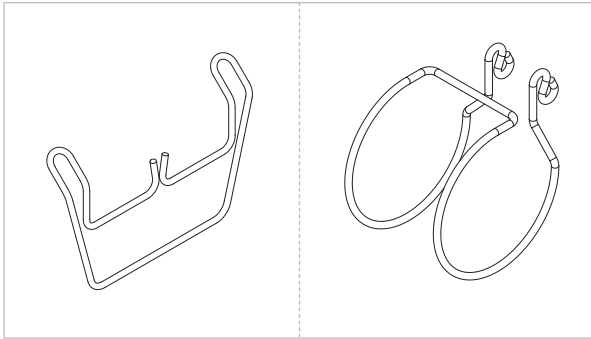

**OPTIONAL WIRE MANAGEMENT:** Custom Unirac wire clip along with mounting options for various off the shelf wire management clips.

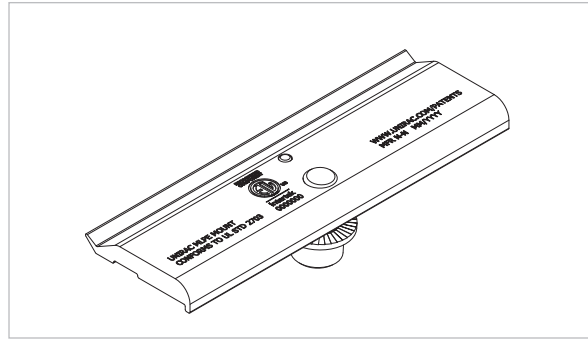

**OPTIONAL MICROINVERTER MOUNTING:** Microinverter / Power optimizer bracket, see page 11 for additional instructions.

**NOTE:** All conduit and wire ways should be grounded & bonded per the (NEC) National Electric Code.

### PART NUMBER DATA

S.No.	Part Number	Part Description
1	310800	RM5 BAY
2	310803	RM5 BAY, PVC
3	310810	RM5 WIND DEFLECTOR, 84"
4	310811	RM5 WIND DEFLECTOR, 98"
5	310820	RM5/DT ENDCLAMP 30-40MM
6	310821	RM5/DT ENDCLAMP 41-45MM
7	310822	RM5/DT ENDCLAMP 46-50MM
8	310830	RM5/DT PVC ROOF FRICTION PATCH
9	310850	RM5/DT WIRE MGMT CLIP
10	310851	RM5 WD WIRE MGMT CLIP
11	310860	RM5/DT 1/4-20 CLIP U-NUT SS18-8
12	310861	RM5, WIND DEFLECTOR HDW KIT
13	008114M	MLPE MOUNT ASSY

S.No.	Part Number	Part Description
14	205000S	ENPHASE ENGAGE CABLE CLIP
15	008002S	GROUND WEEBLUG #1
16	008009P	ILSCO LAY IN LUG (GBL4DBT)
17	310999	FLASHLOC RM KIT
18	310835	RM5 MID SUPPORTKIT

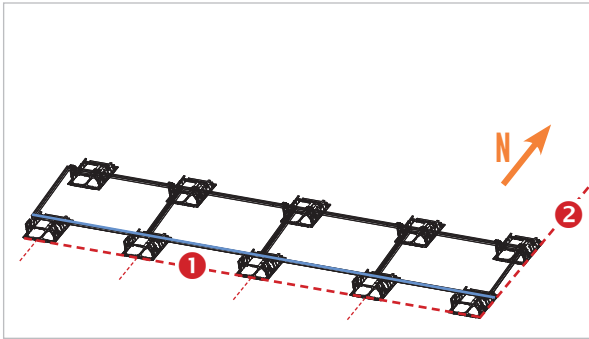

**SNAP SOUTH PERIMETER CHALK LINE, THEN EAST OR WEST PERIMETER CHALK LINE.** As best practice, on south edge of array mark lines to locate the center of each bay.

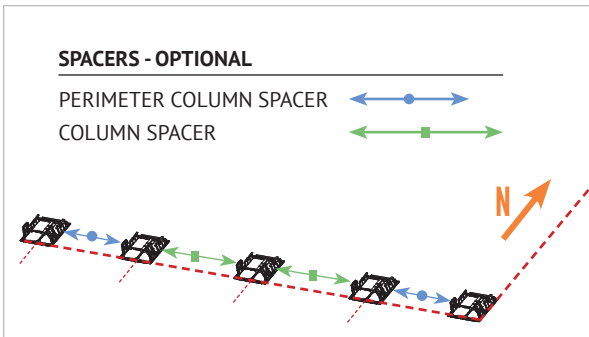

**PLACE SOUTH PERIMETER BAYS FIRST.** If slip sheets are required, place per manufacturers recommendations.

**NOTE:** Custom spacers can be made to aid in the placement of bays on the roof. See page 1

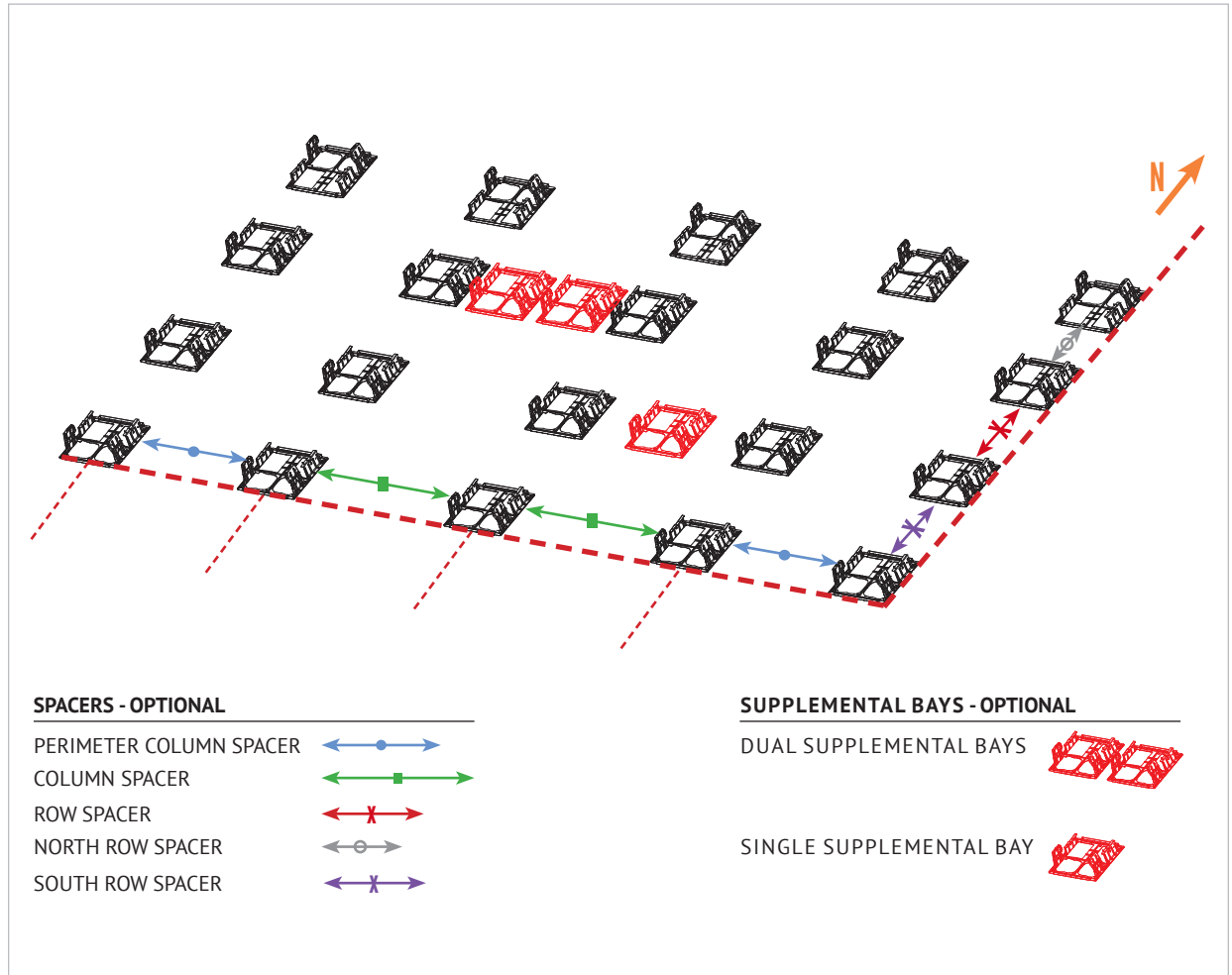

**PLACE ALL BAYS.**

**NOTE:** If mechanical attachment is required, place prior to installation of modules.

**NOTE:** If supplemental bay is required, install after the primary bays are installed. Supplemental bay needs to be centered in between primary bays.

**PLACE ALL BALLAST:** A maximum of two and half (2 1/2) ballast blocks can be placed in each ballast bay, typically pushed into the retention feature on the north or south edge. The North perimeter requires ballast blocks to be pushed towards the southern edge of the ballast bay to accommodate wind deflectors. Site specific ballast calculations should be created for each individual project in accordance with the U-Builder design software. This system has been rated for the mechanical load provisions of UL2703. In addition, it has been designed and tested to comply with the more rigorous requirements of SEAOC PV1, PV2 and ASCE 7.

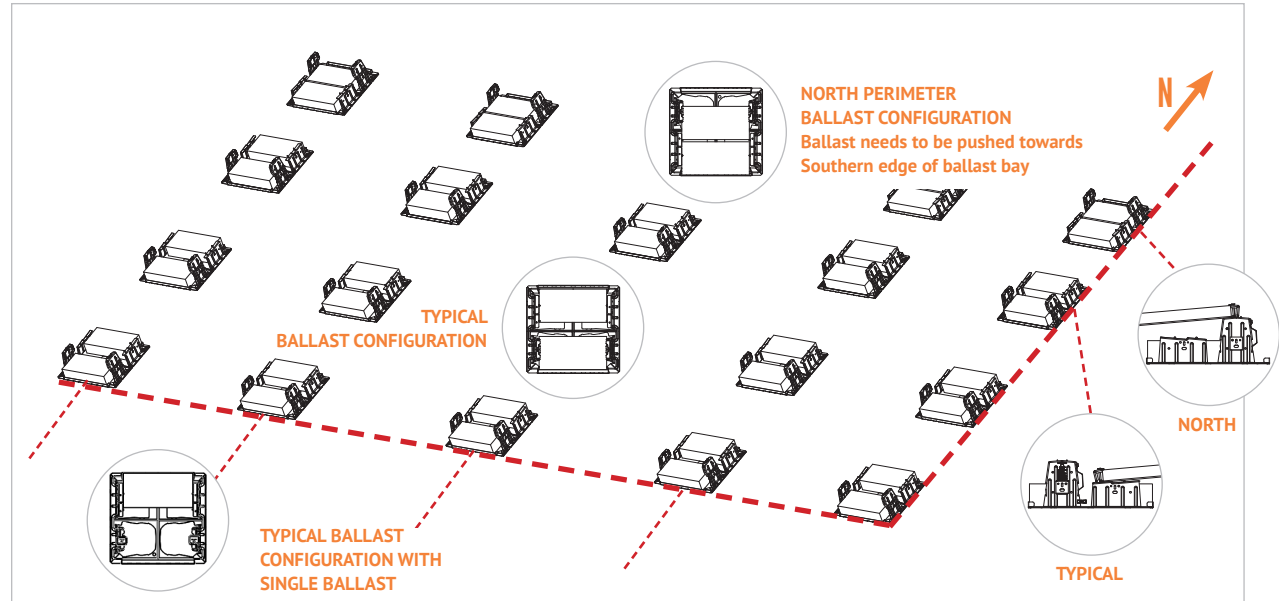

**SOUTHERN EDGE MODULE PLACEMENT:** Each bay has two spacing options, select the appropriate tab according to layout requirements.

Place southern row of modules on bays. You may adjust second row of bays. Do not adjust southern most row of bays

1 IN. Maximum gap between modules

1/4 IN. Minimum gap between modules

**NOTE:** Modules may be placed on bays without immediate installation of clamps.

**NOTE:** Modules shall be mounted in landscape orientation only.

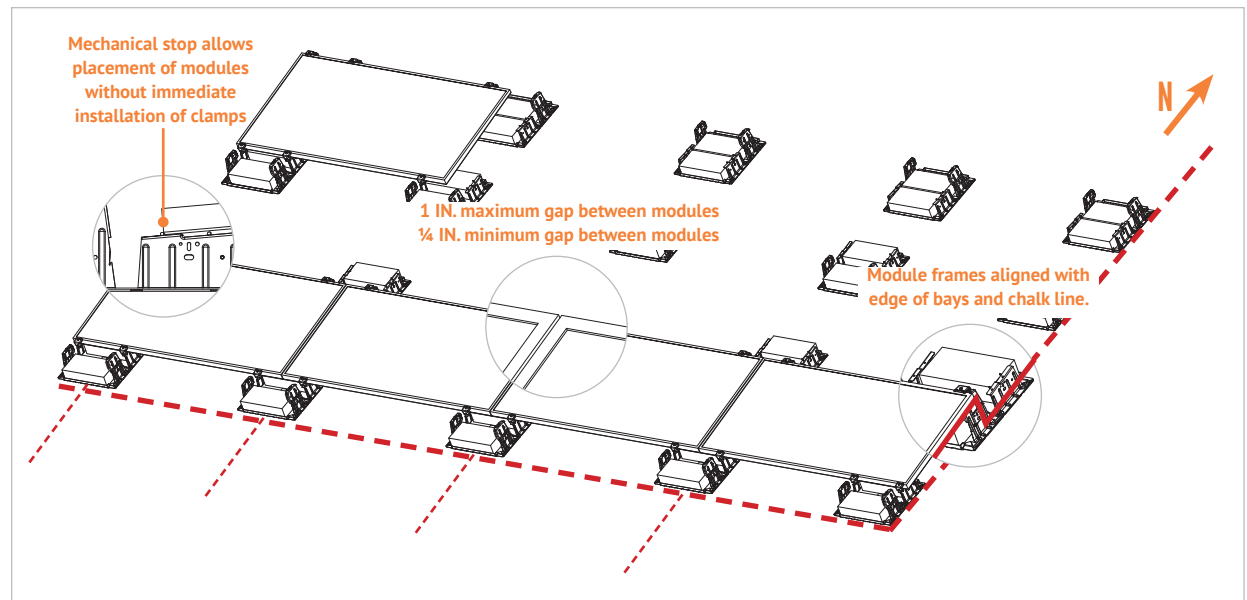

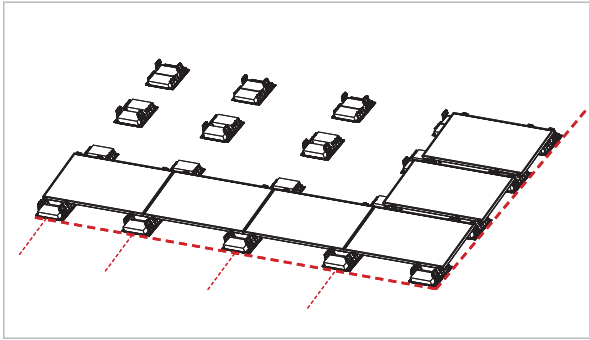

### EAST OR WEST EDGE MODULE PLACEMENT

**NOTE:** Modules may be placed on bays without immediate installation of clamps.

**NOTE:** Modules shall be mounted in landscape orientation only.

**NOTE:** Install wind deflector at the time of module installation. See page 9 for installation guide.

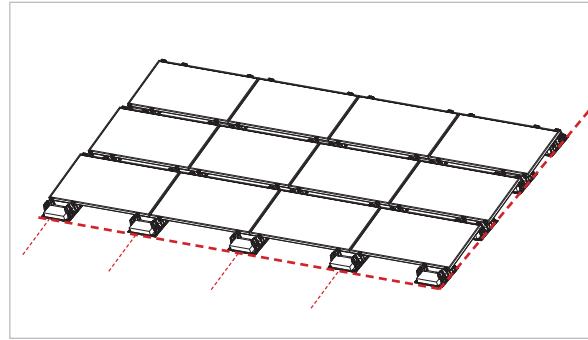

### COMPLETE MODULE PLACEMENT

**NOTE:** Wiring, wire management, and electrical QC should be done as each row is built, especially in case of 7.5" row spacing to ensure adequate room for installation.

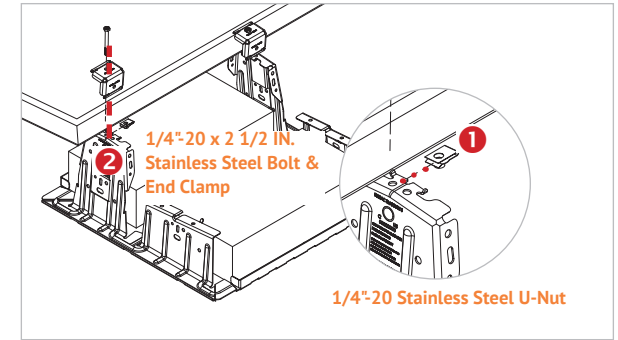

### INSTALL U-NUT & INSTALL CLAMPS

**NOTE:** U-NUT - Single Use Only - Do not re-torque once fully seated

**NOTE:** CLAMP AND BOLT - Single Use Only - Do not re-torque once fully seated

**TORQUE VALUE:** 7FT-LBS to achieve UL2703 required clamp load

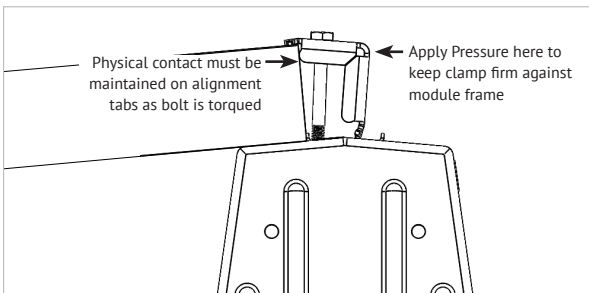

### PROPER CLAMP INSTALLATION:

- Clamp is stamped for module frame height on each leg
- Clamp should be firmly held against module frame while being torqued



### PROBLEM – CLAMP NOT SEATED AGAINST MODULE DURING TORQUING

- Clamp needs to be held securely against the module frame during torquing for proper installation

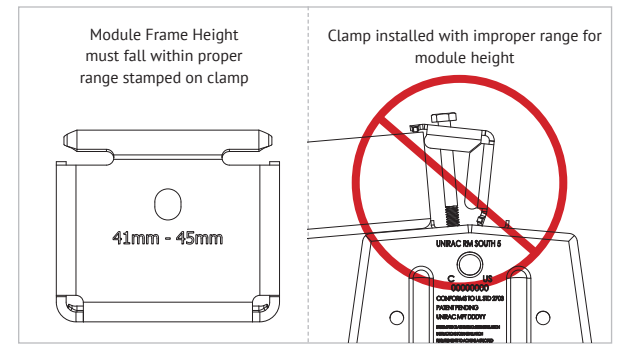

### PROBLEM – NOT USING PROPER SIZE OF CLAMP FOR MODULE FRAME HEIGHT

- Double check the stamping on clamp to use the correct leg of clamp for module frame height
- The module height shall fall within the range shown on the top of the clamp
- Excessive angle on clamp will inhibit required clamp load on module

## INSTALLING NORTH AND SOUTH MID SUPPORTS

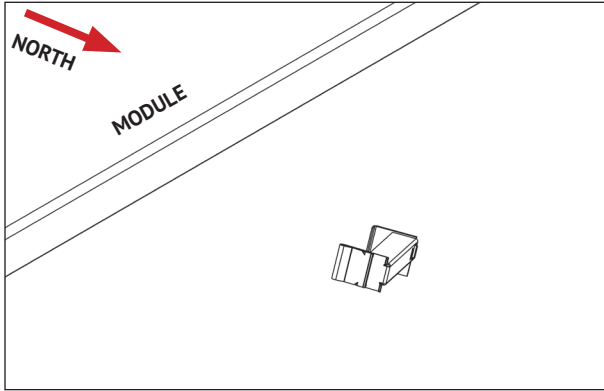

**STEP 1:** To install the North mid support, tilt it horizontally as shown in the figure and insert it under the module's North side.



While inserting the midsupport, make sure not to scrape the roof surface with the metal edge.

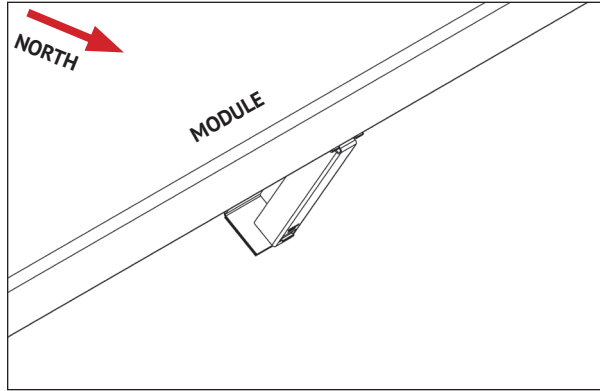

**STEP 2:** Using the PV module cell lines, locate the module centre point (+/- 1"). Tilt back midsupport to engage it to module flange



While tilting the south midsupport, make sure not to scrape the roof surface with the metal edge.

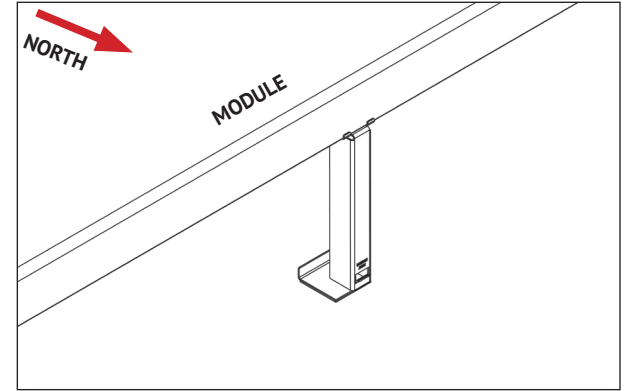

**STEP 3:** Pull the midsupport onto the module flange. Ensure the midsupport is fully engaged.

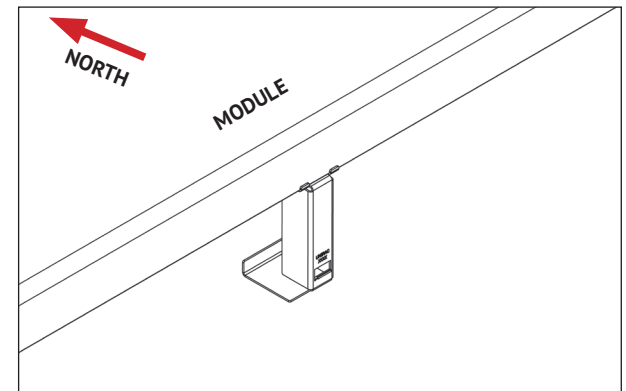
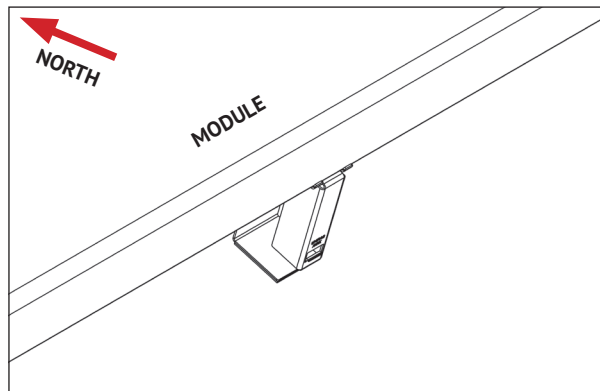
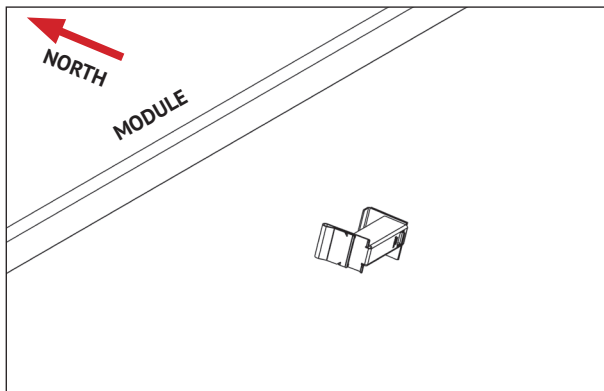

**NOTE:**

Similarly, we can install the south midsupport by following the STEP 1 to STEP 3

## INSTALLING MID SUPPORTS ON ROOF UNDULATIONS

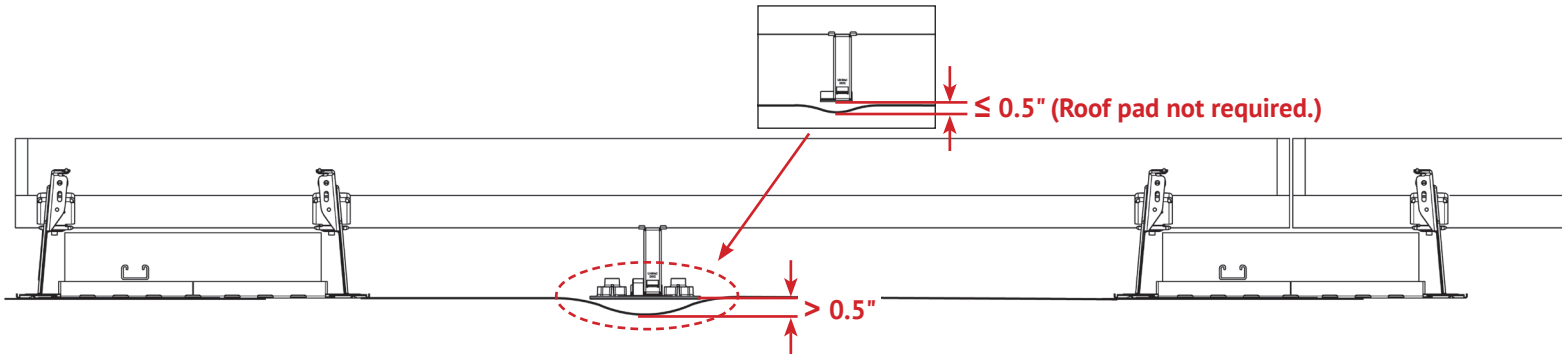

### CASE 1: MID SUPPORT AT THE VALLEY OF ROOF UNDULATION

- Place the roof pad (P/N: 360060) directly under the mid support at the valley of the roof undulation if the gap is greater than 0.5 inches.
- Stack additional roof pads until the gap between roof pad and mid support is less than or equal to 0.5 inches.
- Ensure the roof pads are aligned properly and provide a stable base for the mid support.

**Note:** A roof pad is not required if the gap at the roof undulation is 0.5 inch or less.

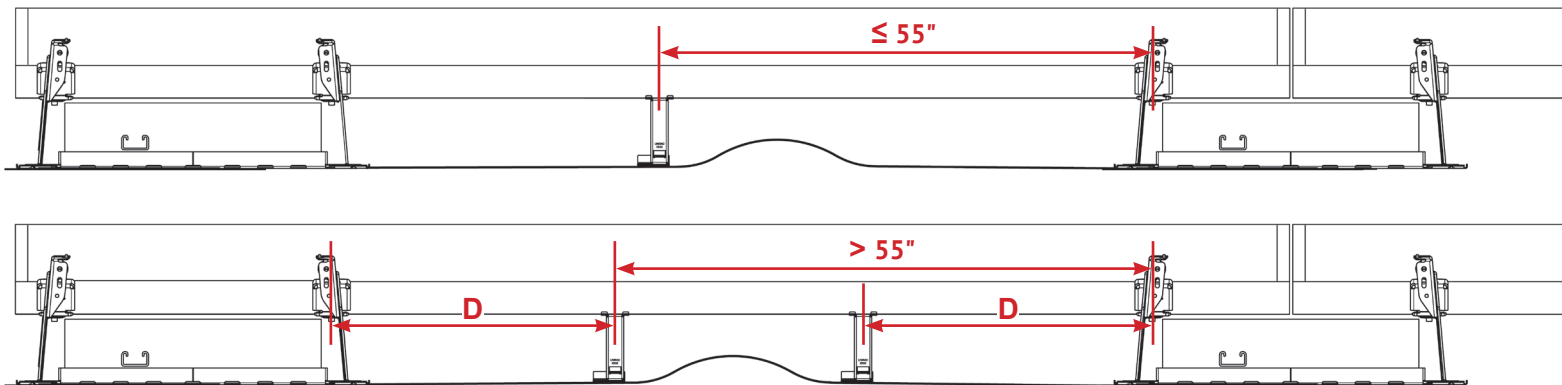

**D: Distance between Mid Support and Module Clamp**

### CASE 2: MID SUPPORT AT THE PEAK OF ROOF UNDULATION

- Slide mid support to either side of undulation so that it lands on flat surface.
- If distance between mid support and farthest module clamp on same module exceeds 55 inches, add another mid support symmetrically to the previous mid support.

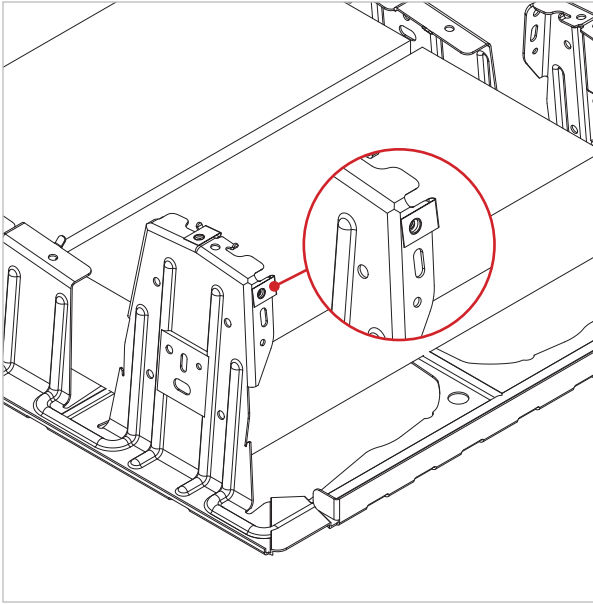

**STEP 1 - U-NUTS:**  
Install u-nuts on side flange

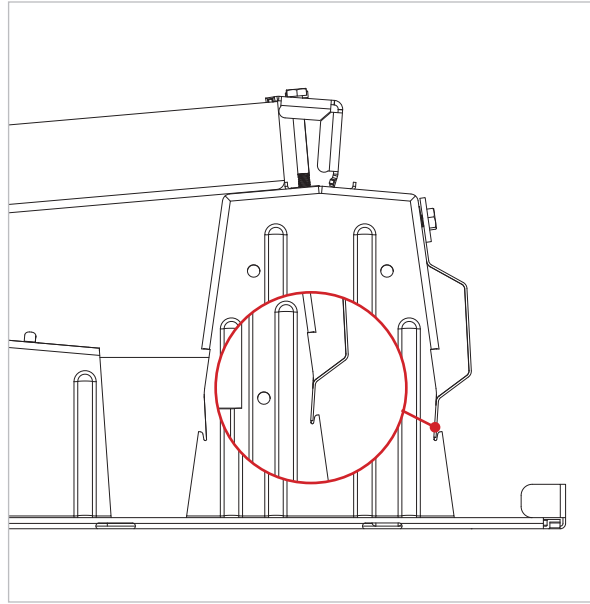

**STEP 2 - WIND DEFLECTOR:**  
Position wind deflector in the slots provided in the bay

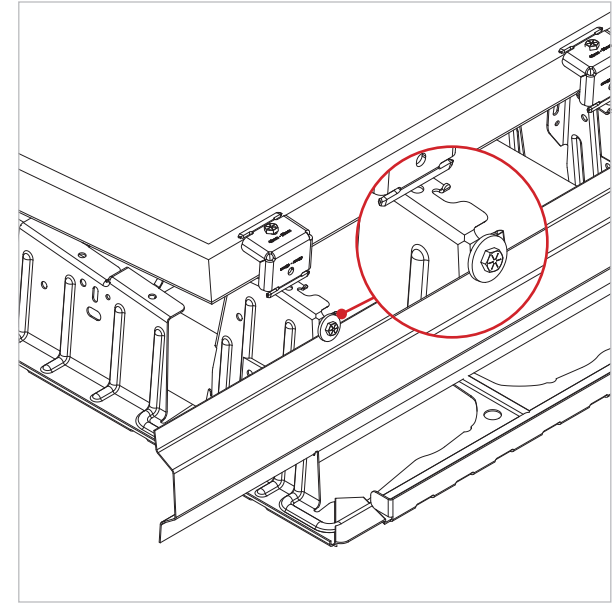

**STEP 3 - HARDWARE:** Secure wind deflector with 1 ½" O.D. flat washer and ¼-20 x 1" Bolt, as shown above

**TORQUE VALUE: 10FT-LBS**

**NOTE:** If the system requires wind deflectors do not leave arrays without installing wind deflectors. Wind deflectors are critical aerodynamics components in the case of any wind event.

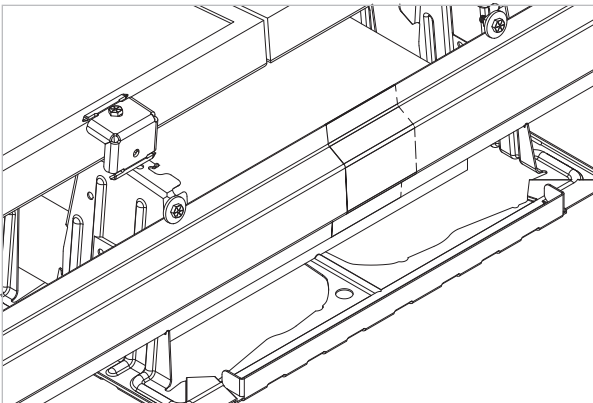

**INSTALL BALLAST BAY WIND DEFLECTORS**

**NOTE:** Wind deflectors overlap at splice

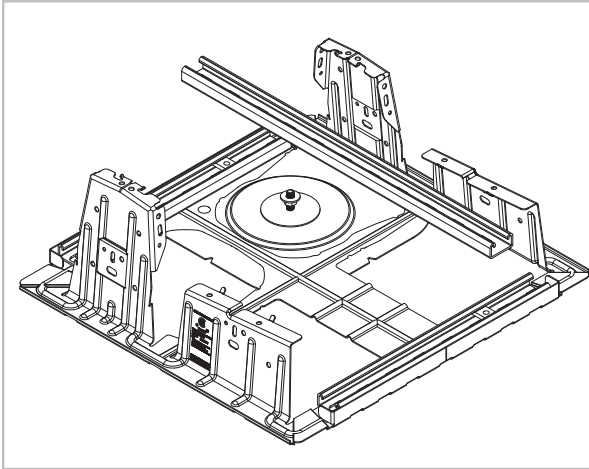

**STEP 1 - PLACE NUT AND WASHER:**

Include the nut and washer on the anchor stud prior to placing the stud through the strut.

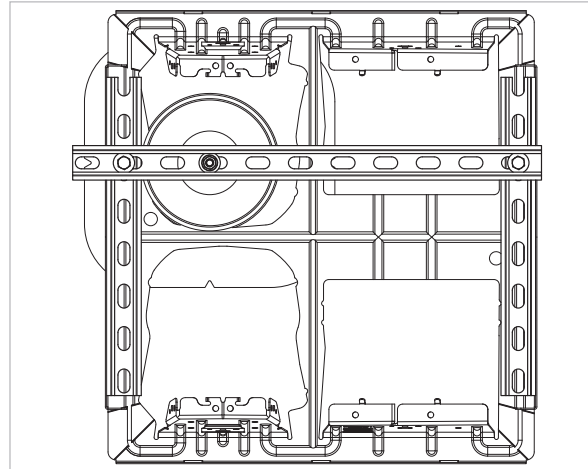

**STEP 2 - POSITION ROOF ATTACHMENT:**

Position Roof Attachment under bay requiring attachment and install according to manufacturer installation instructions.

**NOTE:** Position attachment so that it is close to center of the bay as possible.

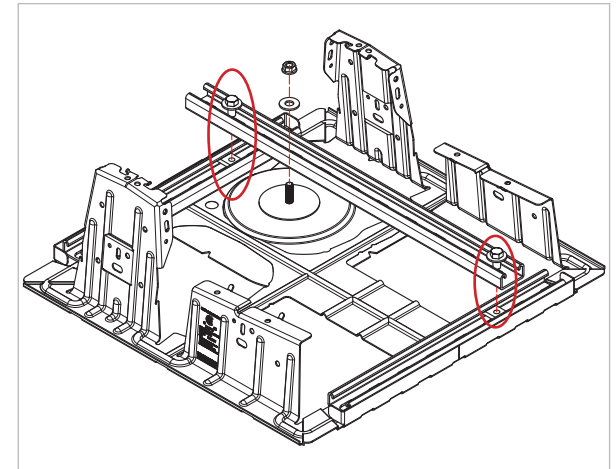

**STEP 3 - PLACE UNISTRUT:** Position strut sections on bay as pictured above. Align the cross-strut with the anchor's stud. Connect side strut sections to cross strut using a strutnut, bolt, and washer as pictured.

**NOTE:** Metal base of attachment where stud is located cannot exceed a height of 1/4".

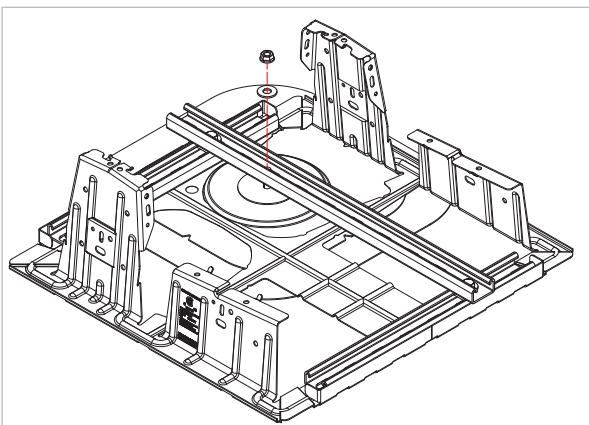

**STEP 4 - SECURE UNISTRUT TO ROOF**

**ATTACHMENT:** Place 3/8" washer and 3/8-16 serrated flange nut on anchor stud, serrations facing down and tighten to 30 ft-lb.

**TORQUE VALUE: 30FT-LBS**

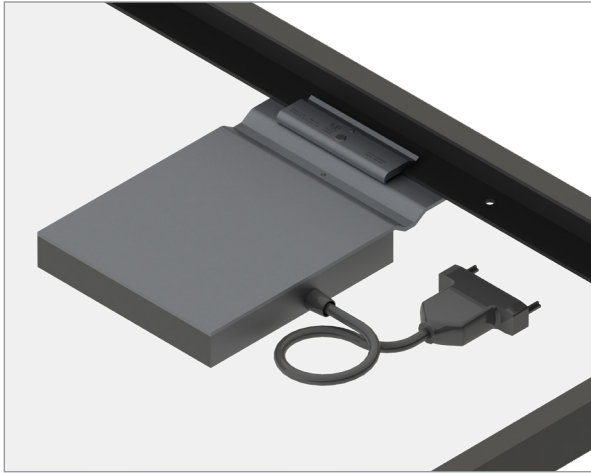

**PRE-INSTALL MICROINVERTERS:** Install MLPE in a location on the module that will not interfere with ballast bays or grounding lugs. To use trunk cable most efficiently, install MLPE components in the same locations on all modules in the same row.

**TORQUE VALUE: 20FT-LBS**



**GROUNDING LUG MOUNTING DETAILS AS REQUIRED BY CODE & ENGINEER OF RECORD:** The IlSCO lug has a green colored set screw for grounding indication purposes. One lug is recommended per continuous array, not to exceed 150ft X 150ft.

Unirac ROOFMOUNT is intended to be used with PV modules that have a system voltage less than or equal to that allowable by the National Electric Code (NEC). It is the installer's responsibility to check adherence to local codes.

**NOTE: The installation must be conducted in accordance with the National Electric Code ANSI / NFPA 70.**

Ground Lug	Bolt Size	Torque Value
IlSCO Lug SGB-4	1/4"-20	6.5 ft-lbs (75 in-lbs)
IlSCO Lug GBL-4	#10-32	2.9 ft-lbs (35 in-lbs)
Wiley 6.7	1/4"-20	10 ft-lbs (120 in-lbs)

**NOTE: In order to prevent corrosion induced by dissimilar metals, it is important to verify that the bare copper wire does not come into contact with aluminum or galvanized steel. These materials must be kept separate.**

Although conformance with UL2703 was demonstrated without the use of oxide inhibitor material, it is recommended by IlSCO to provide an optimized bonding solution for their lay-in lug.

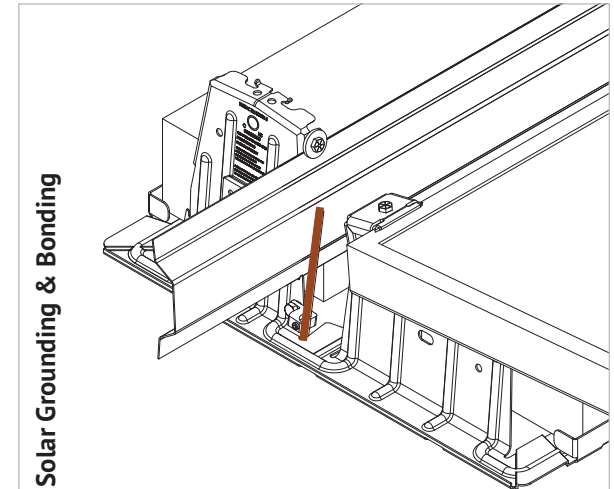

All Lugs Solar Grounding & Bonding

**GROUNDING NOTE:**  
Can be installed on any location with a flat surface on the bay in order to ground the system.

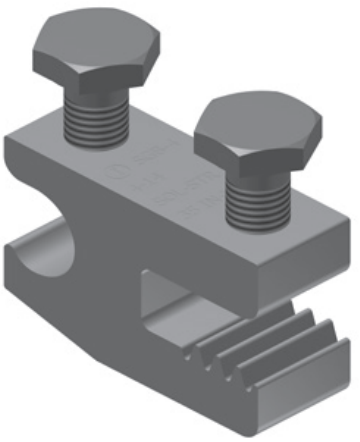

**IlSCO SGB-4 Solar Grounding & Bonding**

**TERMINAL TORQUE:**  
Install conductor and torque to the following: 4-14 AWG: 35 in-lbs

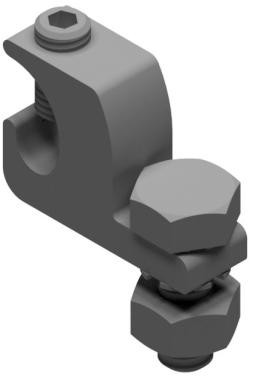

**IlSCO GBL-4 Solar Grounding & Bonding**

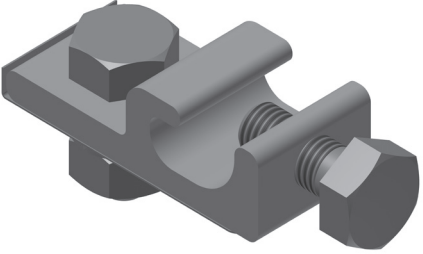

**TERMINAL TORQUE:**  
Install Conductor and torque to the following: 4-6 AWG: 35 in-lbs, 8AWG: 25 in-lbs

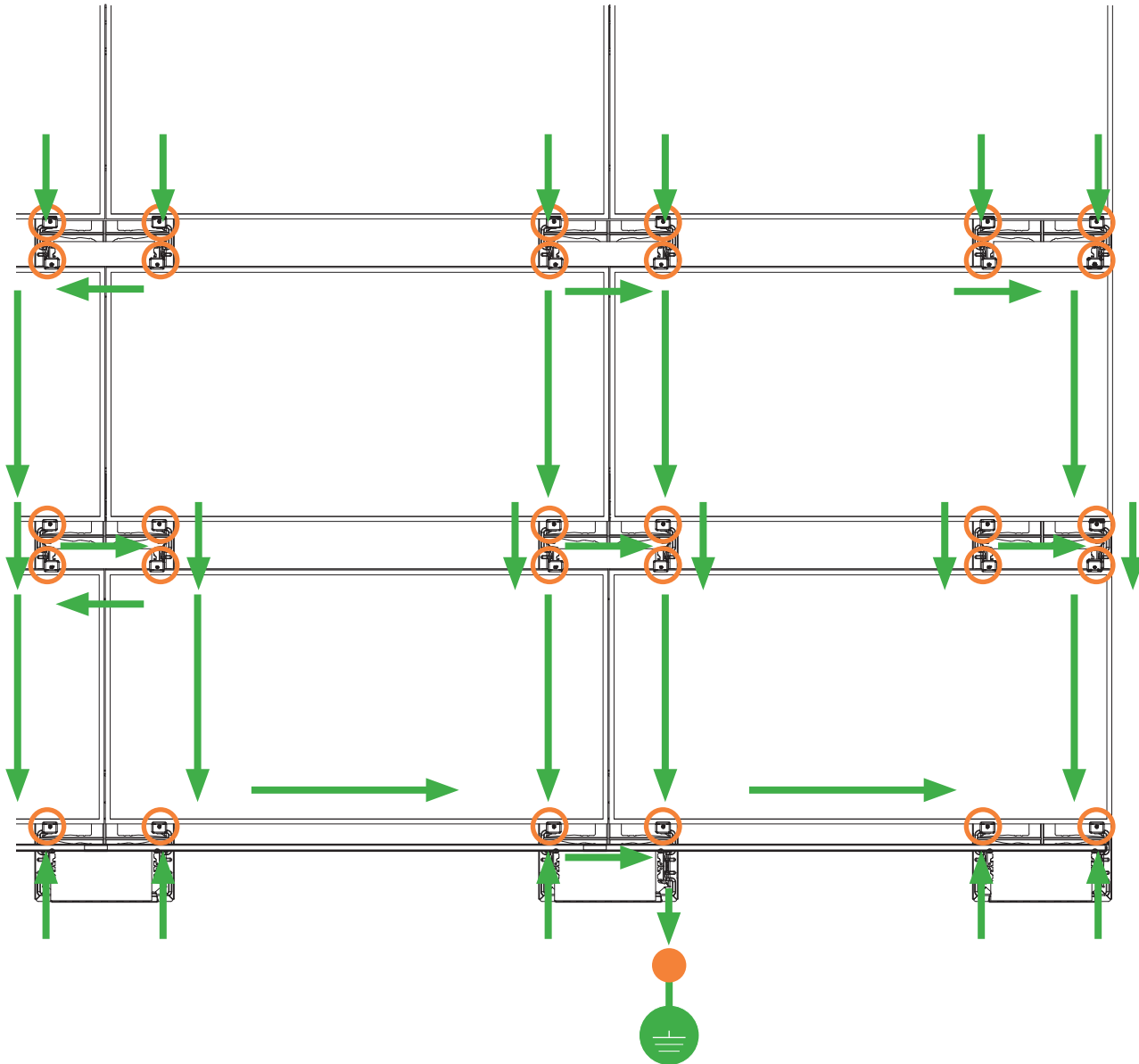

**Wiley WEEB-Lug 6.7 Solar Grounding & Bonding**

**TERMINAL TORQUE:**  
Install Conductor and torque to the following: 4-6 AWG: 10 ft-lbs, 6-14 AWG: 7 ft-lbs



-  Fault Current Ground Path
-  Ground Lug
-  Grounding Clip & Bolt
-  Min. 10 AWG Copper Wire

Module Frame  
 Module Bay w/ Grounding Clips

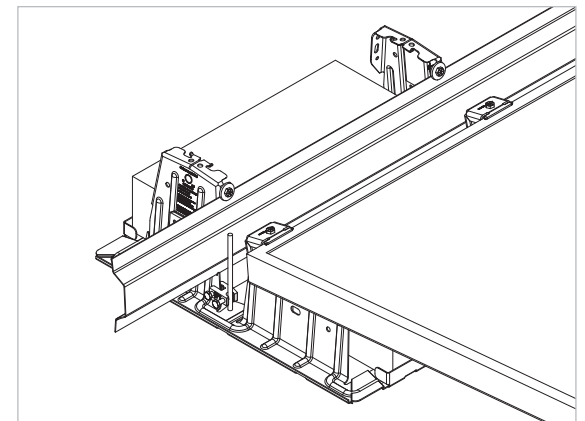

**TEMPORARY GROUNDING & BONDING PROCEDURE:** Periodic inspections should be conducted on the PV array to ensure there are not loose components, loose fasteners or corrosion. If any of the above items are found, the affected components are to be immediately replaced.

**Note**

- If a module must be removed or replaced, a temporary bonding jumper must be used to ensure safety of the personnel and PV system.
- Removing a PV module from a system is not considered to be routine maintenance. This type of activity should only be performed by trained and qualified installers.
- In order to prevent corrosion induced by dissimilar metals, it is important to verify that the bare copper wire does not come into contact with aluminum or galvanized steel. These materials must be kept separate.

APPROVED LUGS and Terminal Torque see page 12

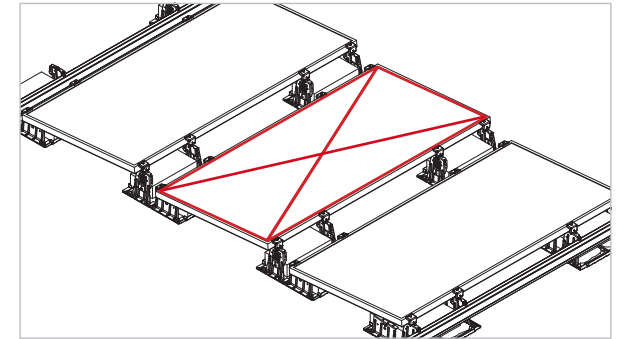

**BONDING JUMPER REQUIRED:** One example of a module removal that will require the use of a bonding jumper

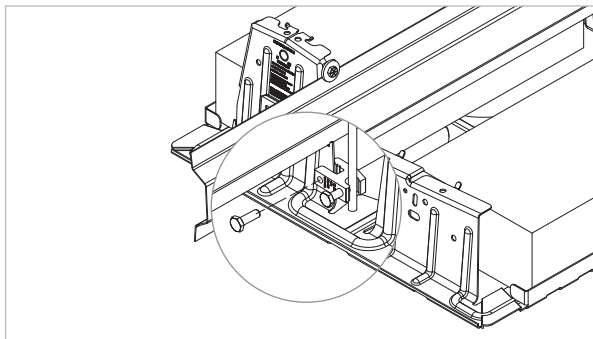

**ATTACH LUGS:** Use approved lug(s) to install on adjacent bays where the module is being removed.

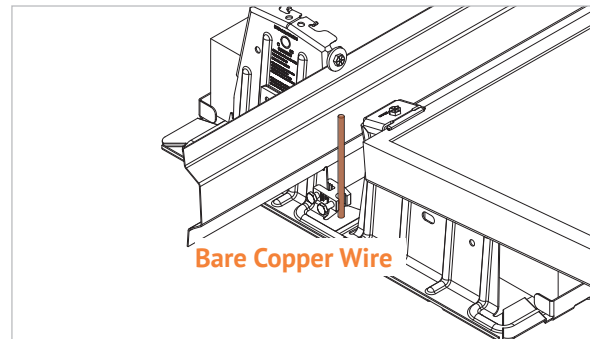

**INSERT COPPER WIRE:** Insert bare copper wire into each lug, providing a bonding jumper across the missing module location.

Remove module & reverse the operation after maintenance is complete

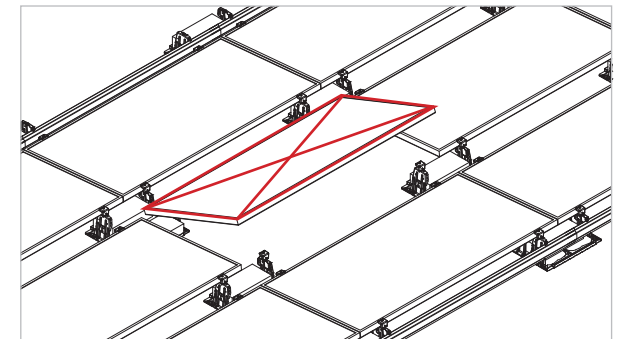

**BONDING JUMPER NOT REQUIRED,** due to integrated bonding/grounding path throughout module frames/bays around this location.

**NOTE: CLAMP AND BOLT - Single Use Only - Use new clamps after any module replacements or system maintenance.**

**SYSTEM LEVEL FIRE CLASSIFICATION:** The system fire class rating is only valid when the installation is conducted in accordance with the assembly instructions contained in this manual over a fire resistant roof covering rated for the application. RM ROOFMOUNT has been classified to the system level fire portion of UL2703. It has achieved Class A performance for low sloped roofs when used in conjunction with type 1, 2, 29, and 30 module constructions. Please see the specific conditions below for mounting details required to maintain the Class A fire rating. Minimum and maximum roof slopes are restricted through the system design and layout rules. The fire classification rating is only valid on roof pitches less than 2:12 (slopes < 2 inches per foot, or 9.5 degrees).

Refer to page right for proper installation of wind deflectors for required fire mitigation.

**NOTE:** Fire Type information is generally located on back of modules or through manufacturer's documentation. Some building codes and fire codes require minimum clearances around such installations, and the installer should check local building code requirements for compliance.

Unirac RM  
CONFORMS TO UL STD2703

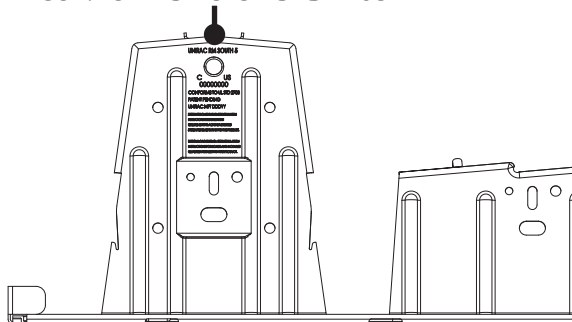

Module Type	System level Fire Rating	Mitigation
Type 1, 29, & 30	Class A	Prescriptive. See notes & Illustration Below
Type 2	Class A	Prescriptive. See notes & Illustration Below

### TYPE 1 / TYPE 2 CLASS A FIRE RATING MOUNTING ORIENTATION

Unirac RM has achieved Class A system level fire performance for type 1, 2, 29, and 30 module constructions. In order to maintain the fire rating for type 1, 29, & 30 modules wind deflectors must be installed on the north edge of the array. Type 2 modules require wind deflectors to be installed on the north and south edges of the array and at all perimeter modules.

**NOTE:** See page 9 for installation of wind deflectors.

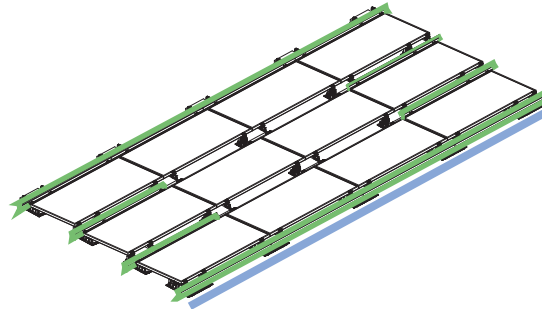

Please use the U-builder tool to optimize the usage of wind deflectors for fire mitigation.

- Type 1, 29, & 30 Requires fire mitigation on North Edge when there are no additional wind deflectors throughout the array
- Type 2 Requires fire mitigation on all perimeter modules within array.

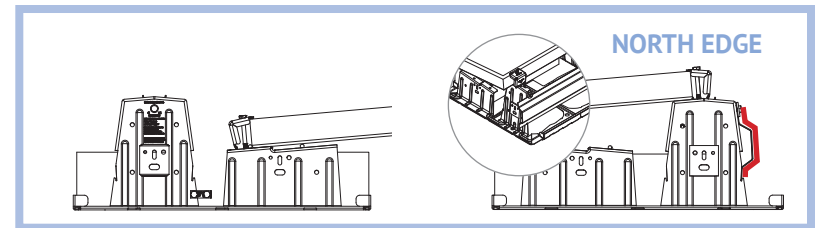
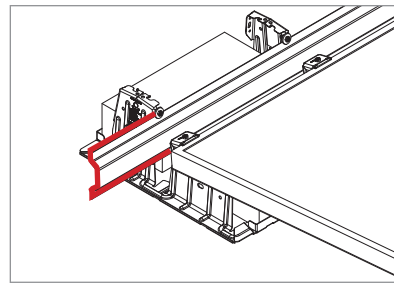

**TYPE 1, 29, & 30:** Install wind deflectors on North edge of array.

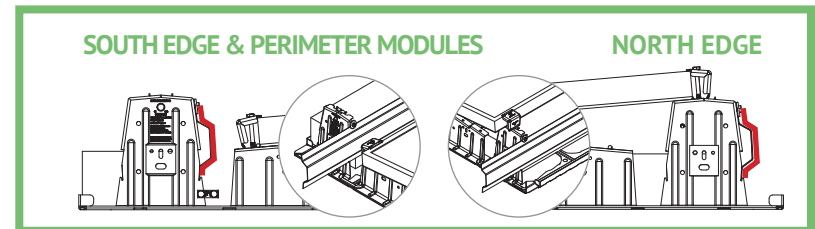

**TYPE 2:** Install wind deflectors on all perimeter modules within array  
**NOTE:** Wind deflector should be secured to supplemental bay by two hardware kits.

**TYPE 2 EAST/WEST EDGES ONLY:** Install wind deflectors in each row with 6" overhang on east and west edges. This applies for any deflector installed on east and west edges throughout the array.

**TORQUE VALUE: 10FT-LBS**  
**All Wind Deflector Hardware**  
(1/4-20 x 1inch bolt, 1/4-20 u-nut & 1/4inch flat washer 1 1/2in O.D.)

## MECHANICAL LOAD TEST

The Unirac RM system has been tested to the mechanical load provisions of UL2703 and covers the following basic parameter(s):

- Test Loads = 1.5 x Design Loads
- PV modules may have a reduced load rating, independent of the RM5 load rating. Please consult the PV module manufacturer's installation guide for more information.

## TESTED MODULES

Module Manufacturer	Model / Series	Area (sq ft)	Standard Installation Configuration - No Mid Bay		Installed with Additional Bay at Modules East/West Center	
			Up Design Load (psf)	Down Design Load (psf)	Up Design Load (psf)	Down Design Load (psf)
Jinko	JKMxxxM-72HL4-V	27.8	17.24	36.20	Not Tested	Not Tested
Canadian Solar	CS7N-xxxMB-AG	33.4	15.67	14.85	23.52	33.33

**NOTE:**

All installation configurations have achieved a minimum of 5psf design load in the downslope direction.

**ELECTRICAL BONDING & GROUNDING TEST MODULES:** This racking system may be used to ground and/or mount a PV module complying with UL1703 or UL61730 only when the specific module has been evaluated for grounding and/or mounting in compliance with the included instructions.

Manufacture	Module Model / Series
Aionrise	AION60G1, AION72G1
Aleo	P18 & P19 S18, S19, S59, & S79
Aptos Solar	DNA-108-(MF/BF)10-xxxW DNA-120-(MF/BF)10-xxxW DNA-120-(MF/BF)26 DNA-120-MF10 DNA-144-(MF/BF)26 DNA-144-BF10-xxxW-DG
Astronergy	ASM6612P Series CHSM6610(P/M)/HV CHSM6612(P/M)/HV CHSM72(P/M)-HC CHSM72M(DG)/F-BH
AU Optronics	PM Series
Auxin	AXN10Mxxx AXN6M610T AXN6M612T AXN6P610T AXN6P612T AXNG1M SERIES
Axitec	AC-xxx(M/P)/(60/72)(S/V) AC-xxxP/156-60S AC-xxxTGB/144TS AXIblackpremium X HC: AC-xxxMH/(120/144) (SB/VB) AXIblackpremium XL HC: AC-xxxMH/120(SB/VB) AXIpremium X HC: AC-xxxMH/(120/144)(S/V) AXIpremium XL HC: AC-xxxMH/120(S/V)
Bluesun Solar	BSMxxxM10-72HBD

Manufacture	Module Model / Series
Boviet Solar	BVM6610 & BVM6612 BVM6610M-xxxS-H-HC BVM6610M-xxxS-H-HC-BF BVM6612M-XXXS-H-HC-BF-DG BVM7612M-H-HC-BF-DG
BYD	P6K Series, MHK
Canadian Solar	CS1(K/H/U/Y)-MS, CS3(U/K)-MB-AG CS3K-(MB/MS/P/PB), CS3L-(P/MS) CS3N-MS, CS3U-(MB/MS/P/PB/PB-AG) CS3W-(MB-AG/MS/P/P-PB-AG) CS3Y-MB-AG, CS5A-M CS6.1-54TM-H, CS6.1-60TM-H CS6.1-72TB-H, CS7N-xxxTB-AG CS6.2-66TB-xxxH CS6K-(M/MS/P), CS6P-(M/P) CS6R-MS, CS6U-(M/P) CS6R-xxxMS-HL, CS7N-xxxMB-AG CS6V-M, CS6W-(MB-AG/MS) CS6W-xxx-TB-AG CS6X-P, CS7L-MB-AG, ELPs CS6(P/A)-MM CS7L-MB-AG, CS7L-TB-AG, CS7N-xxx MS CS7L-xxxMB-AG
Centrosolar America	C-Series & E-Series
CertainTeed	CTxxxMxx-(01/02/03/04) CTxxxPxx-01 CTM10400HC11-08, CTM10400HC11-09 CTM10400HC11-06, CTxxxHC11-06 CTTCxxxHC12-08
Eco Solargy	Orion 1000 & Apollo 1000
EMMVEE	Titanium Clear ExxxHCBT144-T
Energy America	ZLK-xxx

Manufacture	Module Model / Series
ET Solar	ETAC & ET Modules ET-M672BHxxxTW ET-M772BH520-550WW/WB ET-M772BHxxxTW/TB
Flextronics	FXS
Freedom Forever	FF-MP-BBB-xxx FF-MP1-BBB-xxx
FreeVolt	PVGraf
GCL	GCL-P6 & GCL-M6 Series
Hansol	TD-AN3, TD-AN4, UD-AN1 & UB-AN1
Hanwha SolarOne	HSL 60 & HSL 72
Heliene	36M, 60M, 60P, 72M & 72P Series 132HC M10 SL Monofacial 144HC M10 SL Bifacial 144HC M6 156HC M10 SL Bifacial
HT-SAAE	HT72-156(M/P) HT72-156P-C HT72-156P(V)-C HT60-156M-C HT60-156M(V)-C HT72-166M HT72-18X
Hyperion Solar	HY-DH108N8B HY-DH108P8(B) HY-DH144P8 HY-DH156N8 HY-DH156P8

- Unless otherwise noted, all modules listed above include all wattages and specific models within that series. Variable wattages are represented as "xxx"
- Items in parenthesis are those that may or may not be present in a compatible module's model ID
- Slashes "/" between one or more items indicates that either of those items may be the one that is present in a module's model ID

**ELECTRICAL BONDING & GROUNDING TEST MODULES:** This racking system may be used to ground and/or mount a PV module complying with UL1703 or UL61730 only when the specific module has been evaluated for grounding and/or mounting in compliance with the included instructions.

Manufacture	Module Model / Series
Hyundai	HiN-SxxxXG(BK)
	HiN-TxxxNF(BK)
	HiN-TxxxNI
	HiN-TxxxNJ
	HiN-TxxxOJ
	HiS-SxxxOJ
	HiS-SxxxXG(BK)
	HiS-SxxxYH(BK)
Hyundai Heavy Industries	MG, TG, RG, KG, MI, RI, KI, HI & TI Series
	HiA-SxxxHG, HiD-SxxxRG(BK), HiS-S400PI
Illuminate USA	IL5-72HBD-xxx M
	IL8-66HGD-xxx M
Imperial Star	ISM7-SHDD108-400/M
ITEK	iT, iT-HE & iT-SE Series
Japan Solar	JPS-60 & JPS-72 Series
JA Solar	JAM54S30 xxx/MR
	JAM54S31 xxx/MR
	JAM66D45 LB
	JAM72D10 xxx/MB
	JAM72D30MB
	JAM72D40 xxx/MB
	JAM72S30 /MR
	JAM72S30 /MR
	JAM78D10MB
	JAP6(k)-60-xxx/4BB
	JAP6-60, JAM6-60
	JAP6-72, JAM6-72

Manufacture	Module Model / Series
JA Solar (Cont.)	JAP60S##-xxx/** JAM6(k)-60-xxx/**, JAM60S##-xxx/** JAP6(k)-72-xxx/4BB, JAP72S##-xxx/** JAM6(k)-72-xxx/**, JAM72S##-xxx/** i. ##: 01, 02, 03, 09, 10 ii. **: SC, PR, BP, HiT, IB, MW, MR ** = Backsheet, ## Cell technology
	JK07(A/B) JKMSxxx(P/PP)-60 JKMSxxx(P/PP)-72 JKMSxxx-72 JKMSxxxM-60 JKMSxxxPP-60B-J4 JKMxxx(M/PP)-72-V JKMxxx(M/P/PP)-72 JKMxxx(P/PP)-60, JKMxxxPP-60(Plus) JKMxxx(P/PP)-72B JKMxxx-72L-V JKMxxxM-60 JKMxxxM-60(B/L/HL/BL/LV) JKMxxxM-60-V JKMxxxM-6RL3-B JKMxxxM-72HBL-V JKMxxxM-72HL(4)-V JKMxxxM-72HL4-TV JKMxxxM-72HLM-TV JKMxxxM-72L-V JKMxxxM-7RL3-TV JKMxxxM-7RL3-V JKMxxxN-54HL4-B JKMxxxN-72HL4-BDV JKMxxxN-72HL4-BDX JKMxxxN-72HL4-TV JKMxxxPP-60B JKMxxxPP-60B-J4 JKMxxxPP-72(Plus)
Jinko	JKMxxxM-60(B/L/HL/BL/LV) JKMxxxM-60-V JKMxxxM-6RL3-B JKMxxxM-72HBL-V JKMxxxM-72HL(4)-V JKMxxxM-72HL4-TV JKMxxxM-72HLM-TV JKMxxxM-72L-V JKMxxxM-7RL3-TV JKMxxxM-7RL3-V JKMxxxN-54HL4-B JKMxxxN-72HL4-BDV JKMxxxN-72HL4-BDX JKMxxxN-72HL4-TV JKMxxxPP-60B JKMxxxPP-60B-J4 JKMxxxPP-72(Plus)

Manufacture	Module Model / Series
Kyocera	KD-F Series
LA Solar	BLA Model LSxxxBF LSxxxBL LSxxxBL (410 watt) LSxxxHC LSxxxHC (430-450 watt range)
	LG Electronics
LONGi	LR4-60(HPB/HIB/HPH/HIH) LR4-72(HPH/HIH) LR4-72HBD xxxM LR5-54HAB-xxx M (fire type 29 only) LR5-54HPB-xxx M LR5-54HTB xxxM LR5-72HBD xxx M LR6-60, LR6-60(BK/PE/PB/PH/HPB/HIB/HPH/HIH) LR6-72, LR6-72(BK/HV/PE/PB/PH/HPH/HIH) LR7-72HGD-xxx M LR8-54HGBB LR8-66HGD-xxx M

- Unless otherwise noted, all modules listed above include all wattages and specific models within that series. Variable wattages are represented as "xxx"
- Items in parenthesis are those that may or may not be present in a compatible module's model ID
- Slashes "/" between one or more items indicates that either of those items may be the one that is present in a module's model ID

**ELECTRICAL BONDING & GROUNDING TEST MODULES:** This racking system may be used to ground and/or mount a PV module complying with UL1703 or UL61730 only when the specific module has been evaluated for grounding and/or mounting in compliance with the included instructions.

Manufacture	Module Model / Series
Maxeon	SPR-MAX3-xxx-BLK-R SPR-MAX3-xxx-COM SPR-MAX3-xxx-R SPR-MAX6-xxx SPR-MAX6-xxx-BLK
Meyer Burger	Meyer Burger Black Meyer Burger Glass Meyer Burger White
Mission Solar Energy	MSE MONO & MSE PERC MSExxx(SR8T/SR8K/SR9S/SX5T/SX5K/SX6W) MSExxxHT0B MSExxxSX6Z MSExxxSX9R MSH10-xxxHN4G MSH10-xxxHT4T MSI10-xxxHN4G MSI10-xxxHT4G MSI10-xxxHT4T MSN10xxxHT4T MSX10-xxxHN0B
Mitrex	Mxxx-L3H, Mxxx-I3H
Mitsubishi	MJE & MLE Series
mSolar	108BB HC Series (TXI10-xxx108BB) 144BB HC Series (TXS6-xxx144BB)
Neo Solar Power Co.	D6M Series
NE Solar	NESE xxx-60MH-M6 NESE xxx 66MHB-G12 NESE xxx-72MHB-M10 NESE xxx 72MHT-M10 NESE xxx 72THB-M10 NESE xxx 72MHB-M10

Manufacture	Module Model / Series
Panasonic	EVPVxxx EVPVxxx(H/K/PK/HK/HK2) VBHNxxxKA(01/02) VBHNxxxKA(03/04) VBHNxxxSA(15/16) VBHNxxxSA17(G/E) & SA18(E)
Peimar	SGxxxM (FB/BF), SMxxxM
Philadelphia Solar	PS-M108(HCBF)-400W (30 & 35mm frames) PS-M144(HCBF)-xxxW PS-MNB108(HCBF)-xxxW PS-MNB144(HCBF)-xxxW PS-MNB156(HCBF)-xxxW
Phono Solar	PSxxxM4(H)-24/TH
Phono Solar Tech.	Standard Modules
Prism Solar	P72 Series P72X-xxx
	B.LINE (PLUS/PRO) BFR G4.1 B.LINE PEAK DUO (G7/G7.2) B.LINE PEAK DUO L-(G5/G5.1/G5.2/G5.3) B.LINE PEAK DUO L-(G7/G7.1/G7.2/G7.3) B.LINE PLUS/PRO - L G4.x Q.PEAK DUO (BLK) G5 Q.PEAK DUO (BLK)-G6+ Q.PEAK DUO (BLK)-G7 Q.PEAK DUO (BLK) G8(+) Q.PEAK DUO (BLK) ML-G10,(a)(+) Q.PEAK DUO (BLK) ML G9(+) Q.PEAK DUO (G7/G7.2) Q.PEAK DUO BLK-G10(+) Q.PEAK DUO BLK G10+ /AC Q.PEAK DUO BLK-G6+/TS Q.PEAK DUO BLK ML-G10.B+

Manufacture	Module Model / Series
Q Cells	Q.PEAK DUO BLK ML-G10+ / t Q.PEAK DUO BLK ML-G10+ / TS Q.PEAK DUO BLK ML-G10.C+ Q.PEAK DUO G10+ Q.PEAK DUO L-(G5/G5.1/G5.2/G5.3) Q.PEAK DUO L-(G6/6.2/6.3) Q.PEAK DUO L-(G7/G7.1/G7.2/G7.3/G7.7) Q.PEAK DUO L-(G8/G8.1/G8.2/G8.3/G8.3 BFG) Q.PEAK DUO L-G6.3 / BFG Q.PEAK DUO ML-G12S.3 / BFG Q.PEAK DUO ML-G12S.d / BFG Q.PEAK DUO XL-(G10/G10.2/G10.3/G10.c/G10.d) Q.PEAK DUO XL-G10.3/BFG Q.PEAK DUO XL-(G11.2/G11.3) Q.PEAK DUO XL (G9/G9.2/G9.3) Q.PEAK DUO XL-G10.d/BFG Q.PEAK DUO XL-G11S Q.PEAK DUO XL-G11.3/BFG Q.PEAK DUO XL-G11S.3 / BFG Q.PEAK DUO XL-G9.3/BFG Q.PEAK DUO G10.C1+ AC Q.PEAK DUO BLK ML-G10.a+ Q.PLUS BFR G4.1(TAA/MAX) Q.PLUS L-G4.2/TAA Q.PLUS/PEAK/PRO - L G4.x Q. PLUS/PRO G3, Q.PLUS BFR G3.1, Q.PRO/PLUS G4  Q.PEAK DUO BLK ML-G10.XY+/AC (where "X" = any letter between A to W, where "Y" = any number between 1 to 9.)

- Unless otherwise noted, all modules listed above include all wattages and specific models within that series. Variable wattages are represented as "xxx"
- Items in parenthesis are those that may or may not be present in a compatible module's model ID
- Slashes "/" between one or more items indicates that either of those items may be the one that is present in a module's model ID

**ELECTRICAL BONDING & GROUNDING TEST MODULES:** This racking system may be used to ground and/or mount a PV module complying with UL1703 or UL61730 only when the specific module has been evaluated for grounding and/or mounting in compliance with the included instructions.

Manufacture	Module Model / Series
Q Cells (cont.)	Q.PRO BFR G4x, Q.PEAK (BLK) G4.1 (TAA/MAX) Q.PRO EC-G4.4 Q.PRO L-G2, Q.PEAK (BLK) (G3/G3.1) Q.TRON BLK M-G2+ Q.TRON BLK M-G2+ AC Q.TRON BLK M-G2.C+ Q.TRON BLK M-G2.F+ Q.TRON BLK M-G2.F1+/AC Q.TRON BLK M-G2.H+ Q.TRON BLK M-G2.H1+/AC Q.TRON BLK M-G2+ SERIES Q.TRON M-G2+ SERIES Q.TRON XL-G2.3/BFG
REC	PEAK & ECO RECxxxAA (BLK/Pure/Pure-R/ Pure-RX/ Pure 2/ Pro M) RECxxxNP (N-PEAK) RECxxxNP2 (Black) RECxxxNP3 Black RECxxxPE, RECxxxPE72 RECxxxTP RECxxxTP2(BLK2) RECxxxTP2S(B)(XV) RECxxxTP3M (Black) RECxxxTP4 (Black)
Renesola	60 Cell Modules & Vitrus2 RS6-xxxNBSG-E3
Risen	RSM110-8-xxxBMDG RSM144-6 RSM60-6 RSM72-6

Manufacture	Module Model / Series
SEG Solar	SEG-xxx-BMD-HV SEG-xxx-BMD-TB SEG-XXX-BMB-TB SEG-xxx-BMA-HV SEG-xxx-BMA-TB SEG-xxx-BMB-HV SEG-xxx-BMA-BG SEG-xxx-BMB-BG SEG-xxx-BTA-BG SEG-xxx-BTB-BG SEG-xxx-BMD-BG SEG-xxx-BTD-BG
S-Energy	SN72, SN60 Series SL45-60BG1/BHI SL45-60MBI-xxxZ
Seraphim	SEG-(6PA/6PB/6MA/6MA-HV/6MB/E01/E11) SRP-(6QA/6QB) SRP-320-375-BMB-HV SRP-390-405-BMD-HV SRP-390-415-BMA-HV SRP-xxx-6MB-HV, SRP-xxx-BMC-HV SRP-xxx-BTA-BG SRP-xxx-BTB-BG SRP-xxx-BTC-BG SRP-xxx-BTD-BG SRP-xxx-BTE-BG
Sharp	ND-24CQJ ND-25CQCS ND-F4Q300 ND-Q235F4 NU-SA NU-SC

Manufacture	Module Model / Series
Silfab	SLA-M/P, SLG-M/P SILxxx(BG/BK/BL/HC/HC+/HL/HM/HN/ML/NL/ NT/NX/NU/QD/QM) SIL-xxx XL SIL-xxx XM SIL-xxx XM+
Sirius	ELNSM54M-HC-BF Series ELNSM54M-HC Series
Solar4America	S4Axxx-108MH10BB S4Axxx-108MH10xxx S4Axxx-108TH10xxx S4Axxx-144MH10xxx S4Axxx-144TH10xxx S4Axxx-72MH5BB
SolarEver USA	SE-166*83-xxxM-120N SE-182*91-xxxM-108N SE-182*105-xxxM-96-BD
Solaria	PowerXTxxxR-PD/BD/AC PowerXTxxxC PowerXT-xxxR-PM (AC) PowerX-400R
SolarTech	STU HJT & STU PERC
SolarWorld	Sunmodule Protect/Plus
Sonali	SS-M-360 to 390 Series SS-M-390 to 400 Series SS-M-440 to 460 Series SS-M-430 to 460 BiFacial Series
Sun Edison/ Flextronics	F-Series / FLEX FXS, R-Series / FLEX FXS
Suniva	Optimus Series, MV Series
Sunmac Solar	M754SH-BB Series

- Unless otherwise noted, all modules listed above include all wattages and specific models within that series. Variable wattages are represented as "xxx"
- Items in parenthesis are those that may or may not be present in a compatible module's model ID
- Slashes "/" between one or more items indicates that either of those items may be the one that is present in a module's model ID

**ELECTRICAL BONDING & GROUNDING TEST MODULES:** This racking system may be used to ground and/or mount a PV module complying with UL1703 or UL61730 only when the specific module has been evaluated for grounding and/or mounting in compliance with the included instructions.

Manufacture	Module Model / Series
SunPower	X-Series 72 & E-Series 72 X-Series 96 & E-Series 96 P-Series, Sig Black SPR E20 435 COM (G4 Frame) Axxx-BLK-G-AC, SPR-Mxxx-H-AC SPR-Mxxx-BLK-H-AC
SunPro	SPDGxxx-120M12
SunTech	STP XXX, STPXXXS - B60/Wnhb
Talesun	TP572, TP596, TP654, TP660 TP672, Hipor M, Smart TD6172M TD7G72M TM3G48M TM3G54M TM3G66M TM7G54M TM7G60M TM7G72M TP6F72M TP6F72M(H) TP7G54M(H)
Tesla	TxxxS, TxxxH
Thornova	TS-BBT54(xxx) TS-BG54 TS-BG72 TS-BGT72(xxx)
Trina	DE06, DE09.05, DE09C.07 DE18M(II), DEG18MC.20(II) DE19, DEG19C.20, TSM-NE09RC.05 DEG15HC.20(II), DEG15MC.20(II), DEG15VC.20(II) PA05, PD05, DD05, DD06 PD14, PE14, DD14, DE14, DE15, DE15V(II)

Manufacture	Module Model / Series
Trina ( Cont.)	TSM-DE06X.05(II) TSM-DE09.05 TSM-DE09.08 TSM-DE09C.07 TSM-DEG21C.20 TSM-NE09RH.05 TSM-NE19RC TSM-NEG19RC.20 TSM-NEG21C.20
Universal Solar	UNI4xx-144BMH-DG UNI5xx-144BMH-DG UNIxxx-108M-BB UNIxxx-120M-BB UNIxxx-120MH
Upsolar	UP-Mxxx
URE	D7K_H8A, D7M_(H7A/H8A) FAKxxx(C8G/E8G), FAMxxxE7G-BB FAMxxxE8G(-BB), FBKxxxM8G
URECO	F6MxxxE7G-BB FBMxxxM7G-BB FBMxxxMFG-BB
Vikram Solar	Eldorado, Solivo & Somera PREXOS VSMDHT.60.AAA.05 PREXOS VSMDHT.72.AAA.05 Paradea VSMDH.72.AAA.05 Paradea VSMDH.66.AAA.05
VSUN	VSUN400-415-144BMH VSUN4xx-144BMH-DG VSUN5xx-144BMH-DG VSUNxxx-108BMH VSUNxxx-108M-BB

Manufacture	Module Model / Series
VSUN (Cont.)	VSUNxxx-108MH VSUNxxx-120BMH VSUNxxx-120M-BB VSUNxxx-132BMH VSUNxxx-144M-BB VSUNxxx-60M-BB VSUNxxx-72MH VSUNxxxN-108BMH-BB VSUNxxxN-108BMH-BB (SoftPaw) VSUNxxxN-120BMH-BB (SoftPaw) VSUNxxxN-144BMH VSUNxxxN-144MH VSUNxxx-144BMH VSUNxxx-144MH VSUNxxx-144M-BW
Waaree	Arka Series WSMDi
Winaico	WST & WSP Series
Yingli	YGE 60 Cell YGE 60 Cell Series 2 YLM 60 YLM 72 YLM-VG
Yotta Energy	YSM-B450-1
ZNShine Solar	ZXM6-72 Series, ZXM6-NH144 ZXM6-NH120 Series ZXM6-NHLDD144-XXX/M ZXM7-SH108 Series ZXM7-SHDB144 ZXM7-SHLDD144 ZXM7-UHLDD144 ZXM8-GPLDD132 Series ZXM8-TPLDD132

- Unless otherwise noted, all modules listed above include all wattages and specific models within that series. Variable wattages are represented as "xxx"
- Items in parenthesis are those that may or may not be present in a compatible module's model ID
- Slashes "/" between one or more items indicates that either of those items may be the one that is present in a module's model ID