

GRIDFLEX[™] 10 INSTALLATION GUIDE



 UNIRAC[®]

UNIRAC Code-Compliant Installation Manual

© 2024 by Unirac, Inc. All rights reserved.



GRIDFLEX[™] 10 INSTALLATION GUIDE

TABLE OF CONTENTS

TOOLS AND SPECIFICATIONS.....	1
SYSTEM COMPONENTS.....	2-5
INSTALLATION STEPS.....	6-17
MODULE REPLACEMENT.....	18
WIRE MANAGEMENT.....	19
BONDING AND GROUNDING.....	20-21
FIRE CODE COMPLIANCE.....	22
CODE COMPLIANCE NOTES.....	23
MECHANICAL LOAD TESTING.....	24
COMPATIBLE MODULES.....	25-30

TECHNICAL SPECIFICATIONS:

Maximum System Voltage: 1500V

Allowable Module Length Dimensions: 71" to 100"

Allowable Module Width Dimensions: 39" to 52"

Hardware: Stainless steel

TOOLS REQUIRED OR RECOMMEND FOR LAYOUT, ATTACHMENTS, AND INSTALLATION:

- Drill (Do Not Use an Impact Driver)
- 3/8" Socket
- Torque Wrench
- Tape Measure
- Chalk Reel
- Optional L1 and L2 Span Spacers

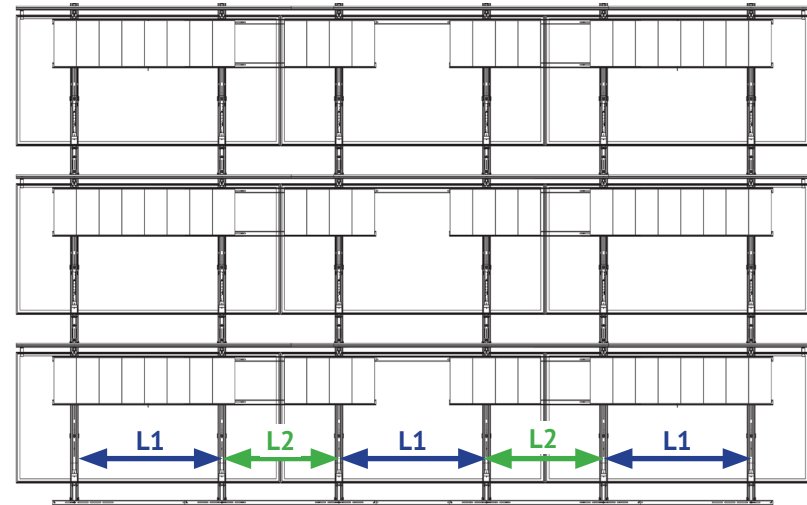

- *Refer to construction drawing for L1 and L2 spans.*
- *L1 and L2 spans are measured from rail center to rail center*

IMPORTANT

All applicable OSHA safety guidelines should be observed when working on a PV installation job site. The installation and handling of PV solar modules, electrical installation and PV racking systems involves handling components with potentially sharp metal edges. Rules regarding the use of gloves and other personal protective equipment should be observed.

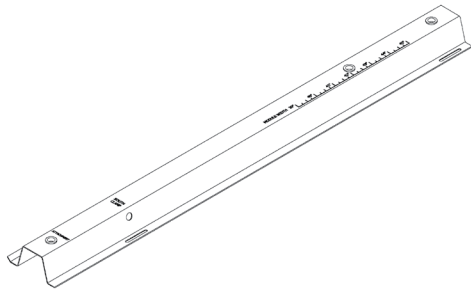

SOUTH RAIL (P/N: 380012/380022)

The rail is made of structural steel, pre-assembled with 1/4" SS Riv-Hex nuts. Module width scale is marked on rail, for overlap alignment.

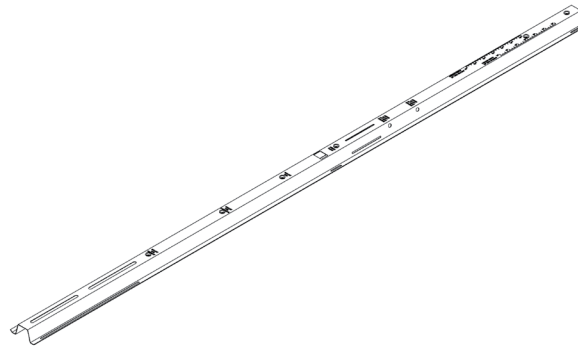

MID RAIL (P/N: 380100/380110/380120/380130)

The rail is made of structural steel, pre-assembled with 1/4" Riv-Hex nuts, SS.

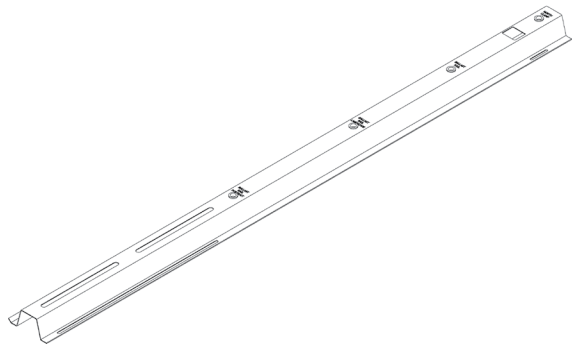

NORTH RAIL (P/N: 380200)

The rail is made of structural steel, pre-assembled with 1/4" Riv-Hex nut, SS.

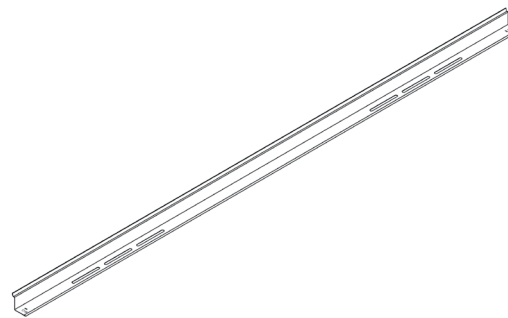

BALLAST RAILS (P/N: 380300)

Ballast Rails are made of structural steel and hold standard ballast blocks.

NOTE:

Mid rails have a provision to adjust the row to row spacing (10" or 13"). Two module-width scales, each corresponding 10" and 13" row spacing are printed on rail, so that rails are overlapped to achieve accurate module width connection.

BALLAST TRAY NOTE:

Ballast rails can fit up to 4 standard 4"x8"x16" solid concrete cap blocks in landscape and 8 blocks in portrait. If more than 6 blocks are required, additional rails will be placed over the initially laid rails on both sides.

HARDWARE:

1. 1/4"-20 X 0.75" Hex Head Bolt
2. 5/16" Flat Washer, 1" OD, .125 Thick

P/N stands for Part Number

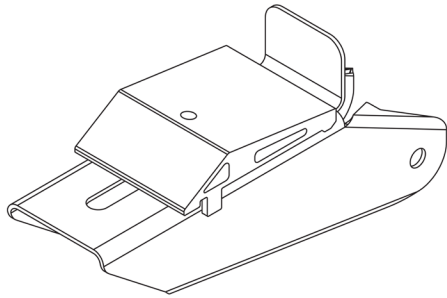

SOUTH CLAMP (P/N: 380701)

The south clamp assembly is made of a structural steel and engages the return flange underneath the module to secure the module.

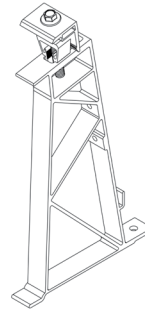

NORTH STANCHION (P/N: 380601)

The north stanchion assembly is made of a mill finish Aluminum and secures the module.

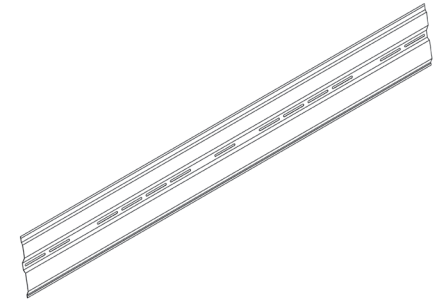

WIND DEFLECTORS

(P/N: 380400/ 380410/380420/ 380430/ 380440/ 380450/380401 380402)

Wind deflectors are made of steel. Multiple lengths are available to accommodate different module lengths

IMPORTANT: WIND DEFLECTORS ARE REQUIRED ON ALL MODULES

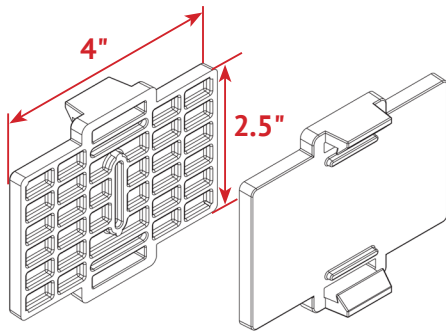

CLIP-ON ROOF PAD (P/N: 380802)

Roof Pad provides a protective interface between the rails and roofing material to protect the roof membrane.

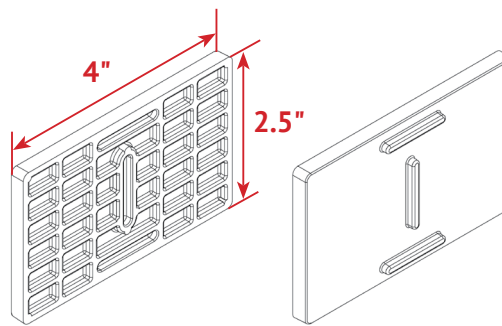

ROOF PAD STACK (P/N: 380800)

Roof Pad Stack is placed beneath the Clip-on-Roof Pad to level the array at uneven surfaces.

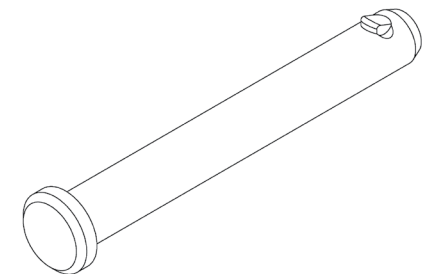

CLEVIS PIN (P/N: M31216)

Clevis pin is made of mill finish Aluminum with a self-locking Stainless Steel wedge pin to secure the south clamp to the base rail.

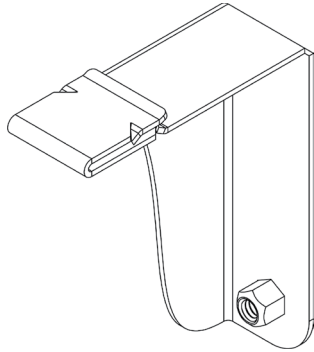

WIND DEFLECTOR BRACKET (P/N: 380405)
The wind deflector end bracket is made of steel and reinforces the cantilever of the wind deflector.

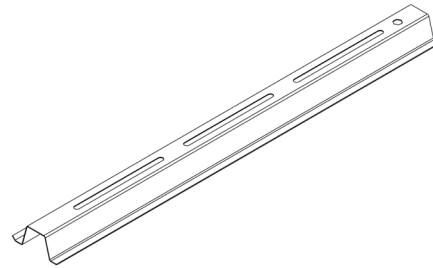

SOUTH RAIL STIFFENER (P/N: 380050/380051)
The south rail stiffener is made of steel and reinforces the mid rail to south rail connection.

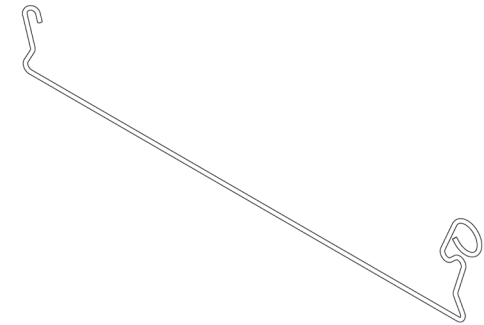

BALLAST RAIL BRACE (P/N: 380301)
The ballast rail brace is made out of stainless steel and reinforces the ballast rails in the L1 spacing with high ballast counts.

WIRE MANAGEMENT ACCESSORIES (OPTIONAL)

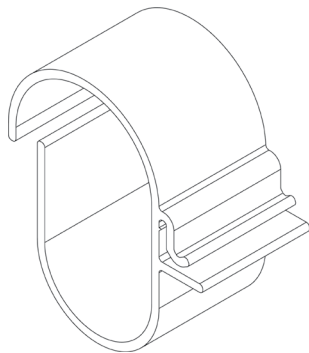

WIRE MANAGEMENT CLIP, (P/N: 380900)
The wire management clip is made of PVC plastic and is used to route wires in the east-west direction along the ballast rail

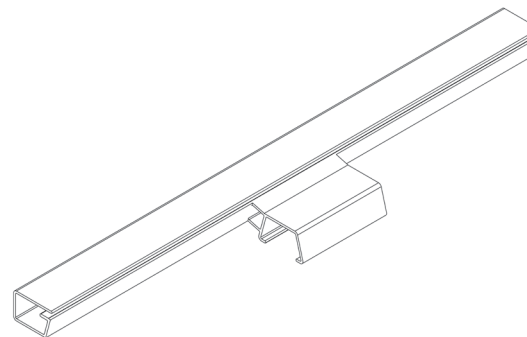

INTER-ROW WIRE MANAGEMENT COVER (P/N: 380910/ 380950)
The inter-row wire management cover is made of PVC plastic and is used to route and protect wires running north-south direction between module rows.

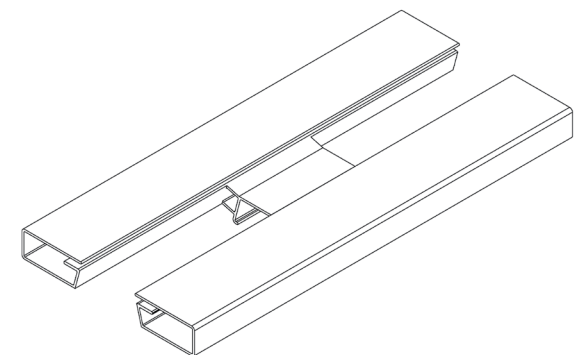

HOMERUN WIRE MANAGEMENT COVER (P/N: 380920/ 380940)
The homerun wire management cover is made of PVC plastic and is used to route and protect homerun bundles running north-south direction between modules rows.

Made in USA Components Part Number Data

PART NUMBER	DESCRIPTION
380300-US	GF10 BALLAST RAIL
380100-US	GF10 MR, MW 39-45", RS 10/13"
380120-US	GF10 MR, MW 39-45", RS 17"
380110-US	GF10 MR, MW 45-52", RS 10/13"
380130-US	GF10 MR, MW 45-52", RS 17"
380200-US	GF10 NR
380012-US	GF10 SR, MW 39-45"
380022-US	GF10 SR, MW 45-52"
380400-US	GF10 WIND DEFLECTOR <69"
380401-US	GF10 WIND DEFLECTOR 69-73"
380402-US	GF10 WIND DEFLECTOR 73-77"
380410-US	GF10 WIND DEFLECTOR 77-82"
380420-US	GF10 WIND DEFLECTOR 82-87"
380430-US	GF10 WIND DEFLECTOR 87-92"
380440-US	GF10 WIND DEFLECTOR 92-97"
380450-US	GF10 WIND DEFLECTOR 97-100"
380802-US	CLIP-ON ROOF PAD
380800-US	ROOF PAD STACK
380301-US	GF10 BALLAST RAIL BRACE
380050-US	GF10 RAIL STIFFENER, MW 39-45"
380051-US	GF10 RAIL STIFFENER, MW 45-52"

INSTALL ROOF PADS ON RAILS

Attach roof pads to all pre-punched slots in rails. Install a roof pad under every north stanchion, rail overlap, and south clamp located at the south edge of the array.



Ensure there is no direct contact between metal parts and the roof membrane to prevent damage and potential leaks.

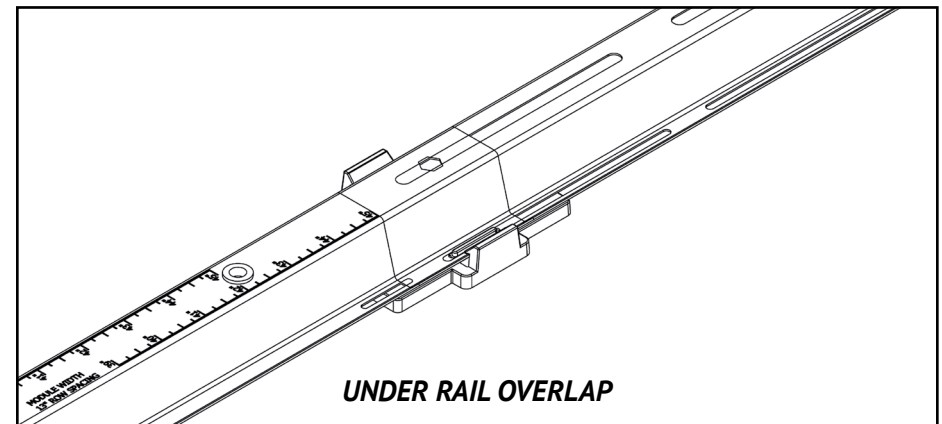
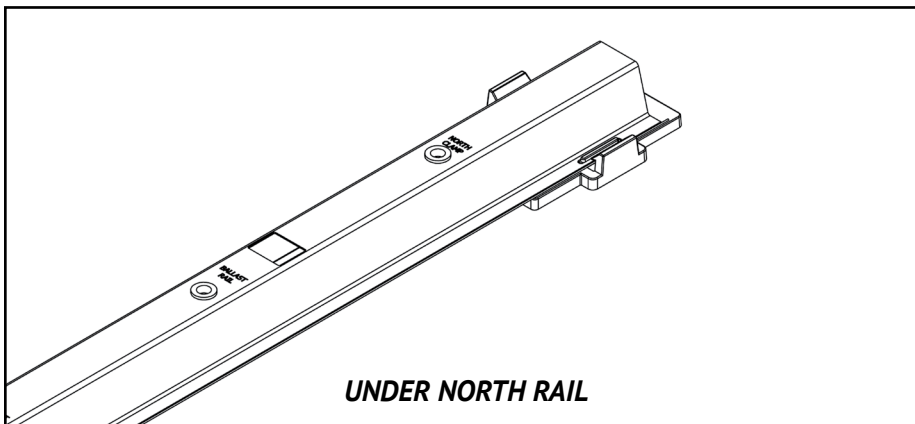
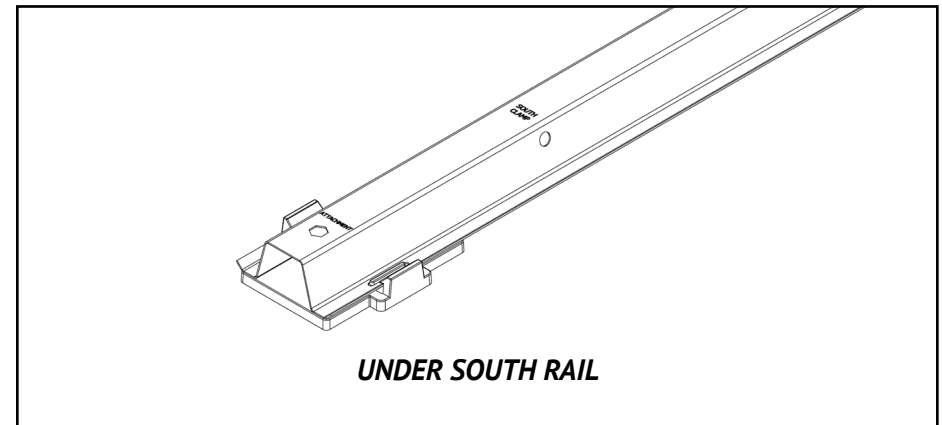
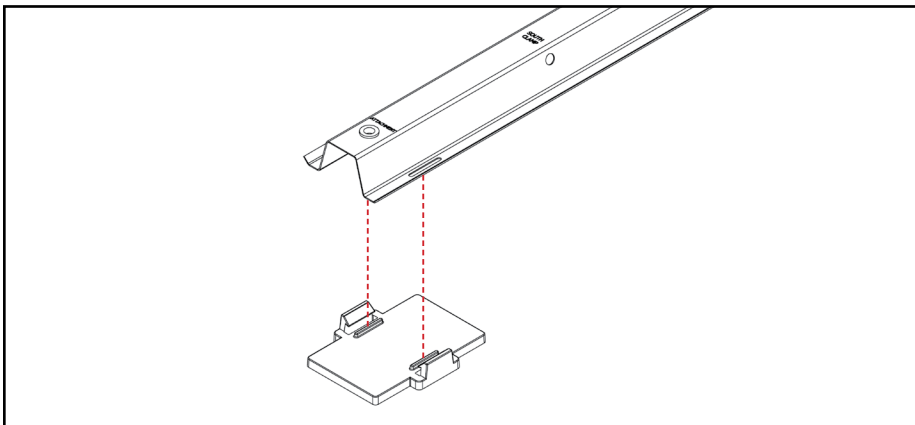

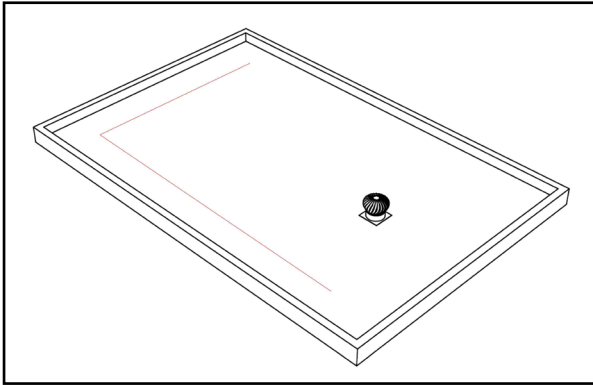

STEP 1: MARK ARRAY LAYOUT ON ROOF:
Use chalk line to mark distances from roof edge as called out in construction documents.

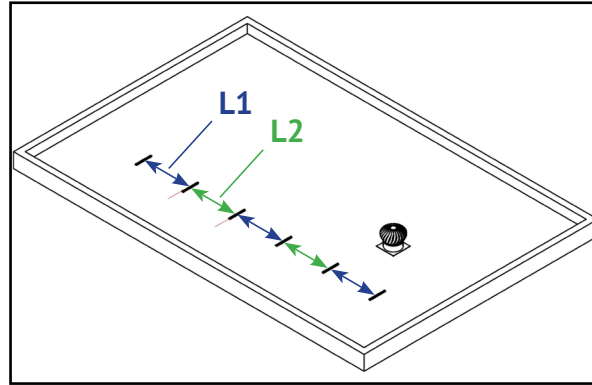

STEP 2: LOCATE ARRAY ON ROOF:
Place south rails on previous chalk lines. Follow L1 & L2 rail spans as per construction documents.

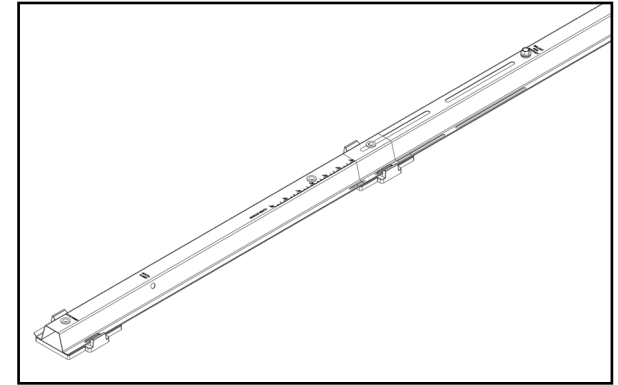

STEP 3: ATTACH MID RAIL TO SOUTH RAIL:
Overlap Mid-Rails on top of South Rails, use the measurement scale printed on the rail to determine the overlap length. Match the value on scale to the module width.

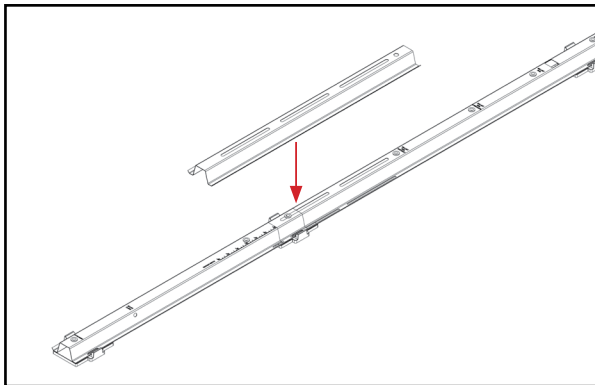

STEP 3: ATTACH MID RAIL TO SOUTH RAIL (CONT.):
Place the stiffener over both the mid and south rails, ensuring the hole in the stiffener aligns with the hole in the mid rail labeled 'Ballast Rail Portrait'.

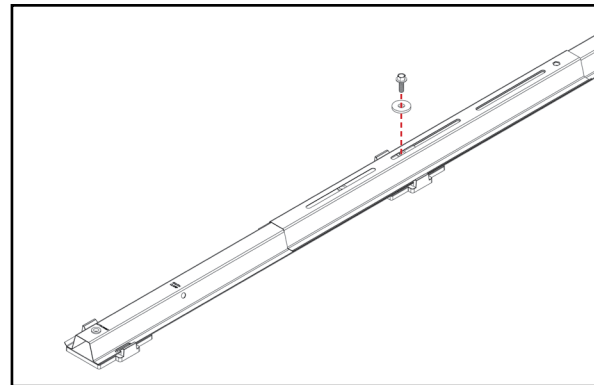

STEP 3: ATTACH MID RAIL TO SOUTH RAIL (CONT.):
Insert a $\frac{1}{4}$ -20 hex bolt with a flat washer through the slot in the stiffener and into the riv-nut on the south rail.

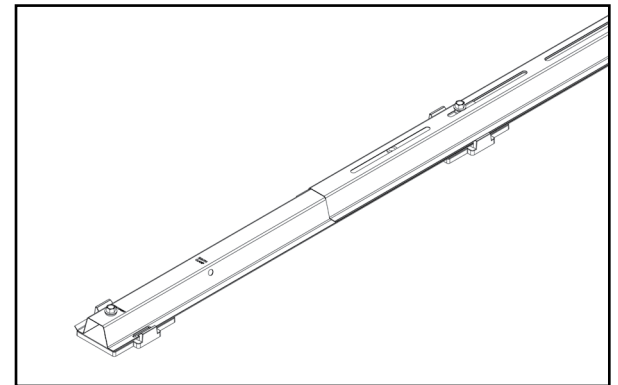

STEP 3: ATTACH MID RAIL TO SOUTH RAIL (CONT.):
Torque $\frac{1}{4}$ -20 hex bolt to 12 ft-lbs
NOTE: Stiffener is not needed for base rails with mechanical attachments

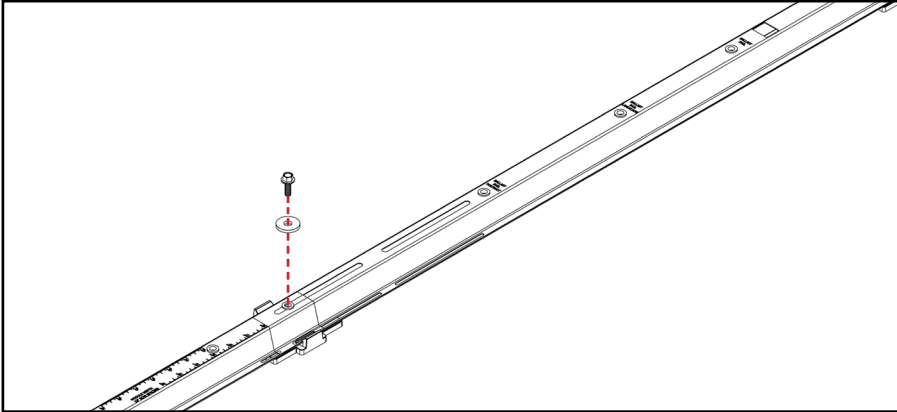

STEP 4: ATTACH MID-RAIL TO MID-RAIL/ MID-RAIL TO NORTH-RAIL :

Overlap next rail (Mid or North) on top of rail laid on roof, use the measurement scale (**10", 13" or 17" row spacing**) printed on the rail to determine the overlap length. Match the value on scale to the module width. Insert $\frac{1}{4}$ -20 hex bolt with flat washer into riv-nut and secure the rails.

Torque value – 12 ft-lbs

NOTE: In STEP 3 and STEP 4

- If two riv-nuts are showing in the rail slots, secure the rails to the riv-nut that is closer to the North side.
- For modules that do not measure to $\frac{1}{4}$ " increments, round down to the next $\frac{1}{4}$ " mark.

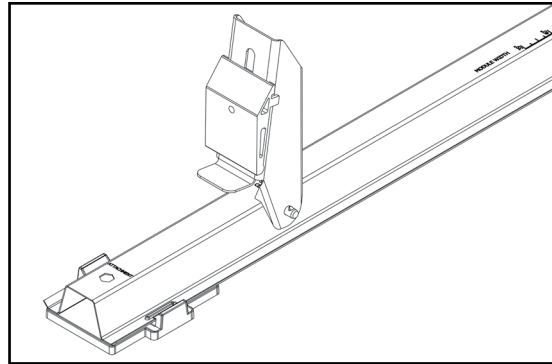
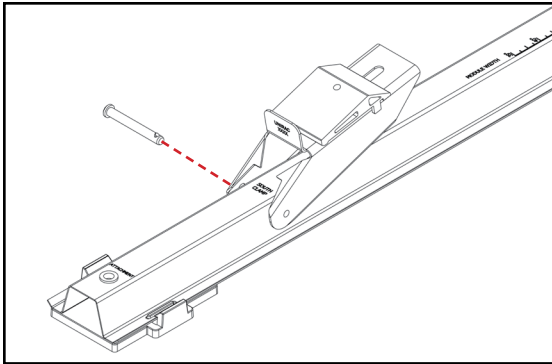

STEP 5: ATTACH SOUTH CLAMP

- Place the south clamp at the specified location on the base rail.
- Align holes in the south clamp with the side holes of rail and insert a clevis pin (from either direction).
- Rotate the south clamp to vertical.

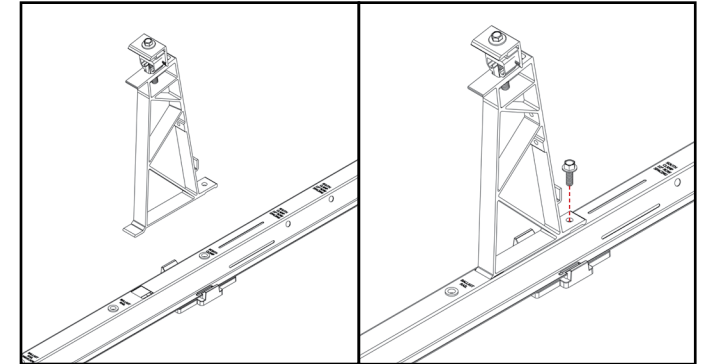

STEP 6: ATTACH NORTH CLAMP:

- Insert the front tab of the North Clamp into the slot on the base rail at the specified location.
- Secure with a 1/4-20 hex head bolt through the rear hole into the riv-nut

Torque value – 12 ft-lbs

CAUTION

Ensure Clevis Pin is fully inserted.

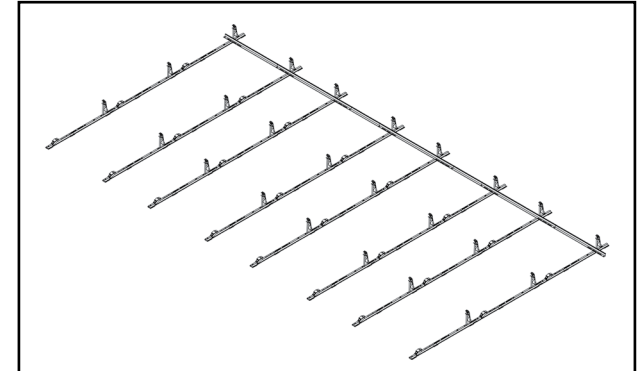
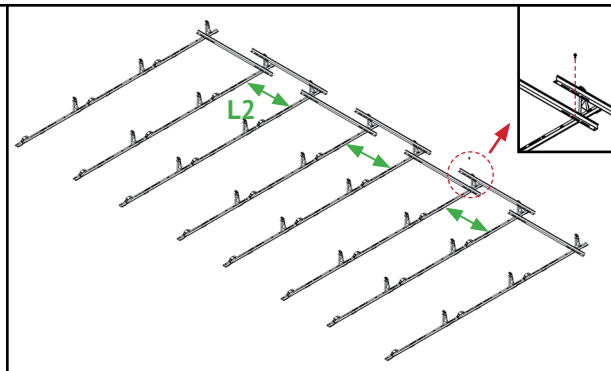
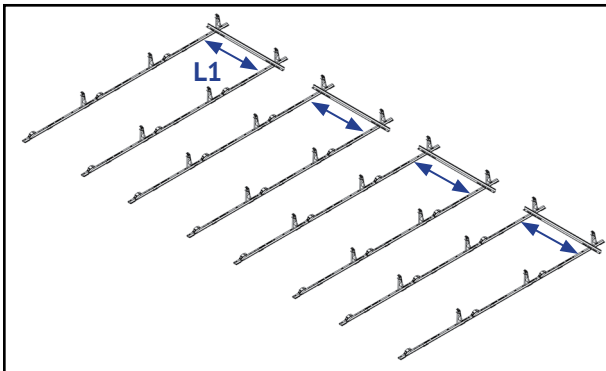

STEP 7: BALLAST RAILS INSTALLATION (NORTH-SIDE OF BALLAST BLOCK):

- Place the ballast rails at L1 span locations.
- Then place the ballast rails at L2 span locations.
- Align the slots in the ballast rails with the holes on the base rail.

BALLAST RAILS INSTALLATION

(NORTH-SIDE OF BALLAST BLOCK)(CONT.):

- Secure the ballast rails with a 1/4-20 hex head bolt to rails.

Torque value – 12 ft-lbs

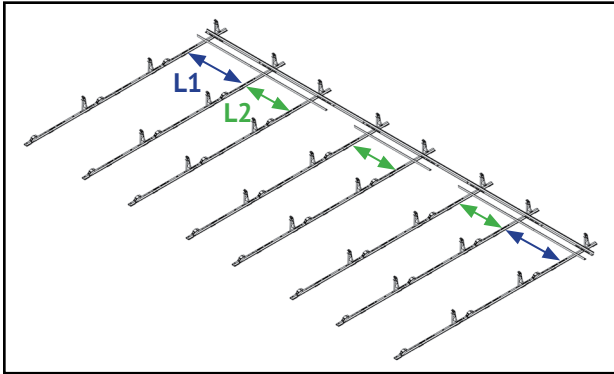

STEP 8: BALLAST RAILS INSTALLATION (SOUTH-SIDE OF BALLAST BLOCK):

- Place the ballast rails at L1 span locations on the east and west edges and continue placing them at L2 span locations.
- Secure the ballast rail to the mid/north rails with a 1/4-20 hex head bolt at a specified location to place ballast blocks in portrait or landscape orientation.

Torque value – 12 ft-lbs

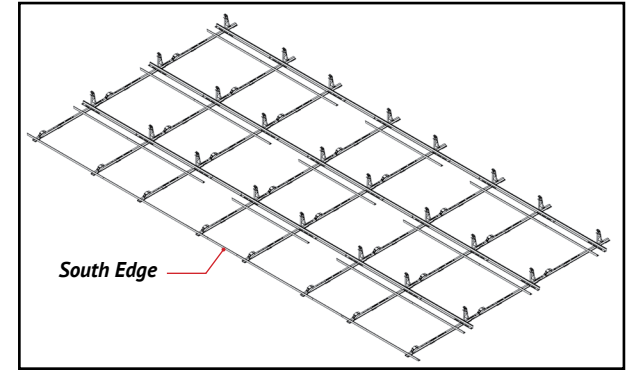
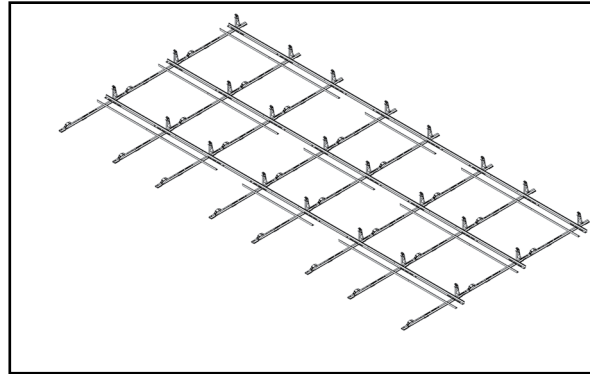

STEP 9: BALLAST RAILS INSTALLATION

(SOUTH EDGE OF ARRAY):

- Follow **STEP 7** to install ballast rails on the south edge of the array.

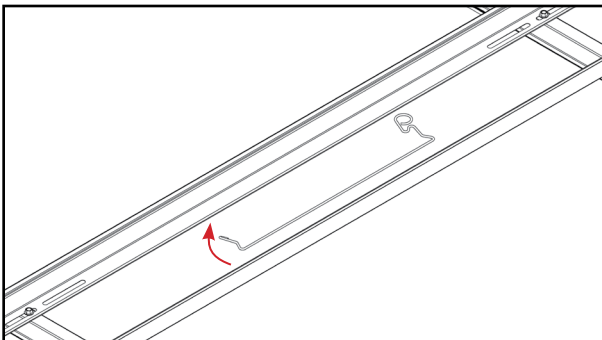

STEP 10: BALLAST RAIL BRACE INSTALLATION

- Place the rail brace between ballast rails and rotate it.
- Ensure rail brace is centered between base rails of L1 spacing.

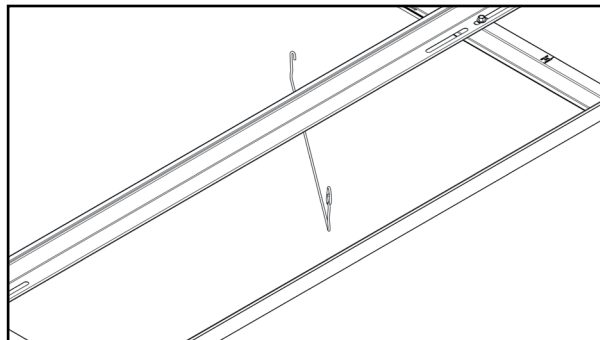

STEP 10: BALLAST RAIL BRACE INSTALLATION (CONT.)

- Hold the rail brace upright as shown in the figure above.

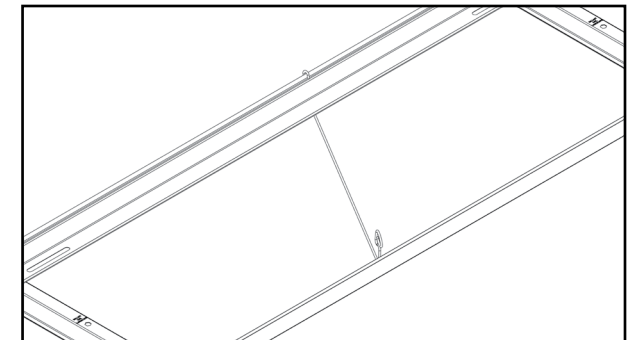

STEP 10: BALLAST RAIL BRACE INSTALLATION (CONT.)

- Hook the end of the rail brace without the loop onto the top of the ballast rail.

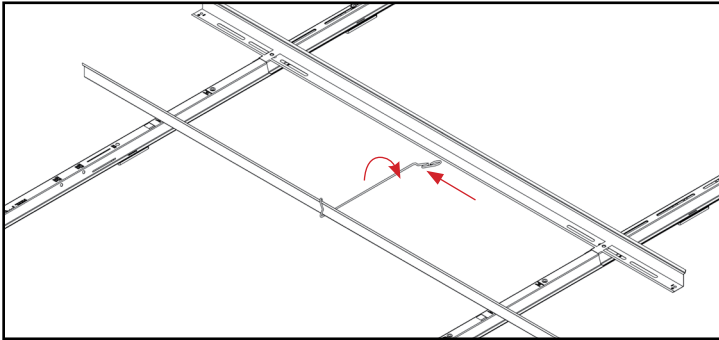

STEP 10: BALLAST RAIL BRACE INSTALLATION (CONT.)

- Twist the other end of the rail brace and slide it under the ballast rail to make the rail brace perpendicular to ballast rails.

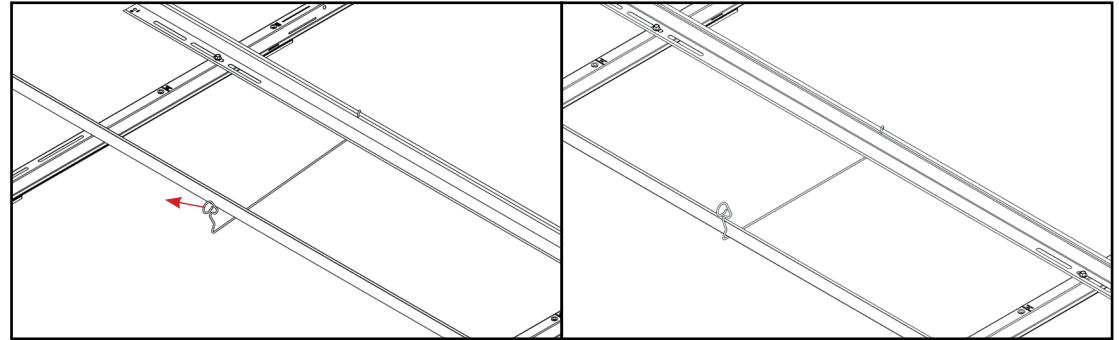

STEP 10: BALLAST RAIL BRACE INSTALLATION (CONT.)

- Pull the ring on the rail brace until it clicks onto the rail.

NOTE: Refer to construction drawings for doubling the ballast rails and ballast rail braces.

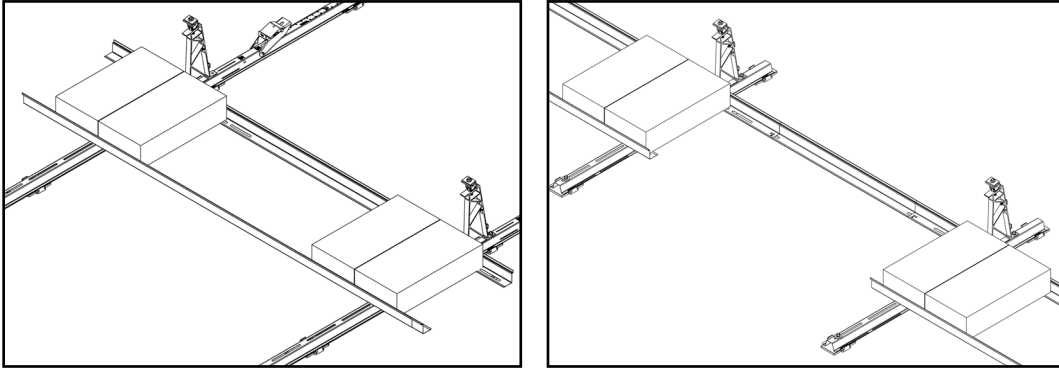

STEP 11: LAY BALLAST BLOCKS:

- Lay ballast blocks into ballast rails and quantity of blocks to be placed should be as per engineering report or U-Builder report.
- Ballast block placement for a given number of blocks - See pages **13 & 14**

BALLAST BLOCKS CONFIGURATIONS AT EAST -WEST EDGES

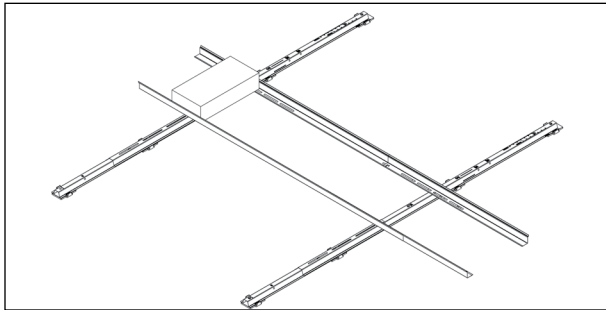

1-Block Configuration

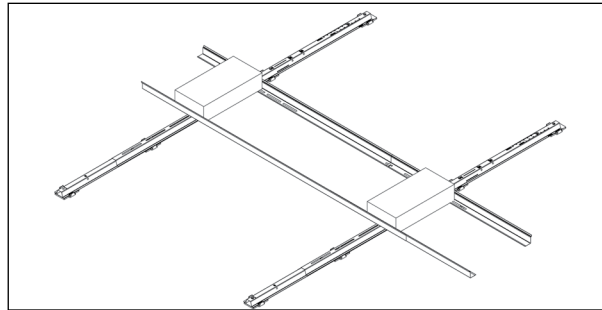

2-Block Configuration

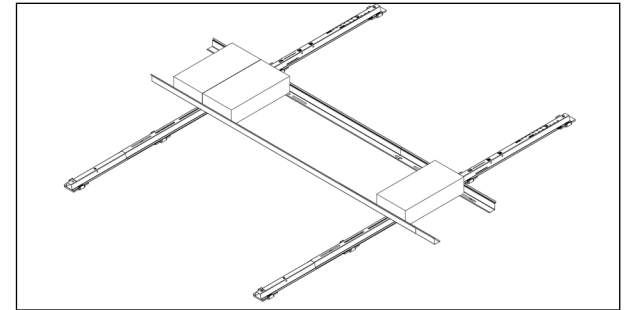

3-Block Configuration

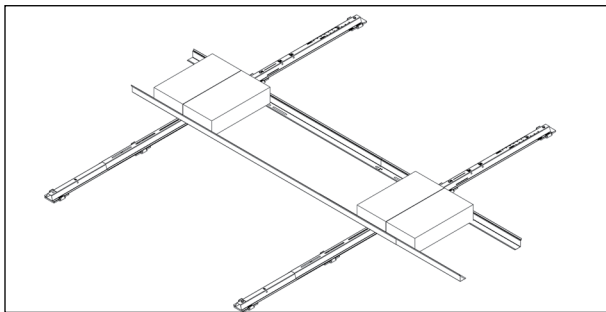

4-Block Configuration

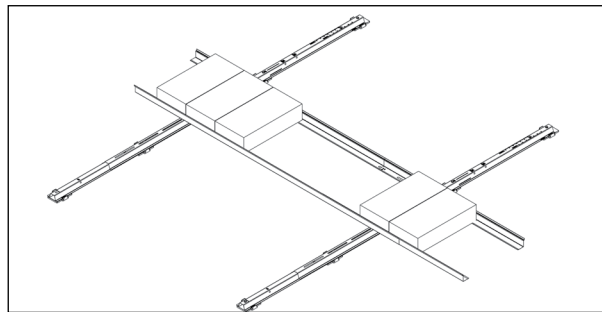

5-Block Configuration

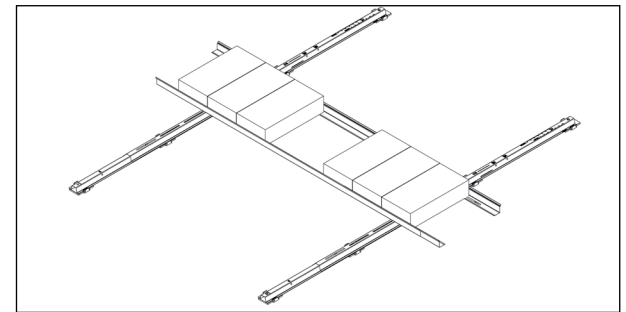

6-Block Configuration

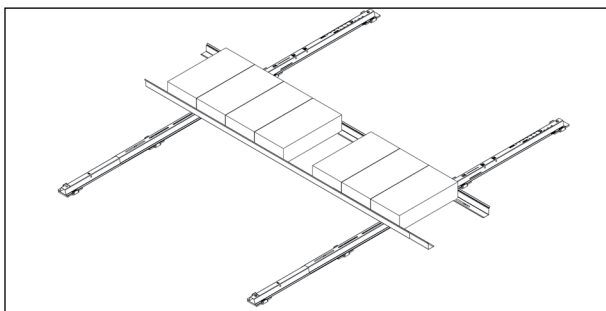

7-Block Configuration

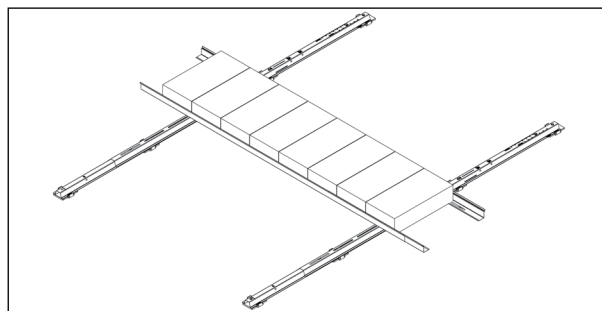

8-Block Configuration

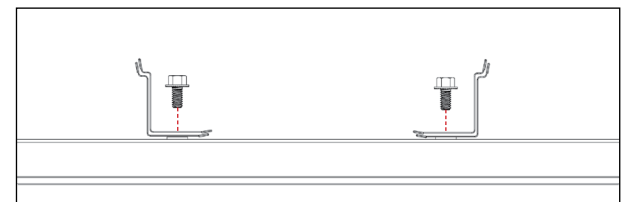

NOTE:
Ballast blocks are concentrated around the base rails. For an odd number of ballast blocks, place higher number of ballast blocks closer to array edge.

BALLAST BLOCKS CONFIGURATIONS AT L2 SPANS

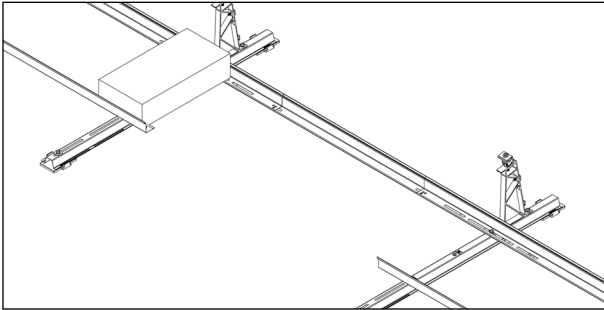

1-Block Configuration

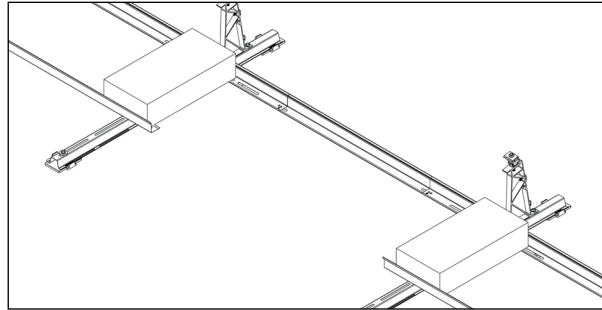

2-Block Configuration

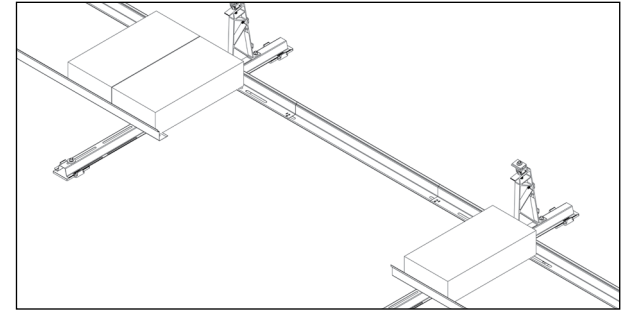

3-Block Configuration

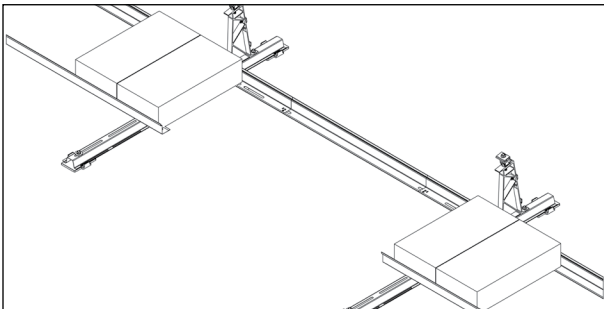

4-Block Configuration

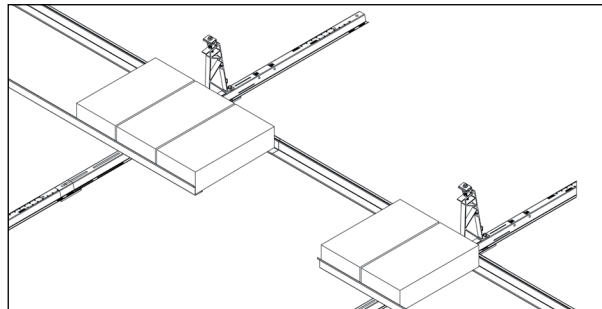

5-Block Configuration

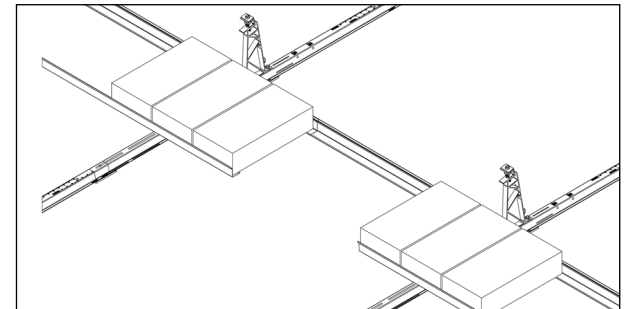

6-Block Configuration

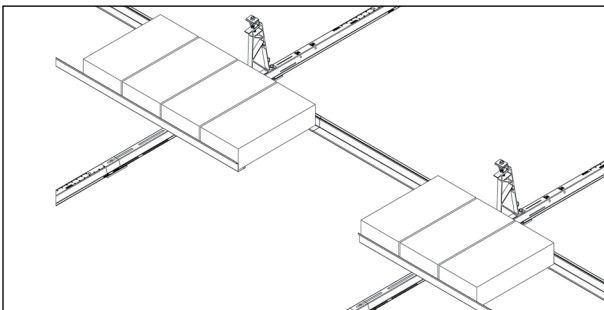

7-Block Configuration

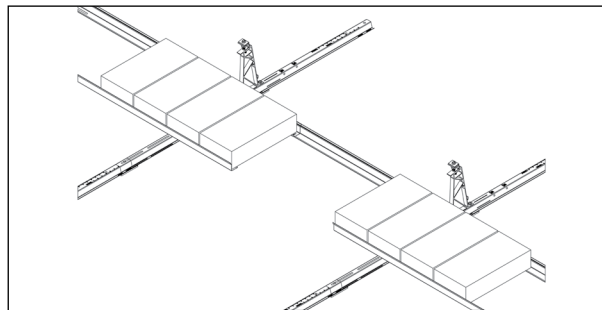

8-Block Configuration

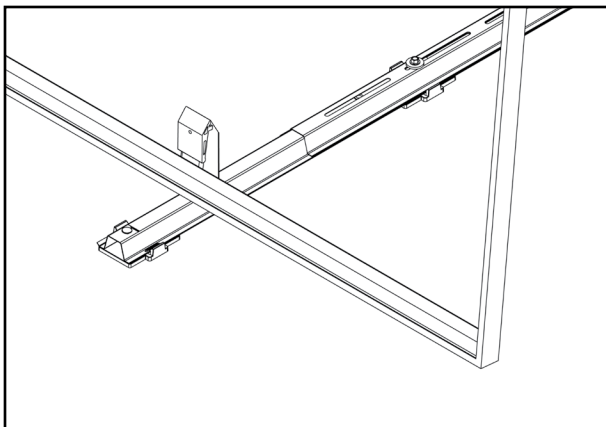

STEP 12:
Place module at South Clamps.

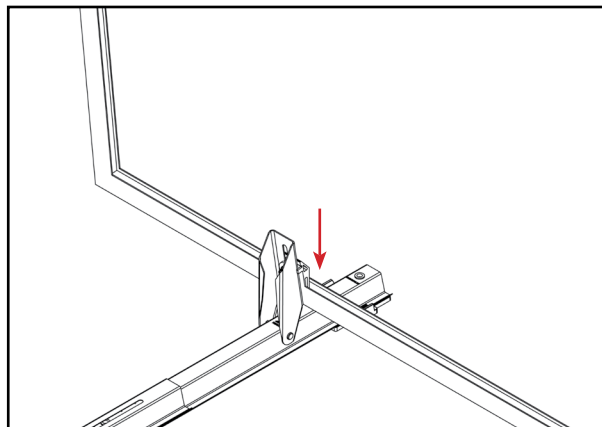

STEP 13:
Push sliders down to fully engage module flange and tighten the bolt.
Torque the bolt to 12 ft lbs

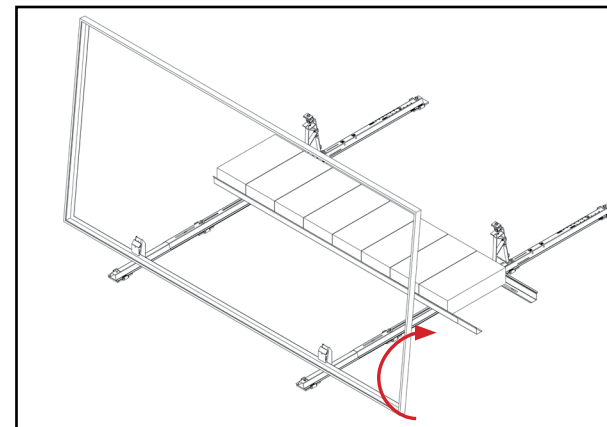

STEP 14:
Rotate the module downward and position it on the north stanchions.

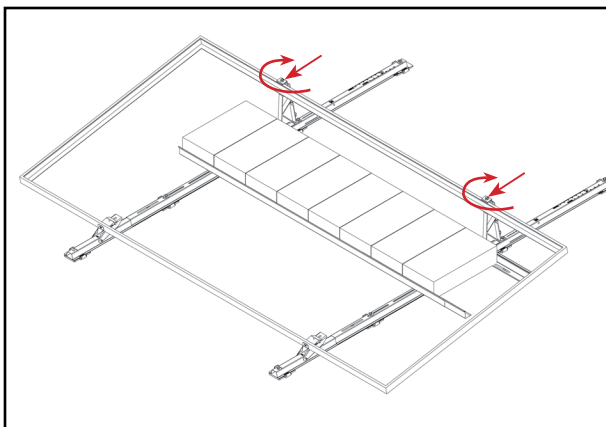

STEP 15:
Slide the north clamps onto the module and tighten the bolts.
Torque the bolt to 12 ft-lbs.
Complete modules installation by repeating STEP 12 to STEP 15.

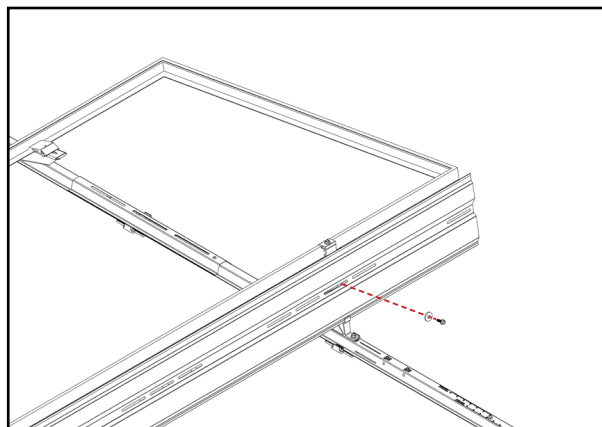

STEP 16: INSTALL WIND DEFLECTOR

- Position the wind deflector in the V-projection of the north stanchion.
- Align the wind deflector with the module end and slots of the north stanchion holes.

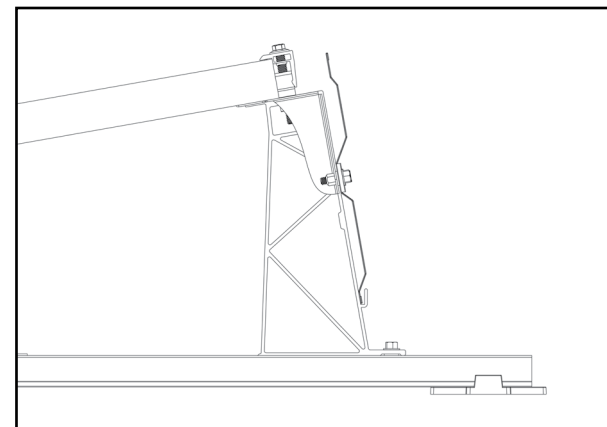

STEP 17:
Secure wind deflector to north stanchion with a 1/4-20 hex head bolt and washer.
Torque the bolt to 12 ft-lbs.

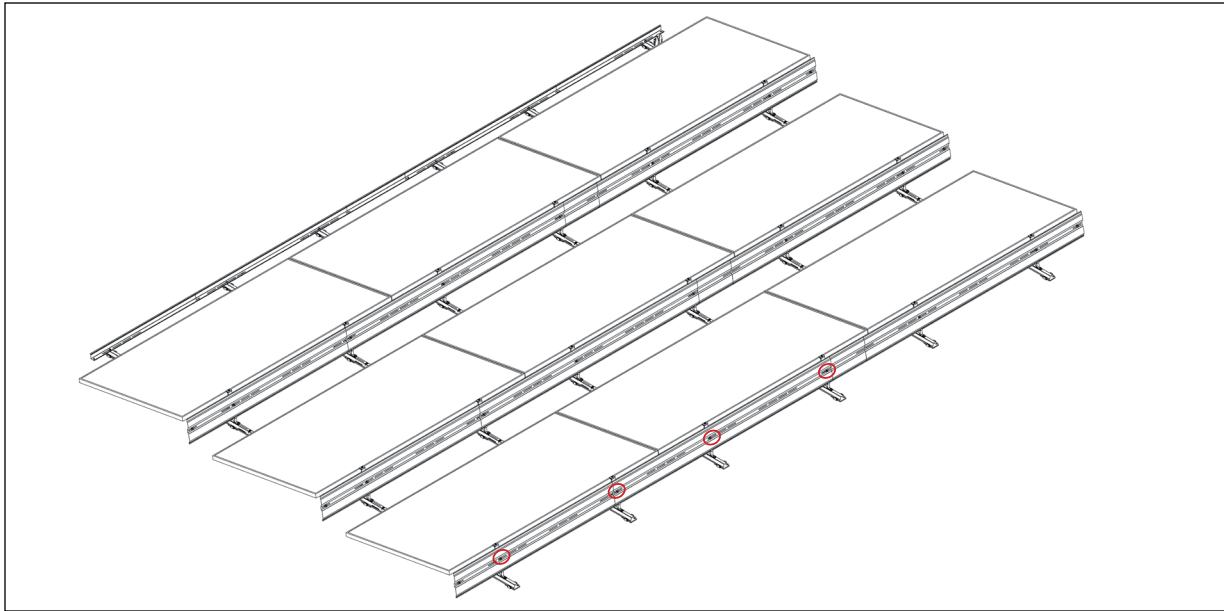

CAUTION

Ensure that each wind deflector is attached to three north stanchions, while the east and west edge wind deflectors are attached to only two north stanchions.

CAUTION

Once the modules are in place, wind deflectors must be installed to ensure the system maintains optimal performance at anticipated wind speeds.

STEP 18: WIND DEFLECTOR BRACKET INSTALLATION

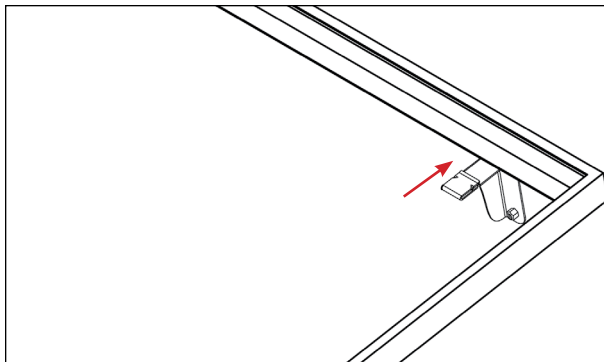

Position the bracket beneath the module and pull it to engage with the module's return flange.

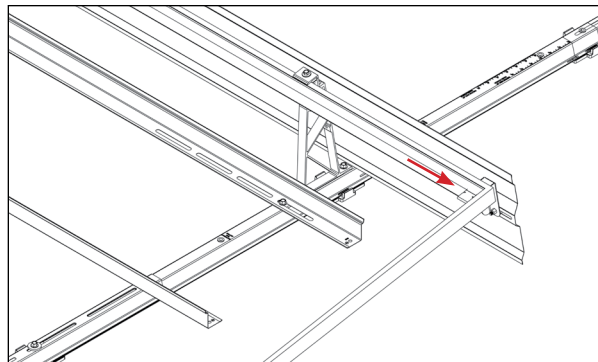

Slide the bracket to align the bracket hole with the wind deflector slot.

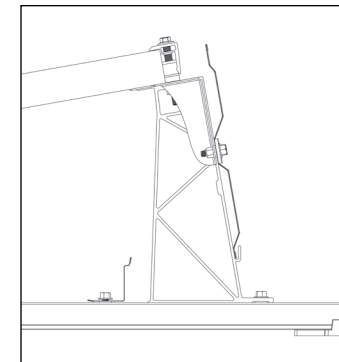

Secure the bracket to the wind deflector with a $\frac{1}{4}$ -20 hex head bolt and washer.

Torque the bolt to 12 ft-lbs.

NOTE: Wind deflector brackets are installed only at the east and west edges of the array.

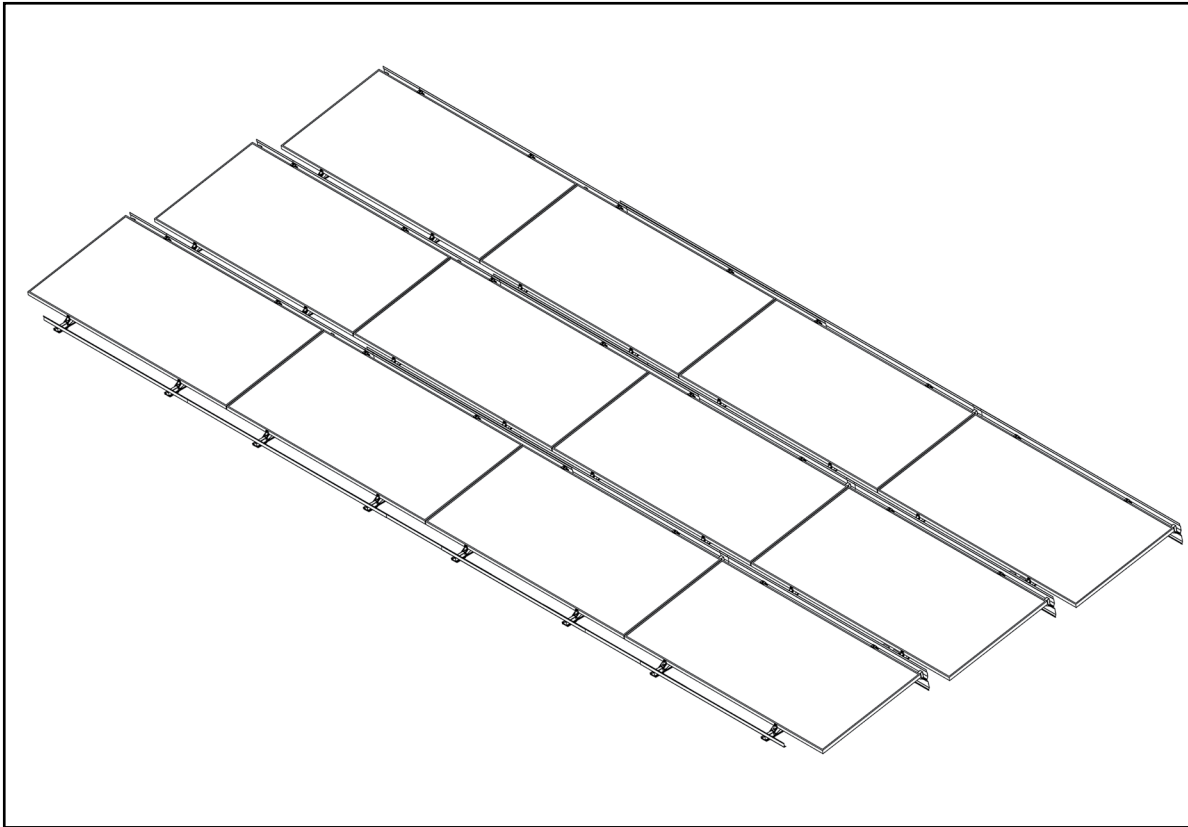

STEP 19:

Check all the fasteners to verify correct torque values.

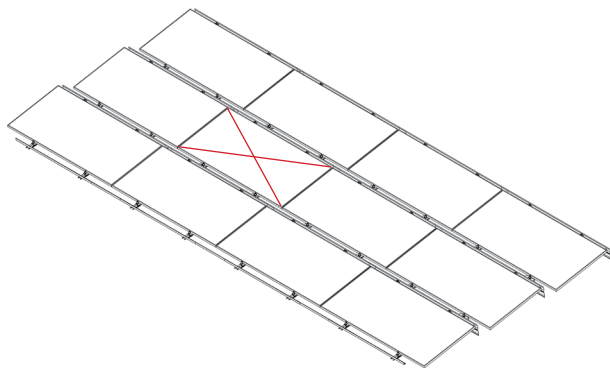

STEP 1: Locate the module to be replaced. Loosen the hexagonal bolt in both the north stanchion's clamp to which the module is connected.

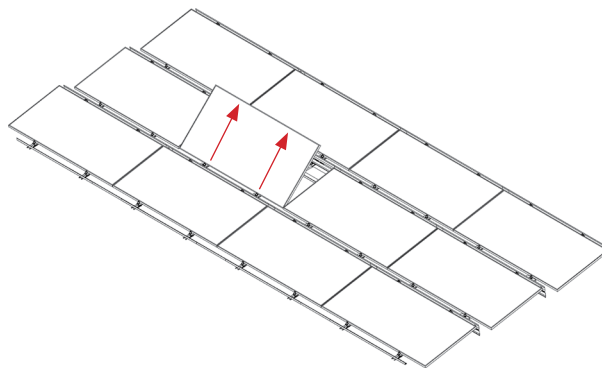

STEP 2: Now lift the module from north edge and rotate it 75° towards south. Loosen the bolt in the south clamp and rotate the slider 90° clockwise.

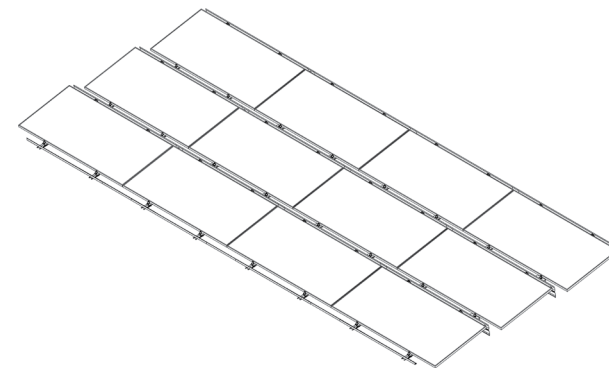

STEP 3: Remove the module and re install the new module by following steps mentioned on *page 15*.

IMPORTANT:

Unirac recommends periodic re-inspection of the installation for loose components, loose fasteners, and any corrosion, such that if found, the affected components are to be immediately re-tightened or replaced.

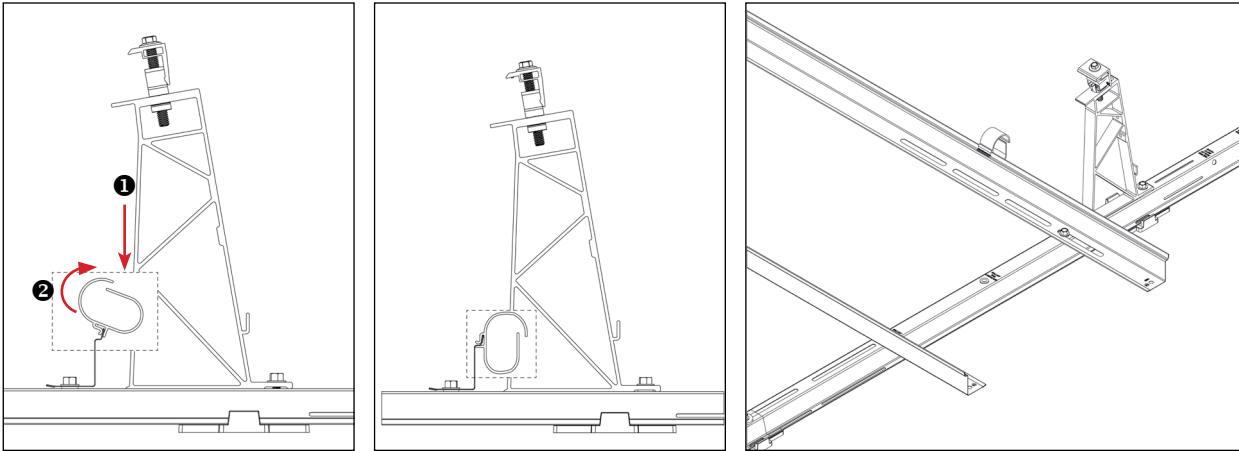

INSTALL WIRE MANAGEMENT CLIP

1. Place the wire management clip on the ballast rail and press it to engage.
2. Rotate the wire management clip to secure it to the ballast rail.

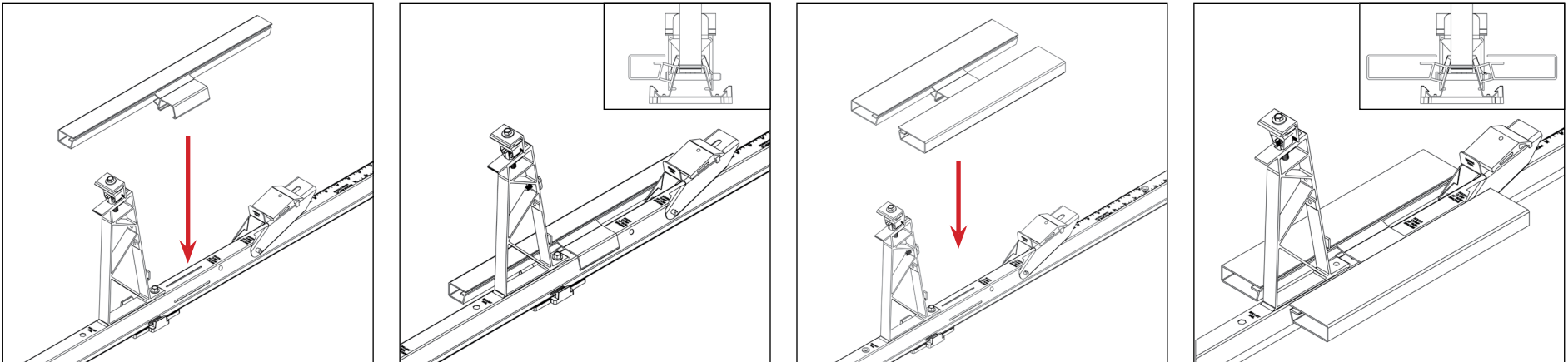

INSTALL INTER-ROW WIRE MANAGEMENT COVER

- Place the Inter-Row wire management cover over the mid-rail and press down until the tabs engage with the side slots of the mid-rail.

INSTALL HOMERUN WIRE MANAGEMENT COVER

- Place the Homerun cover over the mid-rail and press down until the tabs engage with the side slots of the mid-rail.

GROUNDING LUG MOUNTING DETAILS AS REQUIRED BY CODE & ENGINEER OF RECORD: The IlSCO lug has a green colored set screw for grounding indication purposes. One lug is recommended per continuous array, not to exceed 150ft X 150ft.

Unirac GridFlex 10 is intended to be used with PV modules that have a system voltage less than or equal to that allowable by the National Electric Code (NEC). It is the installer's responsibility to check adherence to local codes.

NOTE: The installation must be conducted in accordance with the National Electric Code ANSI / NFPA 70.

GROUND LUG	BOLT SIZE	TORQUE VALUE
IlSCO Lug SGB-4	1/4" - 20	6.5ft-lbs (75 in-lbs)
IlSCO Lug GBL-4	#10 - 32	2.9ft-lbs (35 in-lbs)
Wiley 6.7	1/4" - 20	10ft-lbs (120 in-lbs)

NOTE: In order to prevent corrosion induced by dissimilar metals, it is important to verify that the bare copper wire does not come into contact with aluminum or galvanized steel. These metals must be kept separate.

Although conformance with UL2703 was demonstrated without the use of oxide inhibitor material, it is recommended by IlSCO.

IlSCO SGB-4 Solar Grounding & Bonding



TERMINAL TORQUE:

Install conductor and torque to the following: **4-14 AWG: 35 in-lbs**

IlSCO GBL-4 Solar Grounding & Bonding



TERMINAL TORQUE:

Install conductor and torque to the following: **4-6 AWG: 35 in-lbs, 8 AWG: 25 in-lbs**

Wiley WEWB-Lug 6.7 Solar Grounding & Bonding

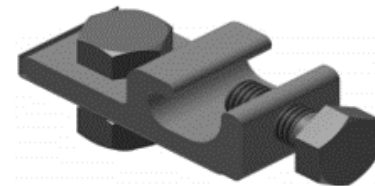

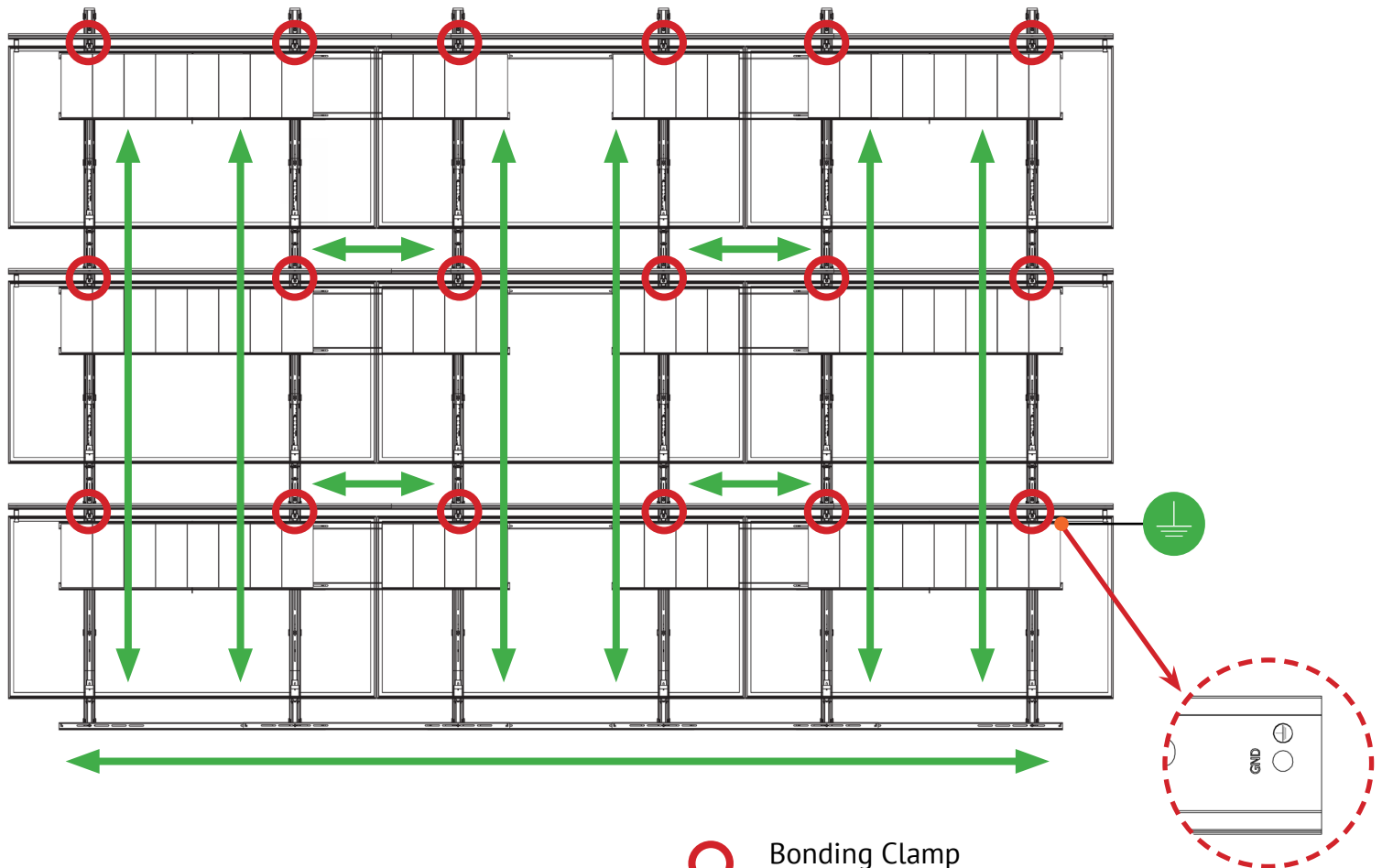

TERMINAL TORQUE:

Install conductor and torque to the following: **4-6 AWG: 10 ft-lbs, 6-14 AWG: 7 ft-lbs**



NOTE: Grounding path can be established by installing the ground lug and copper wire connection at specified locations on ballast rails

-  Bonding Clamp
-  Grounding Lug
-  Min. 10AWG, 105°C Copper Wire

Grounding location on Ballast Rail

SYSTEM LEVEL FIRE CLASSIFICATION: The system fire class rating is only valid when the installation is conducted in accordance with the assembly instructions contained in this manual over a fire resistant roof covering rated for the application. GridFlex 10 has been classified to the system level fire portion of UL2703. It has achieved Class A performance for low sloped roofs when used in conjunction with type 1, 2, 3 with a metal frame, 19, 22, 25, 29 and 30 module constructions. Please see the specific conditions for mounting details described within this document required to maintain the Class A fire rating. Minimum and maximum roof slopes are restricted through the system design and layout rules. The fire classification rating is only valid on roof pitches less than 2:12 (slopes < 2 inches per foot, or 9.5 degrees).

IMPORTANT: Wind Deflectors are required on north edges of arrays to maintain Class A fire rating.

NOTE: Fire Type information can be found on back of modules or through manufacturers documentation. Some building codes and fire codes require minimum clearances around PV racking installations, and the installer should check local building code requirements for compliance.

CLASS A FIRE RATING MOUNTING ORIENTATION

GridFlex 10 has achieved Class A system level fire performance for type 1, 2, 3 with a metal frame, 19, 22, 25, 29 and 30 module constructions. In order to maintain the fire rating, the module J-Box must be oriented away from the array east-west edges.

UL2703 System Label: To comply with UL2703 system rating, North rail has a stamp of system label as shown below

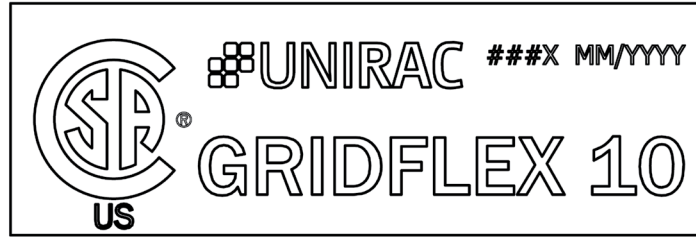

###X - Vendor ID
MM/YYYY - Month and Year of Manufacturing

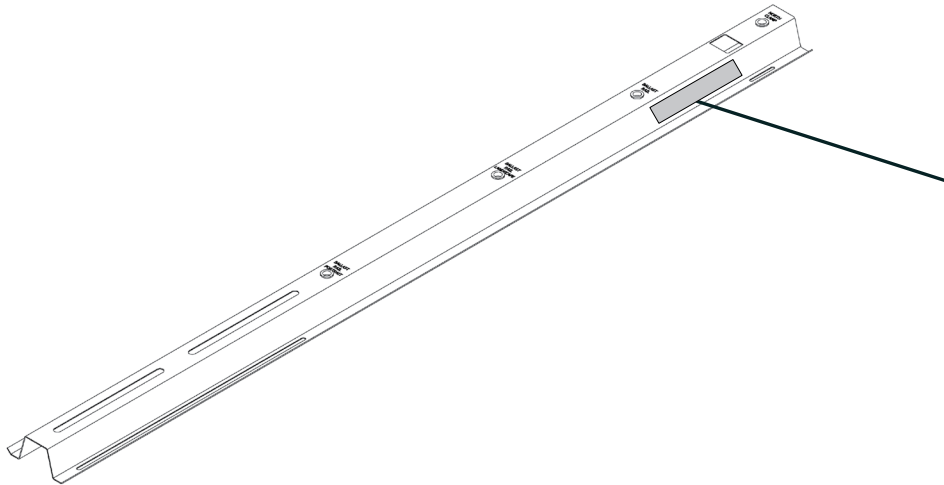

Note: North Rail has a system label at the location shown in the diagram.

MECHANICAL LOAD TEST QUALIFICATION

The GridFlex 10 system has been tested to the mechanical load provisions of UL2703 and covers the following basic parameters:

- PV module may have reduced load rating, independent of the GridFlex 10 rating. Please consult the PV module manufacturer's installation guide for more information.
- Load rating may vary based on PV module area. Please Contact Unirac for more information

See the table below for system design loads in the up, down, and downslope directions for the various system installation configurations

Module Manufacturer	Model	Module Area (sq ft)	Downward Design Load (psf)	Upward Design Load (psf) Non-South Row Modules & South Row Modules with Either Ballasting or Mechanical Attachment South of the South Row Modules	Upward Design Load (psf) South Row Modules with South Rail Stiffener	Downslope Design Load (psf)
Jinko	JKMxxxM-72HL4-TV	27.76	50.48	31.01	#N/A	8.93
ZN Shine	ZXM8-TPLDD132	33.44	17.59	18.55	5.38	6.20
SunPower	SPR-P19-390-COM	22.2	60.12	38.57	#N/A	11.91

NOTE: Design loads are equal to tested loads with 1.5 safety factor applied.

Electrical Bonding and Grounding Test Modules

The list below is not exhaustive of compliant modules but shows those that have been evaluated and found to be electrically compatible with the GridFlex 10 system.

Manufacture	Module Model / Series
Aionrise	AION60G1 AION72G1
Aleo	P-Series S-Series
Aptos Solar	DNA-108-(MF/BF)10-xxxW DNA-120-(MF/BF)10-xxxW DNA-120-(MF/BF)23 DNA-120-(MF/BF)26 DNA-120-MF10 DNA-144-(MF/BF)23 DNA-144-(MF/BF)26 DNA-144-BF10-xxxW-DG
Astronergy	CHSM6612 M, M/HV CHSM6612P Series CHSM6612P/HV Series CHSM72M-HC CHSM72M(DG)/F-BH
Auxin	AXN6M610T AXN6P610T AXN6M612T AXN6P612T AXNG1M SERIES
Axitec	AC-xxx(M/P)/60S AC-xxx(M/P)/72S AC-xxxMH/120(S/V/SB/VB) AC-xxxMH/144(S/V/SB/VB) AC-xxxP/156-60S AC-xxxTGB/144TS
Bluesun Solar	BSMxxxM10-72HBD

Manufacture	Module Model / Series
Boviet Solar	BVM6610 BVM6612 BVM6612M-XXXS-H-HC-BF-DG BVM7612M-H-HC-BF-DG
BYD	MHK-36 Series P6K
Canadian Solar	CS1(H/K/U/Y)-MS CS3K-(MB/MB-AG/MS/P/P HE/PB-AG) CS3L-(MS/P), CS3N-MS CS3U-(MB/MB-AG/MS/P/P HE/PB/PB-AG) CS3W-(MB-AG/MS/P/P-PB-AG) CS3Y-MB-AG, CS3A-M CS6.1-54TM-H CS6.1-60TM-H CS6.1-72TB-H CS6.2-66TB-xxxH CS6K-(M/MS/MS AllBlack/P/P HE) CS6P-(M/P), CS6R-MS CS6R-xxxMS-HL CS6U-(M/P/P HE), CS6W-(MB-AG/MS) CS6W-xxx-TB-AG CS6X-P, CSX-P, CS7L-MB-AG CS7L-MB-AG CS7L-TB-AG CS7L-xxxMB-AG CS7N-xxxMB-AG CS7N-xxx MS CS7N-xxxTB-AG ELPS CS6(A/P)-MM
Centrosolar America	C-Series & E-Series

Manufacture	Module Model / Series
CertainTeed	CT2xxMxx-01 CT2xxPxx-01 CTM10400HC11-06 CTM10400HC11-08 CTM10400HC11-09 CTTCxxxHC12-08 CTxxxHC11-04 CTxxxHC11-06 CTxxxMxx-01 CTxxxMxx-02 CTxxxMxx-03 CTxxxMxx-04 CTxxxPxx-01
Eco Solargy	Apollo 1000 Orion 1000
EMMVEE	ExxxHCBT144-T Titanium Clear
ET Solar	ET AC Module ET-M772BH520-550WW/WB ET-M772BHxxxTW/TB ET Module
First Solar	FS-6XXX(A) FS-6XXX(A)-P FS-6XXX(A)-P-I
Flextronics	FXS-xxxBB
Freedom Forever	FF-MP1-BBB-xxx FF-MP-BBB-xxx
FreeVolt	PVGraf
GCL	GCL-M6 Series GCL-P6

- Unless otherwise noted, all modules listed above include all wattages and specific models within that series. Variable wattages are represented as "xxx"
- Items in parenthesis are those that may or may not be present in a compatible module's model ID
- Slashes "/" between one or more items indicates that either of those items may be the one that is present in a module's model ID.
- The frame profile must not have any feature that might interfere with the bonding devices that are integrated into the racking system
- Use with a maximum over current protection device OCPD of 30A
- Please see GridFlex 10 information at Unirac.com to ensure the exact solar module selected is approved for use with GridFlex 10
- Listed models can be used to achieve a Class A fire system rating, for low slope applications, only when modules fire typed 1, 2, 3 with a metal frame, 19, 22, 25, 29 or 30.

Electrical Bonding and Grounding Test Modules

The list below is not exhaustive of compliant modules but shows those that have been evaluated and found to be electrically compatible with the GridFlex 10 system.

Manufacture	Module Model / Series
Hansol	TD-AN3 TD-AN4 UB-AN1 UD-AN1
Hanwha SolarOne	HSL 60
Heliene	36M, 36P 60M, 60P, 72M & 72P Series 132HC M10 SL Monofacial Module 144HC M10 SL Bifacial 144HC M6 156HC M10 SL Bifacial
H-SAAE	HT60-156M(V)-C HT60-156M-C HT72-156(M/P) HT72-156M(PD)-BF HT72-156M(PDV)-BF HT72-156P(V)-C HT72-156P-C HT72-166M HT72-18X
Hyperion Solar (Runergy)	HY-DH108N8B HY-DH108P8(B) HY-DH144P8 HY-DH156N8 HY-DH156P8
Hyundai	KG, MG, RW, TG, RI, RG, TI, KI, HI Series HiA-SxxxHG HiD-SxxxRG(BK) HiN-SxxxXG(BK) HiN-TxxxNF(BK) HiN-TxxxNI

Manufacture	Module Model / Series
Hyundai(Cont.)	HiN-TxxxNJ HiN-TxxxOJ HiS-S400PI HiS-SxxxGI HiS-SxxxOJ HiS-SxxxXG(BK) HiS-SxxxYH(BK) HiS-TxxxNJ
Illuminate USA	IL5-72HBD-xxx M IL8-66HGD-xxx M
Imperial Star	ISM7-SHDD108-400/M
ITEK	iT-SE Series
Japan Solar	JPS-60 JPS-72 Series
JA Solar	JAM54S30 xxx/MR JAM54S31 xxx/MR JAM6(K)-60/xxx JAM66D45 LB JAM72D10 xxx/MB JAM72D30MB JAM72D40 xxx/MB JAM72S30 /MR JAM78D10MB JAP6(k)-72-xxx/4BB JAP6 60-xxx

Manufacture	Module Model / Series
JA Solar (Cont.)	JAP72S##-xxx/** JAP6(k)-60-xxx/4BB, JAP60S##-xxx/** JAM6(k)-72-xxx/**, JAM72S##-xxx/** JAM6(k)-60-xxx/**, JAM60S##-xxx/** i. #: 01, 02, 03, 09, 10 ii. **: SC, PR, BP, HiT, IB, MW, MR ** = Backsheet, ## Cell technology
Jinko	JKM JKMS Series JKMxxxM-6RL3-B JKMxxxM-72HBL-V JKMxxxM-72HL4-(T)V JKMxxxM-72HL4-TV JKMxxxM-72HLM-TV JKMxxxM-72HL-V JKMxxxM-7RL3-TV JKMxxxM-7RL3-V JKMxxxN-54HL4-B JKMxxxN-72HL4-BDV JKMxxxN-72HL4-BDX JKMxxxN-72HL4-TV
Kyocera	KD-F KU Series
LA Solar	BLA Model LSxxxBF LSxxxBL LSxxxHC LSxxxHC(166) LSxxxHC (430-450 watt range)

- Unless otherwise noted, all modules listed above include all wattages and specific models within that series. Variable wattages are represented as "xxx"
- Items in parenthesis are those that may or may not be present in a compatible module's model ID
- Slashes "/" between one or more items indicates that either of those items may be the one that is present in a module's model ID.
- The frame profile must not have any feature that might interfere with the bonding devices that are integrated into the racking system
- Use with a maximum over current protection device OCPD of 30A
- Please see GridFlex 10 information at Unirac.com to ensure the exact solar module selected is approved for use with GridFlex 10
- Listed models can be used to achieve a Class A fire system rating, for low slope applications, only when modules fire typed 1, 2, 3 with a metal frame, 19, 22, 25, 29 or 30.

Electrical Bonding and Grounding Test Modules

The list below is not exhaustive of compliant modules but shows those that have been evaluated and found to be electrically compatible with the GridFlex 10 system.

Manufacture	Module Model / Series
LG Electronics	LGxxx(A1C/M1C/M1K/N1C/N1K/Q1C/Q1K/ QAC/QAK)-A6 LGxxx(E1C/E1K/N1C/N1K/N2T/N2W/S1C/S2W/Q1C/Q1K)-A5 LGxxx(M1C/N1C/Q1C/Q1K)-N5 LGxxx(N1C/N1K/N2T/N2W)-E6 LGxxx(N1C/N1K/N2W/Q1C/Q1K)-V5 LGxxx(N1C/N1K/N2W/S1C/S2W)-G4 LGxxx(N1K/N1W/N2T/N2W)-L5 LGxxxN1K-B6 LGxxxN2T-B5 LGxxxN2T-J5 LGxxxN2W-B3 LGxxxN3K-V6
LONGi	LR4-60(HPB/HPH) LR4-72(HPH) LR4-72HBD xxxM LR5-54HABB-xxx M (fire type 29 only) LR5-54-HPB-xxx M LR5-72HBD xxx M LR6-60 LR6-60(BK/HPB/HPH/HV/PB/PE/PH) LR6-72 LR6-72(BK/HV/PB/PE/PH) LR7-72HGD-xxx M LR8-54HGBB LR8-66HGD-xxx M RealBlack LR4-60HPB RealBlack LR6-60HPB

Manufacture	Module Model / Series
Maxeon	SPR-MAX3-xxx-COM SPR-MAX3-XXX-R SPR-MAX3-XXX-BLK-R SPR-MAX6-xxx SPR-MAX6-xxx-BLK
Meyer Burger	Meyer Burger Black Meyer Burger White Meyer Burger Glass
Mission Solar Energy	MSE Mono MSE Perc MSExxx(SR8T/SR8K/SR9S/SX5T) MSExxx(SX5K/SX6W) MSExxxHT0B MSExxxSX6Z MSExxxSX9R MSH10-xxxHN4G MSH10-xxxHT4T MSI10-xxxHN4G MSI10-xxxHT4G MSI10-xxxHT4T MSN10xxxHT4T
Mitrex	Mxxx-I3H Mxxx-L3H
Mitsubishi	MJE MLE Series
mSolar	108BB HC Series (TXI10-xxx108BB) 144BB HC Series (TXS6-xxx144BB)
Neo Solar Power Co.	D6M Series

Manufacture	Module Model / Series
NE Solar	NESE xxx-60MH-M6 NESE xxx 66MHB-G12 NESE xxx-72MHB-M10 NESE xxx 72MHT-M10 NESE xxx 72THB-M10 NESE xxx 72MHB-M10
Panasonic	EVPVxxx EVPVxxx(H/K/PK/HK/HK2) VBHNxxxKA VBHNxxxKA03/04 VBHNxxxSA06/SA06B/SA11/SA11B VBHNxxxSA15/SA15B/SA16/SA16B VBHNxxxSA17/SA17G/SA17E/SA18/SA18E VBHNxxxZA01/ZA02/ZA03/VBHNxxx-ZA04
Peimar	SGxxxM (FB/BF) SMxxxM
Philadelphia Solar	PS-M108(HCBF)-400W (30 & 35mm frames) PS-M144(HCBF)-xxxW PS-MNB144(HCBF)-xxxW PS-MNB156(HCBF)-xxxW

- Unless otherwise noted, all modules listed above include all wattages and specific models within that series. Variable wattages are represented as "xxx"
- Items in parenthesis are those that may or may not be present in a compatible module's model ID
- Slashes "/" between one or more items indicates that either of those items may be the one that is present in a module's model ID.
- The frame profile must not have any feature that might interfere with the bonding devices that are integrated into the racking system
- Use with a maximum over current protection device OCPD of 30A
- Please see GridFlex 10 information at Unirac.com to ensure the exact solar module selected is approved for use with GridFlex 10
- Listed models can be used to achieve a Class A fire system rating, for low slope applications, only when modules fire typed 1, 2, 3 with a metal frame, 19, 22, 25, 29 or 30.

Electrical Bonding and Grounding Test Modules

The list below is not exhaustive of compliant modules but shows those that have been evaluated and found to be electrically compatible with the GridFlex 10 system.

Manufacture	Module Model / Series
Phono Solar	PSxxxM1-20/U PSxxxM1-20UH PSxxxM1-20/UH PSxxxM1H-20/U PSxxxM1H-20UH PSxxxM1H-20/UH PSxxxM-24/T PSxxxM-24/TH PSxxxM4(H)-24/TH PSxxxMH-24/T PSxxxMH-24/TH
Prism Solar	P72 Series, P72X-xxx
Q Cells	Peak G5(SC) , G6(+)(SC)(AC), G7, G8(+), Peak L-G5, L-G6, L-G7, L-G8(BFF) Plus, Pro, Peak, G3, G4, Plus, Pro, Peak L-G2, L-G4, L-G5 Q.PEAK DUO(BLK)-G6+ Q.PEAK DUO (BLK)-G7 Q.PEAK DUO (BLK) G8(+) Q.PEAK DUO (BLK) ML-G10(a)(+) Q.PEAK DUO (BLK) ML-G9(+) Q.PEAK DUO BLK G10(+) Q.PEAK DUO BLK G10+ /AC Q.PEAK DUO BLK ML-G10.C+ Q.PEAK DUO BLK ML-G10+ / t Q.PEAK DUO BLK ML-G10+ / TS Q.PEAK DUO-G10+ Q.PEAK DUO G10.C1+ AC Q.PEAK DUO L-(G7/G7.1/G7.2/G7.3/G7.7) Q.PEAK DUO L-(G8/G8.1/G8.2/G8.3) Q.PEAK DUO L-G6.3 / BFG Q.PEAK DUO L-G8.3 (BFF/BFG/BGT)

Manufacture	Module Model / Series
Q Cells (Cont.)	Q.PEAK DUO ML-G12S.3 / BFG, Q.PEAK DUO ML-G12S.d / BFG Q.PEAK DUO XL-(G10/G10.2/G10.3/ G10.c/G10.d) Q.PEAK DUO XL-(G11.2/G11.3) Q.PEAK DUO XL-(G9/G9.2/G9.3) Q.PEAK DUO XL-G10.3/BFG Q.PEAK DUO XL-G10.d/BFG Q.PEAK DUO XL-G11.3/BFG Q.PEAK DUO XL-G11S Q.PEAK DUO XL-G11S.3 / BFG Q.PEAK DUO XL-G9.3/BFG Q.TRON BLK M-G2+ AC Q.TRON BLK M-G2.H+ Q.TRON BLK M-G2.H1+/AC. Q.TRON BLK M-G2+ SERIES Q.TRON M-G2+ SERIES Q.TRON XL-G2.3/BFG Q.PEAK DUO BLK ML-G10.XY+/AC (where "X" = any letter between A to W, where "Y" = any number between 1 to 9.)
REC	RECxxxAA (BLK/Pure/Pure-R/ Pure-RX/ Pure 2/ Pro M) RECxxxNP (N-PEAK) RECxxxNP2 (Black) RECxxxNP3 Black RECxxxPE RECxxxPE72 RECxxxTP RECxxxTP2(M/BLK2)

Manufacture	Module Model / Series
REC(Cont.)	RECxxxTP2S(M)72 RECxxxTP3M (Black) RECxxxTP4 (Black) RECxxxTP72
Renesola	All 60-cell modules RS6-xxxNBG-E3
Risen	RSM Series, RSM110-8-xxxBMDG
SEG Solar	SEG-xxx-BMA-BG SEG-xxx-BMA-HV SEG-xxx-BMA-TB SEG-xxx-BMB-BG SEG-xxx-BTA-BG SEG-xxx-BMB-HV SEG-XXX-BMB-TB SEG-xxx-BMD-BG SEG-xxx-BMD-HV SEG-xxx-BMD-TB SEG-xxx-BTB-BG SEG-xxx-BTD-BG
S-Energy	SL45-60BG1/BHI SL45-60MBI-xxxZ SN60 Series SN72
Seraphim	SEG-(6PA/6PB/6MA/6MA-HV/6MB/E01/ E11) SRP-(6QA/6QB) SRP-xxx-6MB-HV SRP-320-375-BMB-HV SRP-xxx-BMC-HV SRP-390-450-BMA-HV SRP-xxx-BMZ-HV SRP-390-405-BMD-HV

- Unless otherwise noted, all modules listed above include all wattages and specific models within that series. Variable wattages are represented as "xxx"
- Items in parenthesis are those that may or may not be present in a compatible module's model ID
- Slashes "/" between one or more items indicates that either of those items may be the one that is present in a module's model ID.
- The frame profile must not have any feature that might interfere with the bonding devices that are integrated into the racking system
- Use with a maximum over current protection device OCPD of 30A
- Please see GridFlex 10 information at Unirac.com to ensure the exact solar module selected is approved for use with GridFlex 10
- Listed models can be used to achieve a Class A fire system rating, for low slope applications, only when modules fire typed 1, 2, 3 with a metal frame, 19, 22, 25, 29 or 30.

Electrical Bonding and Grounding Test Modules

The list below is not exhaustive of compliant modules but shows those that have been evaluated and found to be electrically compatible with the GridFlex 10 system.

Manufacture	Module Model / Series
Seraphim(Cont.)	SRP-xxx-BTA-BG SRP-xxx-BTB-BG SRP-xxx-BTC-BG
Sharp	NU-SA NU-SC Series
Silfab	SILxxx(BG/BK/BL/HC/HC+/HL/HM/HN/ ML/NL/NT/NX/NU/QD/QM) SIL-xxx XL SIL-xxx XM SIL-xxx XM+ SLA-M, SLA-P, SLG-M, SLG-P & BC Series
Sirius	ELNSM54M-HC-BF Series ELNSM54M-HC Series
Solar4America	S4Axxx-108MH10BB S4Axxx-108MH10xxx S4Axxx-108TH10xxx S4Axxx-144MH10xxx S4Axxx-144TH10xxx S4Axxx-144TH16xxx S4Axxx-72MH5BB
SolarEver USA	SE-166*83-xxxM-120N SE-182*91-xxxM-108N SE-182*105-xxxM-96-BD
Solaria	PowerXT-xxxR-(AC/PD/BD) PowerXT-xxxC-PD PowerXT-xxxR-PM (AC) PowerX-400R
Solartech	STU HJT, STU PERC & Quantum PERC
SolarWorld	Sunmodule Protect Sunmodule Plus/Pro

Manufacture	Module Model / Series
Sonali	SS-M-360 to 390 Series SS-M-390 to 400 Series SS-M-440 to 460 Series SS-M-430 to 460 BiFacial Series
Sun Edison	F-Series R-Series
Suniva	MV Series Optimus Series (35mm)
Sunmac Solar	M754SH-BB Series
SunPower	AC, X-Series, E-Series & P-Series SPR E20 435 COM (G4 Frame) Axxx-BLK-G-AC SPR-Mxxx-H-AC SPR-Mxxx-BLK-H-AC
SunPro	SPDGxxx-120M12
SunTech	STP STPXXXS - B60/Wnhb
Talesun	Hipor M Smart TD6I72M TD7G72M TM3G54M TM3G66M TM7G54M TM7G60M TM7G72M TP572 TP596 TP654 TP660

Manufacture	Module Model / Series
Talesun(Cont.)	TP672 TP6F72M TP6F72M(H) TP7G54M(H)
Tesla	SC, SC B, SC B1, SC B2, TxxxS, TxxxH
Thornova	TS-BG54 TS-BG72 TS-BGT72(xxx)
Trina	DE06 DE09.05 DE09C.07 DEG15HC.20(II) DEG15MC.20(II) DEG15VC.20(II) DE18M(II) DEG18MC.20(II) DE19 DEG19C.20 PA05 PD05 DD05, DD06 PD14, PE14, DD14, DE14, DE15, DE15V(II) TSM-DE06X.05(II) TSM-DE09.05 TSM-DE09.08 TSM-DE09C.07 TSM-DEG21C.20 TSM-NE09RC.05 TSM-NE09RH.05 TSM-NE19RC TSM-NEG19RC.20 TSM-NEG21C.20

- Unless otherwise noted, all modules listed above include all wattages and specific models within that series. Variable wattages are represented as "xxx"
- Items in parenthesis are those that may or may not be present in a compatible module's model ID
- Slashes "/" between one or more items indicates that either of those items may be the one that is present in a module's model ID.
- The frame profile must not have any feature that might interfere with the bonding devices that are integrated into the racking system
- Use with a maximum over current protection device OCPD of 30A
- Please see GridFlex 10 information at Unirac.com to ensure the exact solar module selected is approved for use with GridFlex 10
- Listed models can be used to achieve a Class A fire system rating, for low slope applications, only when modules fire typed 1, 2, 3 with a metal frame, 19, 22, 25, 29 or 30.

Electrical Bonding and Grounding Test Modules

The list below is not exhaustive of compliant modules but shows those that have been evaluated and found to be electrically compatible with the GridFlex 10 system.

Manufacture	Module Model / Series
TSMC	TS-150C2 CIGSw
Universal Solar	UNI4xx-144BMH-DG UNI5xx-144BMH-DG UNIxxx-108M-BB UNIxxx-120M-BB UNIxxx-120MH
Upsolar	UP-MxxxM(-B) UP-MxxxP
URECO	D7Kxxx(H7A/H8A) D7Mxxx(H7A/H8A) F6MxxxE7G-BB FAKxxx(C8G/E8G) FAMxxxE7G-BB FAMxxxE8G(-BB) FBKxxxM8G FBMxxxM7G-BB FBMxxxMFG-BB
Vikram Solar	Eldora, Somera, Ultima PREXOS VSMDHT.60.AAA.05 PREXOS VSMDHT.72.AAA.05 Paradea VSMDH.72.AAA.05
Vina	VNS-72M1-5-xxxW-1.5 VNS-72M3-5-xxxW-1.5 VNS-144M1-5-xxxW-1.5 VNS-144M3-5-xxxW-1.5 VNS-120M3-5-xxxW-1.0

Manufacture	Module Model / Series
VSUN	VSUN4xx-144BMH VSUN4xx-144BMH-DG VSUN5xx-144BMH-DG VSUNxxx-108BMH VSUNxxx-108M-BB VSUNxxx-120BMH VSUNxxx-120M-BB VSUNxxx-132BMH VSUNxxx-144BMH VSUNxxx-144M-BB VSUNxxx-144MH VSUNxxx-144M-BW VSUNxxx-60M-BB VSUNxxx-72MH VSUNxxxN-144BMH VSUNxxxN-144MH
Waaree	Arka Series WSMDi
Winaico	WSP Series WST
Yingli	YGE & YLM Series
Yotta Energy	YSM-B450-1
ZNShine Solar	ZXM6-72 Series ZXM6-NH120 Series ZXM6-NH144 ZXM6-NHLDD144 ZXM7-SH108 Series ZXM7-SHDB144 ZXM7-SHLDD144 ZXM7-UHLDD144 ZXM8-GPLDD132 Series ZXM8-TPLDD132

- Unless otherwise noted, all modules listed above include all wattages and specific models within that series. Variable wattages are represented as "xxx"
- Items in parenthesis are those that may or may not be present in a compatible module's model ID
- Slashes "/" between one or more items indicates that either of those items may be the one that is present in a module's model ID.
- The frame profile must not have any feature that might interfere with the bonding devices that are integrated into the racking system
- Use with a maximum over current protection device OCPD of 30A
- Please see GridFlex 10 information at Unirac.com to ensure the exact solar module selected is approved for use with GridFlex 10
- Listed models can be used to achieve a Class A fire system rating, for low slope applications, only when modules fire typed 1, 2, 3 with a metal frame, 19, 22, 25, 29 or 30.