



Descriptive Report

MASTER CONTRACT: 0000266909
REPORT: 70131735
PROJECT: 80286080

EDITION

Edition	Issued On	Project	Location	Prepared By	Authorized By
Edition 1	September 20, 2017	70131735	Irvine	Michael Hoffnagle	Michael Hoffnagle
Edition 39	June 17, 2025	80238341	USA Irvine	Michael Hoffnagle	Michael Hoffnagle
Edition 40	August 28, 2025	80262199	USA Irvine	Michael Hoffnagle	Michael Hoffnagle
Edition 41	October 02, 2025	80270725	USA Irvine	Michael Hoffnagle	Michael Hoffnagle
Edition 42	December 12, 2025	80274641	USA Irvine	Michael Hoffnagle	Michael Hoffnagle
Edition 43	February 10, 2026	80276813	USA Irvine	Michael Hoffnagle	Michael Hoffnagle
Edition 44	March 24, 2026	80286080	USA Irvine	Michael Hoffnagle	Michael Hoffnagle

CONTENTS

Certificate of Compliance + Supplement - Page 1 to 24
Description and Tests - Page 1 to 107
Att1 Installation Manual SM– Pages 1 to 57
Att2 Schematics SM/Unirac Large Array– Pages 1 to 153
Att3 Installation Manual Unirac Large Array – Pages 1 to 35
Att4 RM5_ Installation Manual - 1 to 27
Att5 RMDT_ Installation Manual - 1 to 26
Att6 RM series schematics – 1 to 40
Att7 GFT Installation Manual – Pages 1 to 47
Att8 GFT HD Rail Installation - Pages 1
Att9 GFT Schematics – Pages 1 to 71
Att10 NXT UMOUNT Installation Manual – Pages 1 to 51
Att11 Schematics NXT UMOUNT – Pages 1 to 220
Att12 SM Ascender 2P Elevated Installation Manual – Pages 1 to 40
Att13 SM Ascender 2P NON Elevated Installation Manual – Pages 1 to 39
Att14 SM Ascender 1P Non Elevated Installation Manual – Pages 1 to 36
Att15 SM Ascender 1P Elevated Installation Manual – Pages 1 to 39
Att16 Schematics SM Ascender – Pages 1 to 48
Att17 SM Ascender Flush Mount Installation Manual – Pages 1 to 31
Att18 S-5 schematics and installation – Pages 1 to 19
Att19 SM_NXT_Tilt Leg Install Addendum_ – Pages 1 to 18
Att20 SM_NXT_Tilt Leg Install Addendum Trinity_ – Pages 1 to 21
Att21 GridFlex 10D Schematics – Pages 1 to 49
Att22 GridFlex 10D Installation Manual – Pages 1 to 60

This report shall not be reproduced, except in full, without the approval of CSA Group.

34 Bunsen, Irvine, CA 92618
Telephone: 949-733-4300 Fax: 949-733-4320

- Att23 GFT Flushmount Installation Manual – Pages 1 to 36
- Att24 NXT UMOUNT® GHOST RAIL Installation Manual - Pages 1 to 49
- Att25 EcoFoot2+ Installation Manual – Pages 1 to 32
- Att26 EcoFoot5D Installation Manual – Pages 1 to 30
- Att27 EcoFoot Schematics – Pages 1 to 71
- Att28 RM10 EVO Installation Manual – Pages 1 to 28
- Att29 RM10 EVO Schematics – Pages 1 to 26
- Att30 SFM Installation Manual – Pages 1 to 35
- Att31 SFM Schematics – Pages 1 to 82

PRODUCTS

Class 5313 02 POWER SUPPLIES - PHOTOVOLTAICS - PV Racking

Class 5313 82 POWER SUPPLIES - PHOTOVOLTAICS - PV Racking and clamping systems-Certified to US Standards

EcoFoot5D is a 5 degree ballasted PV racking system that is installed parallel to the roof in the landscape orientation.

EcoFoot2+ is a ballasted PV racking system that is installed parallel to the roof in both portrait and landscape orientations.

Model(s)
EcoFoot5D, EcoFoot2+

EcoFoot5D & EcoFoot2+

The systems listed are low slope ballasted systems designed to provide bonding/grounding, and mechanical stability for photovoltaic modules. The system employs polymeric bays and is ballasted with ASTM C1491 concrete blocks. Modules are secured to the racking system with anodization-piercing aluminum clamps. The modules are bonded to the racking system via the clamp’s stainless steel bonding pin. These systems employ steel wind deflectors that carry the bond path along rows of modules as well as perform a fire mitigation function. The system is grounded with 10 AWG copper wire to bonding/grounding lugs.

The grounding of the system is intended to comply with the latest edition of the National Electrical Code, to include NEC 250 & 690. Local codes compliance is required, in addition to national codes. All grounding/bonding connections are to be torqued in accordance with the Installation Manual and the settings used during the certification testing for the current edition of the project report.

Fire ratings of Class A with Type 1, 2, type 3 (with metallic frame), 19, 22, 25, 29, 30, and 38 for low slope applications. Tested at 5" interstitial gap which allows installation at any stand-off height.

Latest EcoFoot5D Install Manual revision: PUB2026JAN23

Latest EcoFoot2+ Install Manual revision: PUB2026JAN23

UL 2703 Mechanical Load ratings for tested module area 29.49 sq ft:

Standard Configuration (No Additional Mid Bays or Supports)	
Downward Design Load (lb/ft ²)	14.27
Upward Design Load (lb/ft ²)	14.13
Down-Slope Load (lb/ft ²)	5.0

Standard Configuration with Additional Mid Support Installed	
Downward Design Load (lb/ft ²)	41.63
Upward Design Load (lb/ft ²)	14.13
Down-Slope Load (lb/ft ²)	5.0

UL 2703 and TIL Mechanical Load ratings tested module area 27.78 sq ft:

Standard Configuration (No Additional Mid Bays or Supports)	
Downward Design Load (lb/ft ²)	17.35
Upward Design Load (lb/ft ²)	17.93
Down-Slope Load (lb/ft ²)	5.27

UL 2703 and TIL Mechanical Load ratings tested module area 29.10 sq ft:

Standard Configuration with Additional Mid Bays Installed	
---	--

Downward Design Load (lb/ft ²)	36.30
Upward Design Load (lb/ft ²)	9.65
Down-Slope Load (lb/ft ²)	5.27

Ground Fixed Tilt is a Roll Formed Steel and extruded aluminum rail PV racking system that is ground mounted in portrait orientation

GFT Flush Mount is a Roll Formed Steel and extruded aluminum rail PV racking system that is roof mounted in portrait orientation

Model(s)
GFT, GFT Flush Mount

Ground Fixed Tilt

The racking system listed is designed to provide bonding/grounding, and mechanical stability for photovoltaic modules. Racking system is secured to the ground with roll-formed steel piles. Modules are secured to the racking system with stainless steel or aluminum mid clamps and Aluminum end clamps. The modules are bonded to the racking system with bonding mid clamps with piercing points. The system is grounded with 10 AWG copper wire to bonding/grounding lugs.

The grounding of the system is intended to comply with the latest edition of the National Electrical Code, to include NEC 250 & 690. Local codes compliance is required, in addition to national codes. All grounding/bonding connections are to be torqued in accordance with the Installation Manual and the settings used during the certification testing for the current edition of the project report.

The mechanical load ratings from the SM test data will be applied to the GFT model.

Fire Testing is not applicable due to being a ground mount system.

Latest Install Manual revisions:

PUB2026JAN23

PUB2024FEB09, GFT_HD_RAIL_20240209

Mechanical ratings:

Module Area up to 22.2 sq ft	
Downward Design Load (lb/ft ²)	113.5
Upward Design Load (lb/ft ²)	50.7
Down-Slope Load (lb/ft ²)	16.13

Module Area up to 27.12 sq ft	
-------------------------------	--

Downward Design Load (lb/ft ²)	33.9
Upward Design Load (lb/ft ²)	33.9
Down-Slope Load (lb/ft ²)	16.5

Module Area up to 29.49 sq ft	
Downward Design Load (lb/ft ²)	31.18
Upward Design Load (lb/ft ²)	31.18
Down-Slope Load (lb/ft ²)	9.8

Module Area up to 33.43 sq ft	
Downward Design Load (lb/ft ²)	27.79
Upward Design Load (lb/ft ²)	28.05
Down-Slope Load (lb/ft ²)	9.8

GFT Flush Mount

The racking system listed is designed to provide bonding/grounding, and mechanical stability for photovoltaic modules. Racking system is secured to the roof with the Flashloc components through the roofing material to building structure. Modules are secured to the racking system with stainless steel or aluminum mid clamps and Aluminum end clamps. The modules are bonded to the racking system with bonding mid clamps with piercing points. The system is grounded with 10 AWG copper wire to bonding/grounding lugs. Fire ratings of Class A with Type 1, 2, 3 (with metallic frame), 4 (with trim), 5 (with trim), 10(with metallic frame), 19, 22, 25, 29, or 30 for steep slope. Class A with Type 1, 2, 29 or 30 for low slope. Tested at 5” interstitial gap which allows installation at any stand-off height.

The grounding of the system is intended to comply with the latest edition of the National Electrical Code, to include NEC 250 & 690. Local codes compliance is required, in addition to national codes. All grounding/bonding connections are to be torqued in accordance with the Installation Manual and the settings used during the certification testing for the current edition of the project report.

The mechanical load ratings from the SM test data will be applied to the GFT model.

Latest Install Manual revisions:

PUB2026JAN23

Mechanical ratings:

Module Area up to 22.2 sq ft	
Downward Design Load (lb/ft ²)	113.5
Upward Design Load (lb/ft ²)	50.7
Down-Slope Load (lb/ft ²)	16.13

Module Area up to 27.12 sq ft	
Downward Design Load (lb/ft ²)	33.9
Upward Design Load (lb/ft ²)	33.9
Down-Slope Load (lb/ft ²)	16.5

Module Area up to 29.49 sq ft	
Downward Design Load (lb/ft ²)	31.18
Upward Design Load (lb/ft ²)	31.18
Down-Slope Load (lb/ft ²)	9.8

Module Area up to 33.43 sq ft	
Downward Design Load (lb/ft ²)	27.79
Upward Design Load (lb/ft ²)	28.05
Down-Slope Load (lb/ft ²)	9.8

GridFlex 10D is a low slope ballasted roof mounted PV racking system

Model(s)
GridFlex 10D

GridFlex 10D

The system listed is designed to provide bonding/grounding, and mechanical stability for photovoltaic modules. The system is a low slope ballasted system. Modules are secured to the racking system with aluminum clamps. The modules are bonded to the racking system via the clamps' stainless steel bonding pins. Fire ratings of Class A with Type 1, 2, 3 (with metallic frame), 10(with metallic frame), 19, 22, 25, 29, or 30 for low slope applications. Tested at 5" interstitial gap which allows installation at any stand-off height.

The grounding of the system is intended to comply with the latest edition of the National Electrical Code, to include NEC 250 & 690. Local codes compliance is required, in addition to national codes. All grounding/bonding connections are to be torqued in accordance with the Installation Manual and the settings used during the certification testing for the current edition of the project report.

Latest GridFlex 10D Install Manual revision: PUB2026FEB04

GridFlex 10D UL 2703 Mechanical Load ratings for tested module area 22.20 sq ft:

GridFlex 10D	
Downward Design Load (lb/ft ²)	60.12
Upward Design Load (lb/ft ²)	38.57 ¹
Down-Slope Load (lb/ft ²)	11.91

GridFlex 10D UL 2703 Mechanical Load ratings for tested module area 27.76 sq ft:

GridFlex 10D	
Downward Design Load (lb/ft ²)	50.48
Upward Design Load (lb/ft ²)	31.01 ¹
Down-Slope Load (lb/ft ²)	10.03

GridFlex 10D UL 2703 Mechanical Load ratings for tested module area 33.44 sq ft:

GridFlex 10D	
Downward Design Load (lb/ft ²)	17.59
Upward Design Load (lb/ft ²)	18.55 ¹
Upward Design Load (lb/ft ²)	5.38 ²
Down-Slope Load (lb/ft ²)	6.20

GridFlex 10D UL 2703 and TIL Mechanical Load ratings tested module area 27.76 sq ft:

GridFlex 10D	
Downward Design Load (lb/ft ²)	40.5
Upward Design Load (lb/ft ²)	34.1
Down-Slope Load (lb/ft ²)	7.2

¹This is the design load value in uplift for non-south row modules and south row modules with either ballasting or mechanical attachments south of the south row modules

²¹This is the design load value in uplift for south row modules that utilize the south rail stiffener component and do not utilize ballasting or mechanical attachments south of the south row modules

Flush to Roof is an extruded aluminum rail PV racking system that is installed parallel to the roof in landscape or portrait orientations

Model(s)
NXT UMOUNT

The system listed is designed to provide bonding/grounding, and mechanical stability for photovoltaic modules. The system is secured to the roof with the L-Foot components through the roofing material to building structure. Modules are secured to the racking system with aluminum mid clamps and aluminum end clamps. The modules are bonded to the racking system with bonding mid and end clamps with piercing points. Fire ratings of Class A with Type 1, 2, 3 (with metallic frame), 10(with metallic frame), 19, 22, 25, 29, 30 or 38 for steep and low slope. Tested at 5" interstitial gap which allows installation at any stand-off height.

The grounding of the system is intended to comply with the latest edition of the National Electrical Code, to include NEC 250 & 690. Local codes compliance is required, in addition to national codes. All grounding/bonding connections are to be torqued in accordance with the Installation Manual and the settings used during the certification testing for the current edition of the project report.

NXT Tilt Legs is a flat roof configuration of the NXT UMount system that utilizes an attachment variation that involves structural standoffs to achieve a range of module tilt angles. The NXT Tilt Legs installation instructions are captured in an Installation Addendum that covers both the SolarMount Tilt Legs system and the NXT Tilt Legs system. NXT Tilt Legs has mechanical load ratings independent of the NXT UMount mechanical load ratings.

NXT UMount Ghost Rail is a version of NXT UMount system where the south row is identical to NXT UMount in that there are two rails in that row of modules. On all non-south rows instead of two rails per row of modules there is 1 rail per row of modules and the absent rail is replaced with a coupler component.

Latest SolarMount NXT Tilt Legs Installation Addendum revisions: PUB2025APR25, PUB2025APR25-Trinity, & PUB2025SEP26_New Logo

Latest NXT UMount Install Manual revision: PUB2026MAR01

Latest NXT UMount Ghost Rail Install Manual Revision: PUB2026JAN23

NXT UMount UL 2703 Mechanical Load ratings for tested module area 21.86 sq ft:

NXT Systems without DTD Butyl Attachment P30817211, Rail Splice P30808218, or Rail Clamp P30817214	
Downward Design Load (lb/ft ²)	113.7
Upward Design Load (lb/ft ²)	51.1
Down-Slope Load (lb/ft ²)	16.8

NXT Systems with DTD Butyl Attachment P30817211, Rail Splice P30808218, or Rail Clamp P30817214	
Downward Design Load (lb/ft ²)	51.1
Upward Design Load (lb/ft ²)	51.1
Down-Slope Load (lb/ft ²)	16.8

NXT UMount UL 2703 and TIL Mechanical Load ratings tested module area 27.76 sq ft:

NXT Systems without DTD Butyl Attachment P30817211, Rail Splice P30808218, or Rail Clamp P30817214	
Downward Design Load (lb/ft ²)	50.1
Upward Design Load (lb/ft ²)	22.2
Down-Slope Load (lb/ft ²)	8.0

UL 2703 and TIL Mechanical Load ratings tested module area 29.49 sq ft:

NXT Systems with all components included in PUB2023NOV10 Install Manual	
Downward Design Load (lb/ft ²)	37.06
Upward Design Load (lb/ft ²)	20.97
Down-Slope Load (lb/ft ²)	7.53

UL 2703 and TIL Mechanical Load ratings tested module area 30.05 sq ft:

NXT Systems with all components included in PUB2023NOV10 Install Manual	
Downward Design Load (lb/ft ²)	36.5
Upward Design Load (lb/ft ²)	20.96
Down-Slope Load (lb/ft ²)	7.6

NXT HD Rail UL 2703 Mechanical Load ratings:

Module Area up to 27.81 sq ft	
Downward Design Load (lb/ft ²)	50.47
Upward Design Load (lb/ft ²)	25.57
Down-Slope Load (lb/ft ²)	8.2

NXT Tilt Legs UL 2703 Mechanical Load ratings:

Module Area up to 21.05 sq ft	
Downward Design Load (lb/ft ²)	51
Upward Design Load (lb/ft ²)	32.23
Down-Slope Load (lb/ft ²)	10.93

Module Area up to 27.81 sq ft	
Downward Design Load (lb/ft ²)	30.35
Upward Design Load (lb/ft ²)	24.1
Down-Slope Load (lb/ft ²)	8.13

NXT Tilt Legs Test Loads:

Module Area up to 21.05 sq ft	
Downward Design Load (lb/ft ²)	76.5
Upward Design Load (lb/ft ²)	48.35
Down-Slope Load (lb/ft ²)	16.40

Module Area up to 27.81 sq ft	
Downward Design Load (lb/ft ²)	45.53
Upward Design Load (lb/ft ²)	36.15
Down-Slope Load (lb/ft ²)	12.2

NXT UMount Ghost Rail UL 2703 Mechanical Load ratings:

Module Area up to 21.65 sq ft	
Downward Design Load (lb/ft ²)	16.8
Upward Design Load (lb/ft ²)	28.2
Down-Slope Load (lb/ft ²)	9.6

NXT UMount Ghost Rail Test Loads:

Module Area up to 21.65 sq ft	
Downward Design Load (lb/ft ²)	25.2
Upward Design Load (lb/ft ²)	42.3
Down-Slope Load (lb/ft ²)	14.5

RM DT, East West facing, low slope, ballasted roof mount PV racking system
 RM 5 South, South facing, low-slope, ballasted roof-mount PV racking system

Model(s)
RM 5 South, RM DT

RM 5 South and RM DT

The systems listed are designed to provide bonding/grounding, and mechanical stability for photovoltaic modules. The system employs galvanized steel bays, ballasted with ASTM C1491 concrete blocks. Modules are secured to the racking system with stainless steel end and mid clamps. Where applicable, the system may employ fire skirts and/or wind deflectors made from 18 gauge G180 steel. The modules are bonded to the racking system with anodization-piercing clamps. The system is grounded with 10 AWG copper wire to bonding/grounding lugs. Fire ratings of Class A with Type 1, 2, 29, or 30 for low slope with fixed interstitial gap per design of racking system. RM5 requires wind deflectors on North edge.

The system may employ bay-mounted or module mounted optimizers/micro-inverters.

Both models are identical in terms of construction material, module clamps, bonding/grounding, and performance rating with the exception of the tilt angle and direction of the systems.

Latest RM5 Install Manual revision: PUB2026JAN23

Latest RMDT Install Manual revision: PUB2026JAN23

Mechanical ratings for both models:

Module Area up to 27.76 sq ft System Configuration without Mid Bays Included	
Downward Design Load (lb/ft ²)	36.2
Upward Design Load (lb/ft ²)	17.24
Down-Slope Load (lb/ft ²)	5

Module Area up to 33.44 sq ft System Configuration with Mid Bays Included	
Downward Design Load (lb/ft ²)	33.3
Upward Design Load (lb/ft ²)	23.52
Down-Slope Load (lb/ft ²)	5.26

Module Area up to 33.44 sq ft System Configuration without Mid Bays Included	
Downward Design Load (lb/ft ²)	14.85
Upward Design Load (lb/ft ²)	15.66
Down-Slope Load (lb/ft ²)	5.13

RM10 EVO is a ballasted PV racking system that is installed parallel to the roof in landscape orientations.

Model(s)
RM10 EVO

RM10 EVO

The system listed is a low slope ballasted system designed to provide bonding/grounding, and mechanical stability for photovoltaic modules. The system employs aluminum bays and is ballasted with ASTM C1491 concrete blocks. Modules are secured to the racking system with anodization-piercing aluminum clamps. The modules are bonded to the racking system via the clamp’s stainless steel bonding washer. The system is grounded with 10 AWG copper wire to bonding/grounding lugs.

The grounding of the system is intended to comply with the latest edition of the National Electrical Code, to include NEC 250 & 690. Local codes compliance is required, in addition to national codes. All grounding/bonding connections are to be torqued in accordance with the Installation Manual and the settings used during the certification testing for the current edition of the project report.

Fire ratings of Class A with Type 1, 2, type 3 (with metallic frame), 19, 22, 25, 29, and 30 for low slope applications. Tested at 5" interstitial gap which allows installation at any stand-off height.

Latest RM10 EVO Install Manual revision: PUB2026JAN23

UL 2703 Mechanical Load ratings for tested module area 33.44 sq ft:

Standard Configuration (No Additional Mid Bays or Supports)	
Downward Design Load (lb/ft ²)	13.57
Upward Design Load (lb/ft ²)	15.88
Down-Slope Load (lb/ft ²)	5.0

Standard Configuration with Additional Mid Support Installed	
Downward Design Load (lb/ft ²)	33.37
Upward Design Load (lb/ft ²)	15.88
Down-Slope Load (lb/ft ²)	5.0

Standard Configuration with Additional Mid Bay Installed	
Downward Design Load (lb/ft ²)	33.37
Upward Design Load (lb/ft ²)	26.63
Down-Slope Load (lb/ft ²)	5.0

UL 2703 and TIL Mechanical Load ratings tested module area 27.78 sq ft:

Standard Configuration (No Additional Mid Bays or Supports)	
Downward Design Load (lb/ft ²)	17.3
Upward Design Load (lb/ft ²)	17.88
Down-Slope Load (lb/ft ²)	5.0

UL 2703 and TIL Mechanical Load ratings tested module area 27.66 sq ft:

Standard Configuration with Additional Mid Bays Installed	
Downward Design Load (lb/ft ²)	28.59
Upward Design Load (lb/ft ²)	26.46
Down-Slope Load (lb/ft ²)	5.0

UL 2703 and TIL Mechanical Load ratings tested module area 29.10 sq ft:

Standard Configuration with Additional Mid Bays Installed	
Downward Design Load (lb/ft ²)	34.47
Upward Design Load (lb/ft ²)	18.39
Down-Slope Load (lb/ft ²)	5.0

SFM Flush to Roof is an extruded aluminum rail PV racking system that is installed parallel to the roof in landscape or portrait orientations.

Model(s)
SFM (Sun Frame Microrail)

SFM (Sun Frame Microrail)

The system listed is designed to provide bonding/grounding, and mechanical stability for photovoltaic modules. The system is secured to the roof with the L-Foot components through the roofing material to building structure. Modules are secured to the racking system with aluminum clamps and aluminum splices that clamp across the gap of adjacent modules. The modules are bonded to the racking system via the clamp’s and splice’s stainless steel bonding pins. Fire ratings of Class A with Type 1, 2, 29, 30 or 38 for steep and low slope. Tested at 5" interstitial gap which allows installation at any stand-off height.

Latest SFM Install Manual revision: PUB2026JAN23

UL 2703 and TIL Mechanical Load ratings tested module area 27.76 sq ft:

Standard Configuration with Additional Mid Bays Installed	
Downward Design Load (lb/ft ²)	75
Upward Design Load (lb/ft ²)	33
Down-Slope Load (lb/ft ²)	22.2

SOLARMOUNT Flush-to-Roof is an extruded aluminum rail PV racking system that is installed parallel to the roof in landscape or portrait orientations.

Unirac Large Array is a ground mount system using the SolarMount (SM) platform for the bonding and grounding of PV modules.

Model(s)
SM, Unirac Large Array

SolarMount

The system listed is designed to provide bonding/grounding, and mechanical stability for photovoltaic modules. The system is secured to the roof with the L-Foot components through the roofing material to building structure. Modules are secured to the racking system with stainless steel or aluminum mid clamps and Aluminum end clamps. The modules are bonded to the racking system with the stainless-steel bonding mid clamps with piercing points. The system is grounded with 10 AWG copper wire to bonding/grounding lugs. Fire ratings of Class A with Type 1, 2, 3 (with metallic frame), 4 (with trim), 5 (with trim), 10(with metallic frame), 19, 22, 29, 30 or 38 for steep slope. Class A with Type 1, 2, 29, 30 or 38 for low slope. Tested at 5" interstitial gap which allows installation at any stand-off height.

The grounding of the system is intended to comply with the latest edition of the National Electrical Code, to include NEC 250 & 690. Local codes compliance is required, in addition to national codes. All grounding/bonding connections are to be torqued in accordance with the Installation Manual and the settings used during the certification testing for the current edition of the project report.

SolarMount Tilt Legs is a variation of the SolarMount system that utilizes structural standoff attachments to achieve a range of module tilt angles. The SolarMount Tilt Legs installation instructions are captured in an Installation Addendum that covers both the SolarMount Tilt Legs system and the NXT Tilt Legs

system. SolarMount Tilt Legs has mechanical load ratings independent of the SolarMount and NXT UMount mechanical load ratings.

The system may employ optimizers/micro-inverters and used for grounding when installed per installation instructions.

Latest SolarMount Install Manual revision: PUB2026JAN23

Latest SolarMount NXT Tilt Legs Installation Addendum revision: PUB2025APR25, PUB2025APR25-Trinity, PUB2025SEP26_New Logo

SolarMount UL 2703 Mechanical Load ratings:

Module Area up to 22.2 sq ft	
Downward Design Load (lb/ft ²)	113.5
Upward Design Load (lb/ft ²)	50.7
Down-Slope Load (lb/ft ²)	16.13

Module Area up to 27.12 sq ft	
Downward Design Load (lb/ft ²)	33.9
Upward Design Load (lb/ft ²)	33.9
Down-Slope Load (lb/ft ²)	16.5

Module Area up to 29.49 sq ft	
Downward Design Load (lb/ft ²)	31.18
Upward Design Load (lb/ft ²)	31.18
Down-Slope Load (lb/ft ²)	9.8

SolarMount Test Loads:

Module Area up to 22.2 sq ft	
Downward Load (lb/ft ²)	170.20
Upward Load (lb/ft ²)	76.07
Down-Slope Load (lb/ft ²)	24.2

Module Area up to 27.12 sq ft	
Downward Design Load (lb/ft ²)	50.85
Upward Design Load (lb/ft ²)	50.85
Down-Slope Load (lb/ft ²)	24.75

Module Area up to 29.49 sq ft	
Downward Design Load (lb/ft ²)	46.77
Upward Design Load (lb/ft ²)	46.77
Down-Slope Load (lb/ft ²)	14.7

SolarMount Tilt Legs UL 2703 Mechanical Load ratings:

Module Area up to 21.05 sq ft	
Downward Design Load (lb/ft ²)	50.53
Upward Design Load (lb/ft ²)	44.33
Down-Slope Load (lb/ft ²)	10.93

SolarMount Tilt Legs Test Loads:

Module Area up to 21.05 sq ft	
Downward Design Load (lb/ft ²)	75.80
Upward Design Load (lb/ft ²)	66.50
Down-Slope Load (lb/ft ²)	16.40

Unirac Large Array

Unirac Large Array is a ground mount system using the SolarMount (SM) platform for the bonding and grounding of PV modules. ULA aluminum components merge with SM rails and installer-supplied steel pipe. The SM rail system is secured to the horizontal Pipe using the Rail Bracket components. The Rear and Front cap secures the horizontal Pipe to the vertical Pipe. The Front cap is also used to secure the Cross brace. A Slider is attached to the vertical Pipe to secure the Cross brace. The SM rails, caps, slider, rail brackets, and cross braces materials are 6105-T5 aluminum extrusion. Fasteners materials are 304 stainless steel. Horizontal and vertical pipe materials meet the minimum requirements of ASTM A53 for galvanized steel pipe in 2” and 3” diameter.

The mechanical load ratings from the SM test data will be applied to the Unirac Large Array model.

Fire Testing is not applicable due to being a ground mount system.

The grounding of the system is intended to comply with the latest edition of the National Electrical Code, to include NEC 250 & 690. Local codes compliance is required, in addition to national codes. All grounding/bonding connections are to be torqued in accordance with the Installation Manual and the settings used during the certification testing for the current edition of the project report.

Latest Install Manual revision: PUB2026JAN23

SM Ascender, one or two row elevated or non elevated roof system is an extruded aluminum rail PV racking system that is installed to the roof in portrait orientation

Model(s)
SM Ascender

SM Ascender

The system listed is designed to provide bonding/grounding, and mechanical stability for photovoltaic modules. The system is secured to the roof with the L-Foot components through the roofing material to building structure. Modules are secured to the racking system with aluminum mid clamps and aluminum end clamps. Fire rating of Class A when installed over non-combustible roofing materials.

The grounding of the system is intended to comply with the latest edition of the National Electrical Code, to include NEC 250 & 690. Local codes compliance is required, in addition to national codes. All grounding/bonding connections are to be torqued in accordance with the Installation Manual and the settings used during the certification testing for the current edition of the project report.

Latest Install Manual revisions (1P Elevated, 1P Non Elevated, 2P Elevated, 2P Non Elevated): PUB2026JAN23

UL 2703 Mechanical Load ratings for tested module area 27.76 sq ft:

Downward Design Load (lb/ft ²)	28.4
Upward Design Load (lb/ft ²)	31.9
Down-Slope Load (lb/ft ²)	5.2

UL 2703 and TIL Mechanical Load ratings tested module area 27.76 sq ft:

Downward Design Load (lb/ft ²)	17.1
Upward Design Load (lb/ft ²)	17.1
Down-Slope Load (lb/ft ²)	5.2

SM Ascender Flush Mount, flush mount roof system is an extruded aluminum rail PV racking system that is installed to the roof in portrait or landscape orientation.

Model(s)
SM Ascender Flush Mount

SM Ascender Flush Mount

The system listed is designed to provide bonding/grounding, and mechanical stability for photovoltaic modules. The system is secured to the roof with the L-Foot components through the roofing material to building structure. Modules are secured to the racking system with aluminum mid clamps and aluminum end clamps. Fire ratings of Class A with Type 1, 2, 3 (with metallic frame), 10(with metallic frame), 19, 22, 25, 29, 30 or 38 for steep slope. Class A with Type 1, 2, 29, 30 or 38 for low slope. Tested at 5” interstitial gap which allows installation at any stand-off height.

The grounding of the system is intended to comply with the latest edition of the National Electrical Code, to include NEC 250 & 690. Local codes compliance is required, in addition to national codes. All grounding/bonding connections are to be torqued in accordance with the Installation Manual and the settings used during the certification testing for the current edition of the project report.

Latest Install Manual revision: PUB2026JAN23

UL 2703 Mechanical Load ratings for tested module area 27.76 sq ft:

Downward Design Load (lb/ft ²)	28.4
Upward Design Load (lb/ft ²)	31.9
Down-Slope Load (lb/ft ²)	5.2

UL 2703 and TIL Mechanical Load ratings tested module area 27.76 sq ft:

Downward Design Load (lb/ft ²)	17.1
Upward Design Load (lb/ft ²)	17.1
Down-Slope Load (lb/ft ²)	5.2

The grounding of the system is intended to comply with the latest edition of the National Electrical Code, to include NEC 250 & 690. Local codes compliance is required, in addition to national codes. All grounding/bonding connections are to be torqued in accordance with the Installation Manual and the settings used during the certification testing for the current edition of the project report.

APPLICABLE REQUIREMENTS

Standards Used	Description
CSA TIL No. A-40:20	PV Module and Panel Rack Mounting Systems and Accessories
ANSI/UL 2703:2015 - First Edition - Including revisions through June 11, 2025	UL Standard for Safety Mounting Systems, Mounting Devices, Clamping/Retention Devices, and Ground Lugs for Use with Flat-Plate Photovoltaic Modules and Panels

#enter additional notes here#

MARKINGS

The manufacturer is required to apply the following markings:

- Products shall be marked with the markings specified by the particular product standard.
- Products certified for Canada shall have all Caution and Warning markings in both English and French.

Additional bilingual markings not covered by the product standard(s) may be required by the Authorities Having Jurisdiction. It is the responsibility of the manufacturer to provide and apply these additional markings, where applicable, in accordance with the requirements of those authorities.

The products listed are eligible to bear the CSA Mark shown with adjacent indicators 'C' and 'US' for Canada and US (indicating that products have been manufactured to the requirements of both Canadian and U.S. Standards) or with adjacent indicator 'US' for US only or without either indicator for Canada only.

SM and ULA markings

The following markings appear on the rail by adhesive label:

1. Submitter’s name and/or CSA Master Contract number “266909”;
2. Model designation;
3. Manufacturing date;

The following markings appear on the Mid clamp by stamping:

1. Submitter’s name and/or CSA Master Contract number “266909”;
2. CSA mark
3. Mil ID for factory location



RM 5 South and RM DT markings

The following markings appear on the ballast bay by permanent stamping:

1. Submitter’s name and/or CSA Master Contract number “266909”;
2. Model designation;
3. Manufacturing date;

UNIRAC RM SOUTH 5
 CONFORMS TO UL STD 2703
 PATENT PENDING
 UNIRAC MFR DDDYY



SYSTEM FIRE CLASS RATING: SEE INSTALLATION INSTRUCTIONS FOR INSTALLATION REQUIREMENTS TO ACHIEVE A SPECIFIED SYSTEM FIRE CLASS RATING WITH THIS PRODUCT.

DESIGN LOAD RATING: SEE INSTALLATION INSTRUCTIONS FOR LOADS AND MODULES QUALIFIED FOR USE WITH THIS PRODUCT.

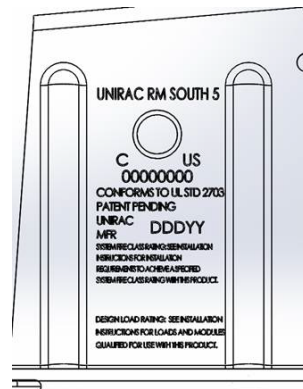

Nameplate adhesive label material approval information:

Markings applied via permanent stamping to bay.

GFT markings

The following markings appear on the rail by adhesive label:

1. Submitter's name;
2. Model designation;
3. Manufacturing date;

The following markings appear on the Mid-clamp by stamping:

4. Submitter's name and/or CSA Master Contract number "266909";
5. CSA mark
6. Mil ID for factory location



NXT UMount markings:

The following markings appear on the rail by adhesive label:

1. Submitter's name;
2. Model designation;
3. Manufacturing date;

The following markings appear on the Mid-clamp by stamping or in the extrusion profile:

4. Submitter's name and/or CSA Master Contract number "266909";
5. CSA mark
6. Mil ID for factory location (Positive or Negative Mill ID)



SM Ascender and SM Ascender Flush Mount markings

The following markings appear on the rail by adhesive label:

4. Submitter's name and/or CSA Master Contract number "266909";

5. Model designation;
6. Manufacturing date;

The following markings appear on the Mid clamp by stamping:

7. Submitter's name and/or CSA Master Contract number "266909";
8. CSA mark
9. Mil ID for factory location



GridFlex 10D markings

The following markings appear on the ballast bay by permanent stamping:

1. Submitter's name and/or CSA Master Contract number "266909";
2. Model designation;
3. Manufacturing date;

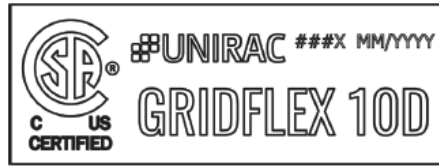

###X - Vendor ID
MM/YYYY - Month and Year of Manufacturing

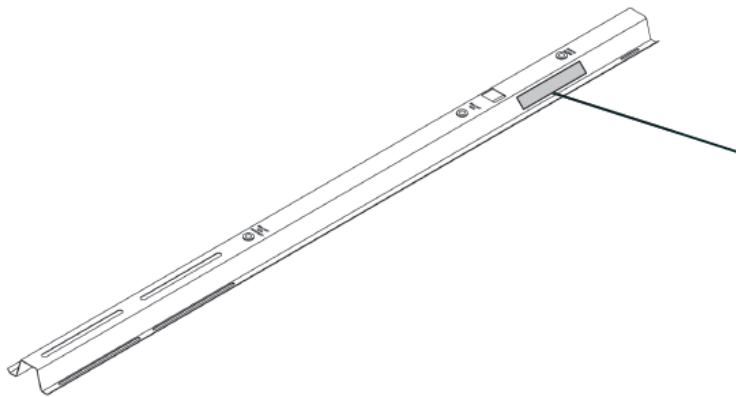

Note: North Rail has a system label at the location shown in the diagram.

EcoFoot2+ markings

The following markings appear on the wind deflector by permanent stamping or adhesive label:

1. Submitter’s name and/or CSA Master Contract number “266909”;
2. Model designation;
3. Manufacturing date;



EcoFoot5D markings

The following markings appear on the wind deflector by permanent stamping or adhesive label:

1. Submitter’s name and/or CSA Master Contract number “266909”;
2. Model designation;
3. Manufacturing date;

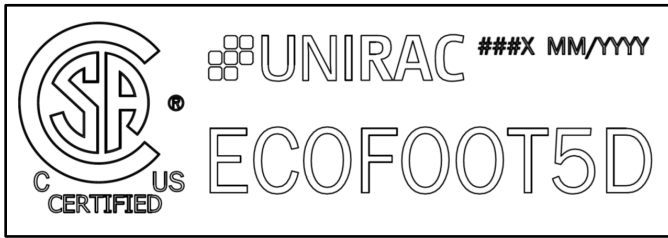

RM10 EVO markings

The following markings appear on the upright of the North Bay and Field Bay assemblies by adhesive label:

1. Submitter’s name and/or CSA Master Contract number “266909”;
2. Model designation;
3. Manufacturing date;

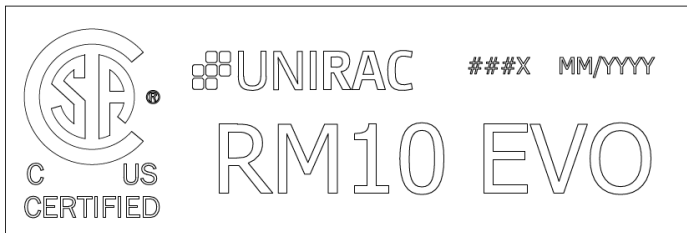

SFM (Sun Frame Microrail) markings

The following markings appear on the splice components by permanent stamping:

1. Submitter’s name and/or CSA Master Contract number “266909”;

The following markings appear on the smallest unit packaging label by adhesive label:

2. Model designation;
3. Manufacturing date;

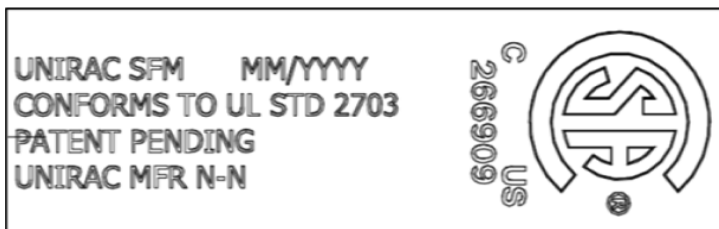

Nameplate adhesive label material approval information:

Markings applied via permanent stamping or adhesive sticker to rail.

Nameplate adhesive label material approval information:

SATO AMERICA INC, SF401 DuraMark Polyester, MH48415 - Printing Materials – Component, UL 969-Marking and Labeling Systems

ALTERATIONS

Markings, as described above appear on each unit.

FACTORY TESTS

Not Applicable

SPECIAL INSTRUCTIONS FOR FIELD SERVICES

1. Component descriptions marked with either the "(INT)" or "(INT*)" identifiers may be substituted with other components providing the requirements specified under the notes in the "Description" are complied with.
2. The critical components identified below may be formed at other locations and shipped directly to the construction site provided they are made with the material/coatings identified and conform to the physical dimensions described and shown in their respective illustrations. Physical specimens may not be present at the location where the CSA mark is applied.

COMPONENT SPECIAL PICKUP

1. Component descriptions marked with the identifier "(CT)" are subject to annual pickup and Conformity Testing.

DESCRIPTION

DESCRIPTION

Notes:

1. Component Substitution
 - a) Critical components (those identified by mfr name, cat no), which are NOT identified with either "INT" or "INT*" are not eligible for substitution without evaluation and report updating
 - b) The term "INT" means a "Certified" and/or "Listed" (or a "Recognized" and/or "Accepted") component may be replaced by one "Certified" and/or "Listed" by another certification organization accredited by the appropriate accreditation body or scheme requirements to the correct standard, for the same application; providing the applicable country identifiers are included and requirements in item "d" below are complied with.
 - c) The Term "(INT*)" means a "Recognized" and/or "Accepted" component may be replaced by a component that is CSA Certified. The applicable country identifiers shall be included, the

requirements in item "d" below as well as any "conditions of suitability" for the component (as recorded in this descriptive report) shall be complied with;

- d) Components which have been substituted, must be of an equivalent rating, configuration (size, orientation, mounting) and the applicable minimum creepage and clearance distances are to be maintained from live parts to bonded metal parts and secondary parts.
- e) Substitution of a "Certified" and/or "Listed" component with a component that is "Recognized" or "Accepted" is not permitted without evaluation and report updating.
- f) Substitution of a "Recognized" and/or "Accepted" component by one that is not CSA Certified is not permitted without a proper evaluation as well as a report update because the Conditions of Acceptance of the original component may be different than the Conditions of Acceptance of the substitute component.