

# ProPlex<sup>®</sup>

DATA DISTRIBUTION



# CodeBridge<sup>™</sup>

TIMECODE OR MIDI OVER ETHERNET

---

## USER MANUAL

TMB authorizes its customers to download and print this electronically published manual for professional use only. TMB prohibits reproduction, modification or distribution of this document for any other purposes, without express written consent.

Specifications are subject to change without notice. The information in this document supersedes all previously supplied information before the effective date listed below. TMB has confidence in the accuracy of the document information herein but assumes no responsibility or liability for any loss occurring as a direct or indirect result of errors or exclusions whether by accident or any other cause.

Effective 11 July 2025. © Copyright 2025, TMB. All rights reserved

## TABLE OF CONTENTS

Title page .....	1
Product Model .....	1
Product photos .....	1
Manual Edition notice, copyright, disclaimer .....	1
Table of contents.....	2
Overview.....	4
Model Description .....	4
Main Features.....	4
Ordering Codes.....	4
Model Overview .....	5
Full dimensional wireframe drawings.....	6
Setup.....	7
Safety Precautions .....	7
Unpacking .....	7
What's included.....	8
Power requirements .....	8
Installation.....	9
Mounting overview .....	9
RackMount Installation instructions.....	9
Installing the Dual Joiners.....	11
Operation .....	12
Home Screens.....	12
Main Menu .....	13
Timecode Generator.....	13
Output Level.....	14
Pre-roll Frames .....	14
Post-roll Frames.....	14
IP Address .....	15
Device Name .....	15
Device Information.....	16
Firmware Information .....	16

---

Menu Map .....	17
LED Status Indicators .....	18
Web Browser.....	19
Firmware Updates.....	20
Cleaning and Maintenance.....	21
Technical Specifications .....	21
Limited Warranty Information.....	22
Return Procedure.....	23
Contact information.....	24

The ProPlex CodeBridge is a member of our LTC Device system which is designed to generate, distribute and monitor timecode. Our rugged, compact mini-enclosure design is perfect for desktop programmers to throw in bag while also being flexible enough to install in a rack with an optional RackMount Kit. Drop a CodeBridge anywhere you need to share a fully synchronized timecode stream between multiple departments and other TMB LTC devices on the network.

## MAIN FEATURES

- Theoretically unlimited number of CodeBridges possible on the same network
- OLED control panel with intuitive user interface and LTC clock, oscilloscope, and level display
- Remote access and configuration via ProPlex Software GUI\* or built-in web page
- Interface options include the ability to name and select between multiple CodeBridge sources\*
- Two transformer-isolated XLR3 LTC outputs. Adjustable output level (-18dBu to +6dBu)
- Front panel status LEDs for Ethernet, MIDI and LTC
- Compact, lightweight, rugged, reliable. Backpack friendly
- Available rackmount kit options
- Redundant power - USB-C and PoE

\*RTP MIDI, ProPlex Software functionality and naming and selecting of sources will be added in future firmware updates

## ORDERING CODES

PART NUMBERS	PROUDCT NAME
PPCODEBLME	PROPLEX CODEBRIDGE
PP1RMKITSS	1U RACKMOUNT KIT, SMALL, SINGLE
PP1RMKITSD	1U RACKMOUNT KIT, SMALL, DUAL
PP1RMKITS+MD	PROPLEX 1U DUAL COMBINATION SMALL + MEDIUM

### MODEL OVERVIEW

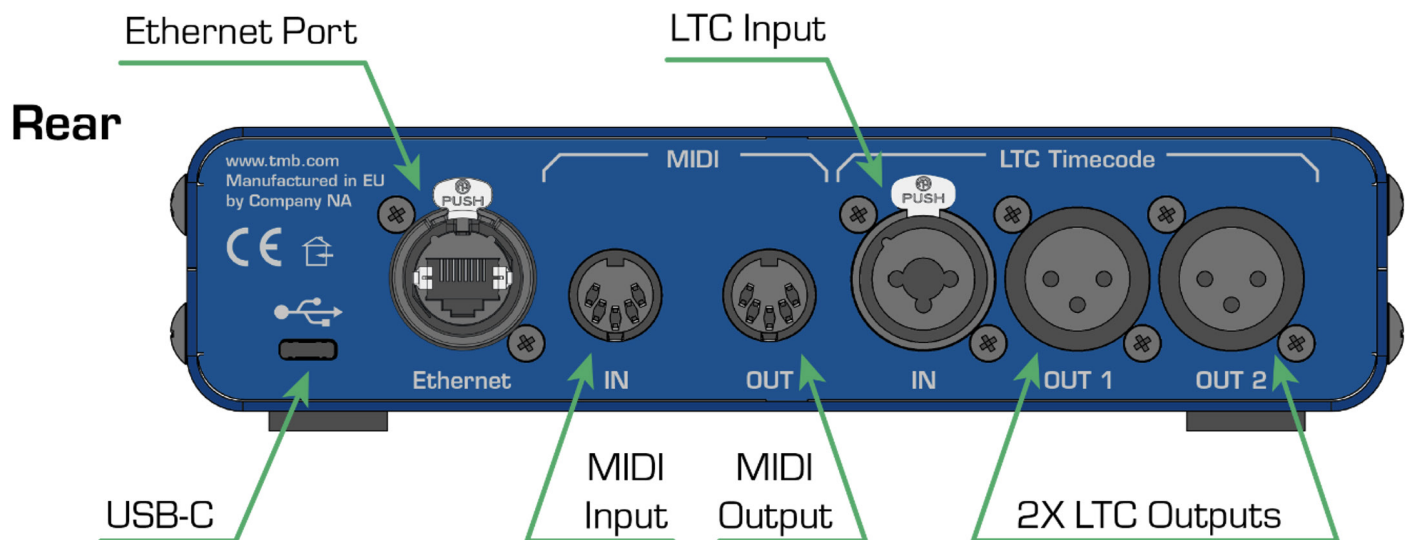
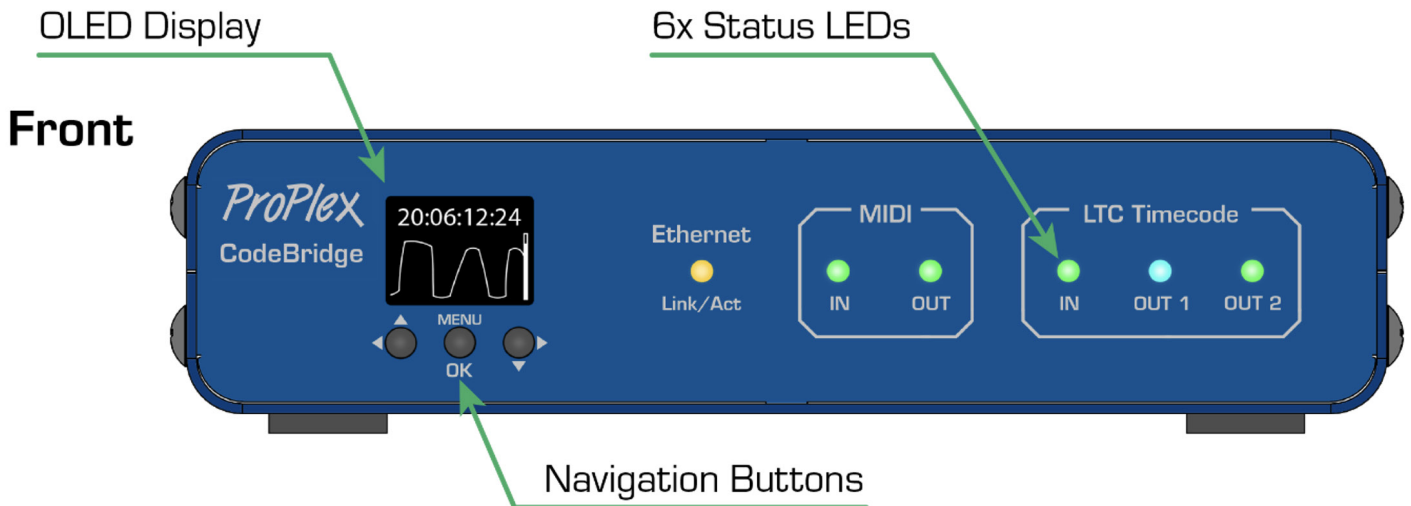

### FULL DIMENSIONAL WIREFRAME DRAWINGS

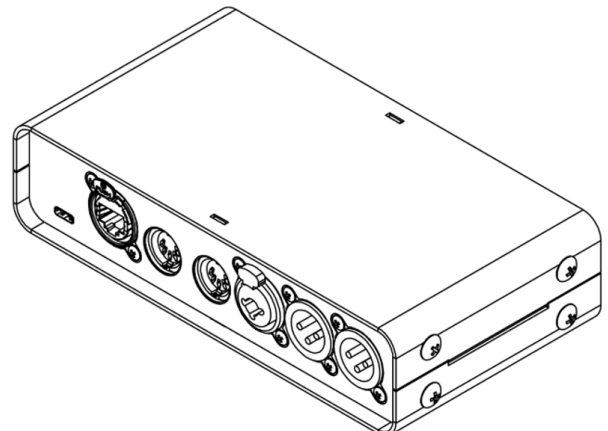
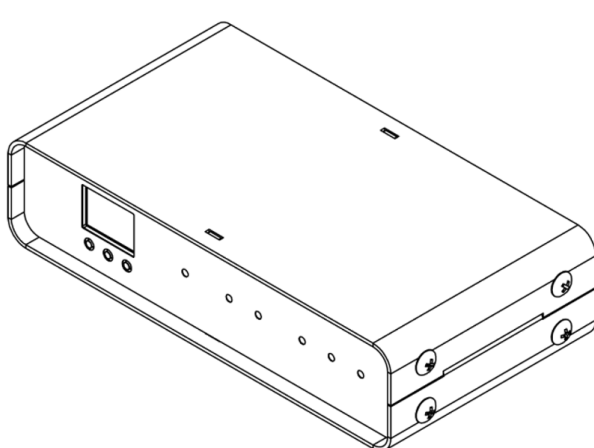
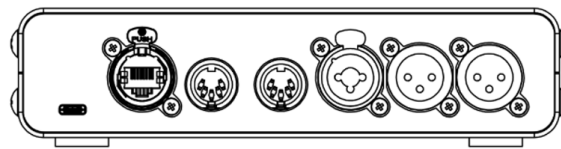
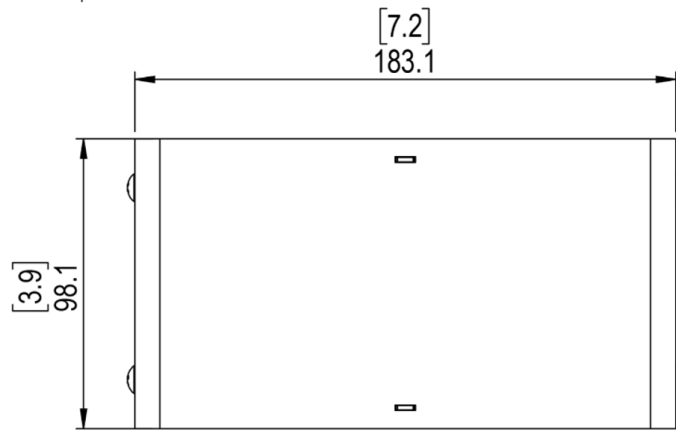
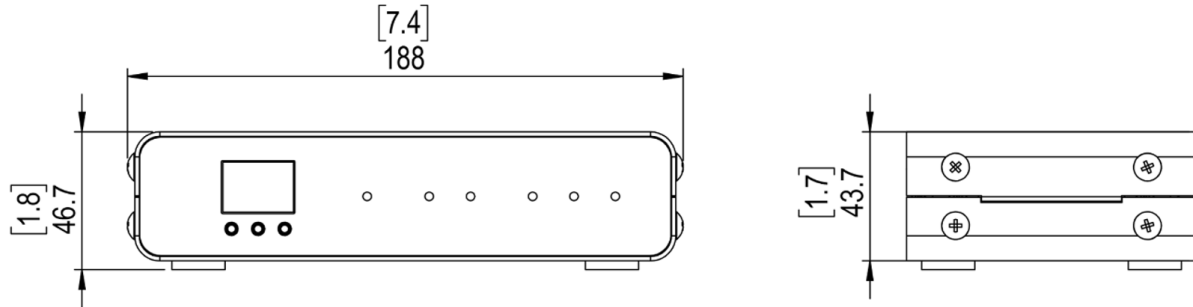

## SETUP

### Safety Precautions



**Please read these instructions carefully. This user guide contains important information about the installation, usage, and maintenance of this product**

- Ensure the device is connected to proper voltage, and that line voltage is not higher than that stated in the device specifications
- Make sure there are no flammable materials close to the unit while operating
- Always use a safety cable when hanging fixture overhead
- Always disconnect from the power source before servicing or fuse replacement (if applicable)
- Maximum ambient temperature (Ta) is 40°C (104°F). Do not operate unit at temperatures above this rating
- In the event of a serious operating problem, stop using the unit immediately. Repairs must be carried out by trained, authorized personnel. Contact the nearest authorized technical assistance center. Only OEM spare parts should be used
- Do not connect the device to a dimmer pack
- Make sure power cord is never crimped or damaged
- Never disconnect power cord by pulling or tugging on the cord



**CAUTION! There are no user serviceable parts inside the unit. Do not open the housing or attempt any repairs yourself. In the unlikely event your unit may require service, please see the limited warranty information at the end of this document**

## UNPACKING

Upon receipt of the unit, carefully unpack the carton and check the contents to ensure that all parts are present and in good condition. Notify the shipper immediately and retain packing material for inspection if any parts appear to be damaged from shipping or if the carton itself shows signs of mishandling. Save the carton and all packing materials. If a unit must be returned to the factory, it is important that it be returned in the original factory box and packing.

### WHAT'S INCLUDED

- ProPlex CodeBridge
- USB-C Cable
- Cable retainer clamp
- QR Code downloads card

### POWER REQUIREMENTS

The ProPlex CodeBridge has redundant power connections.

- Power the device via a USB-C cable connected to any standard 5 VDC wall charger or computer USB port
- Supply Power over Ethernet (PoE) by connecting the CodeBridge Ethernet port to any PoE enabled switch or injector.

In some cases, you may want to utilize both connections. Units powered via PoE allow access to the web browser via any computer connected to the same network. Additionally, all connected CodeBridge devices will share stream data via Ethernet. USB-C connections allow for MTC data communication as well as power-IN.

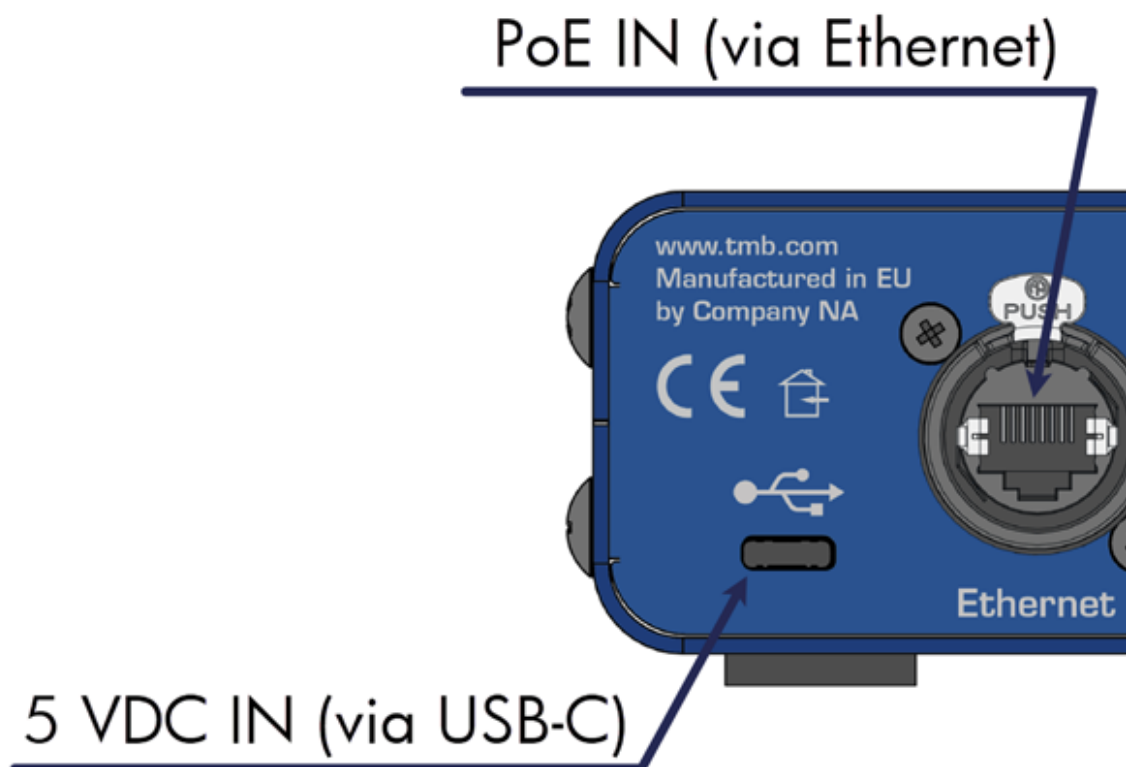

## INSTALLATION

The ProPlex CodeClock enclosure was designed with the touring programmer in mind. We wanted these devices to be lightweight, packable and stackable – so we fitted them with oversized rubber feet to keep them stationary on most surfaces

These units are also compatible with Small RackMount Kits should they need to be semi-permanently mounted for touring applications

## RACKMOUNT INSTALLATION INSTRUCTIONS

ProPlex RackMount Kits are available for both Single-Unit and Dual-Unit mounting configurations

To fasten the rack ears or joiners to the ProPlex PortableMount chassis, you must remove the two chassis screws on each side at the front of the chassis. These same screws are used to securely fasten the RackMount ears and joiners to the chassis

For dual-unit configurations, both sets of front and rear chassis screws will be used

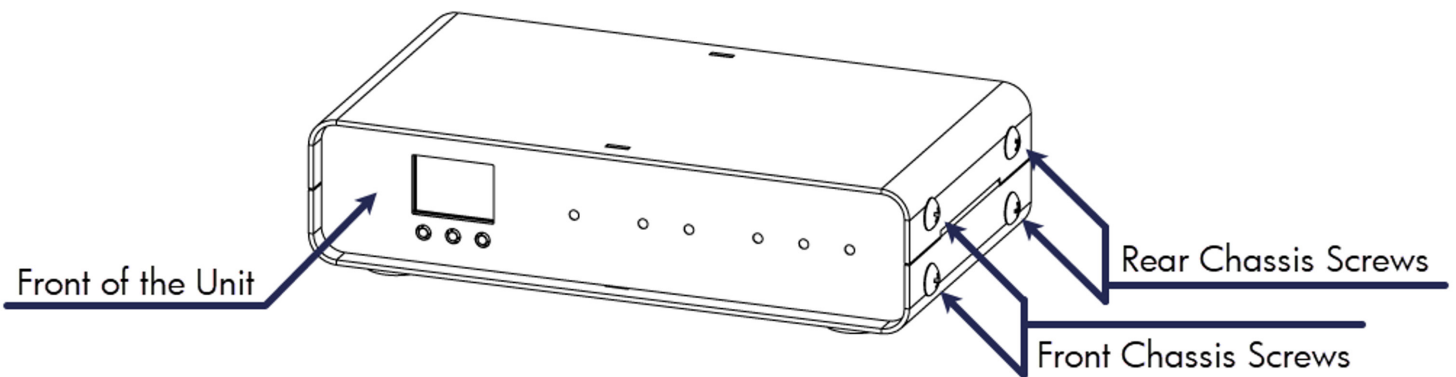

**IMPORTANT :** Be sure to reinsert the screws into the unit after ears have been removed. Store RackMount Kit in a safe location until needed again. Spare screws are available from TMB if needed

### RACKMOUNT INSTALLATION INSTRUCTIONS

The Single-Unit Small RackMount Kit is comprised of two rack ears, ONE long and ONE short. The diagram below depicts the completed installation of the RackMount Kit. These rack ears are designed to be symmetrical, so that the short and long ears can be interchangeable

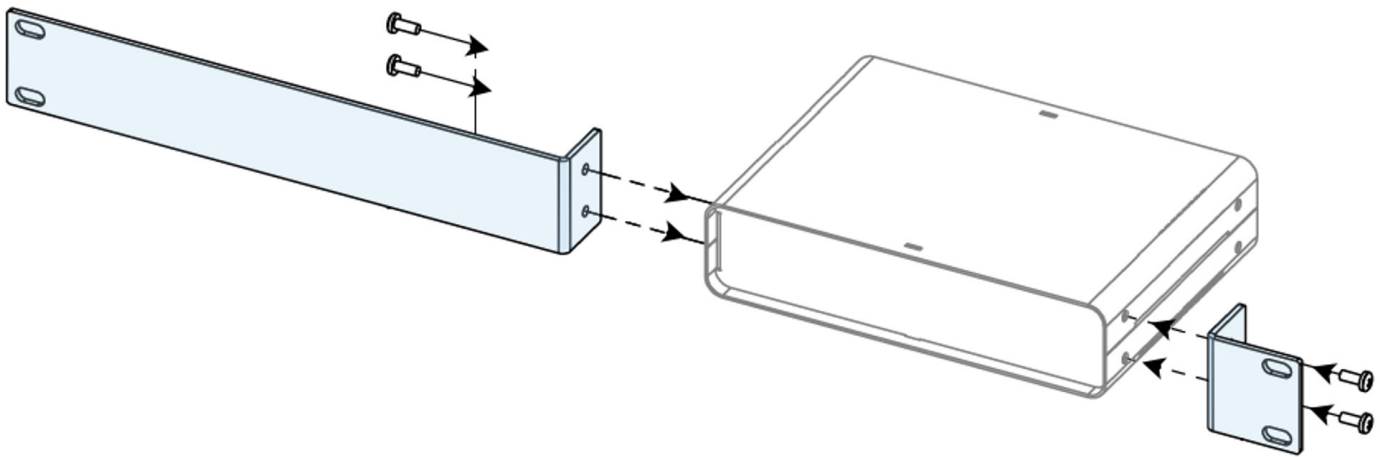

The Dual-Unit Small RackMount Kit has TWO short rack ears plus TWO joiners. The diagram below depicts the completed installation of the RackMount Kit. This configuration requires the TWO center joiners attached at both front and rear

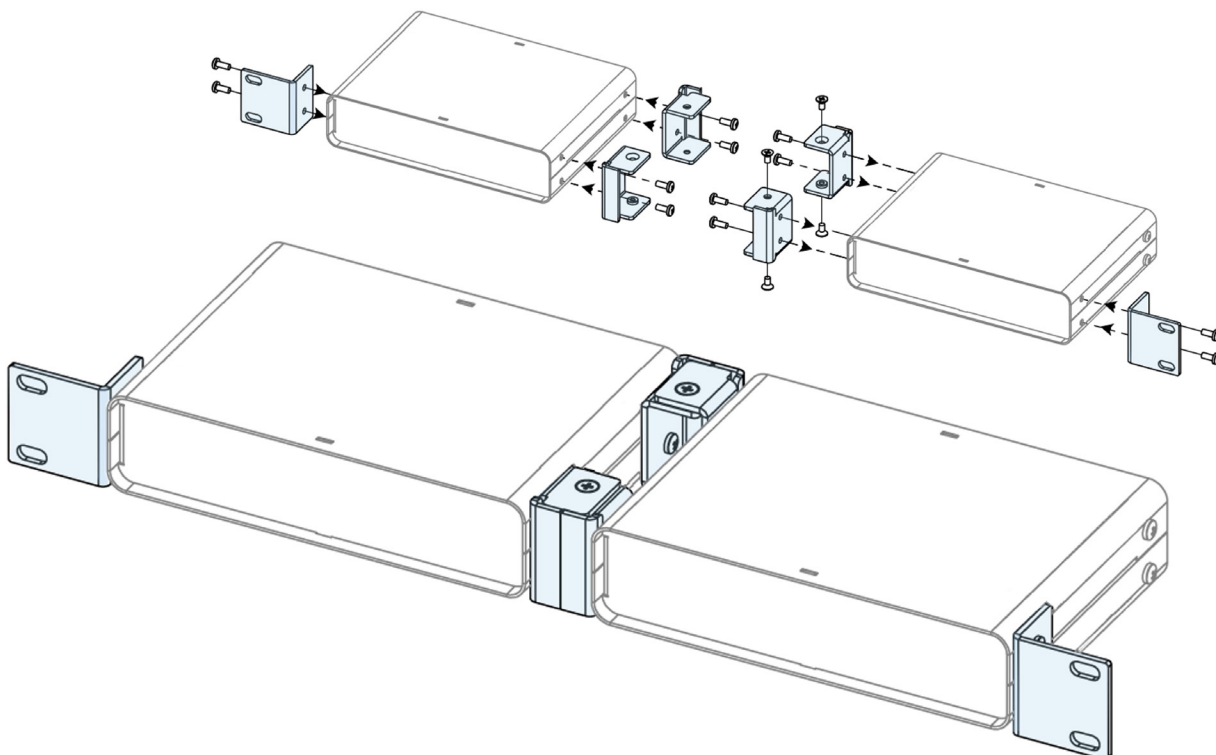

## INSTALLING THE DUAL JOINERS

The Dual-Unit Small RackMount Kit includes FOUR joining links and FOUR countersunk flat head screws. These links are designed to nest into each other and are secured with the included screws and threaded holes.

Each link piece is identical. Simply rotate the joining link and line up the installation holes to install on either the left or right side of the corresponding unit.

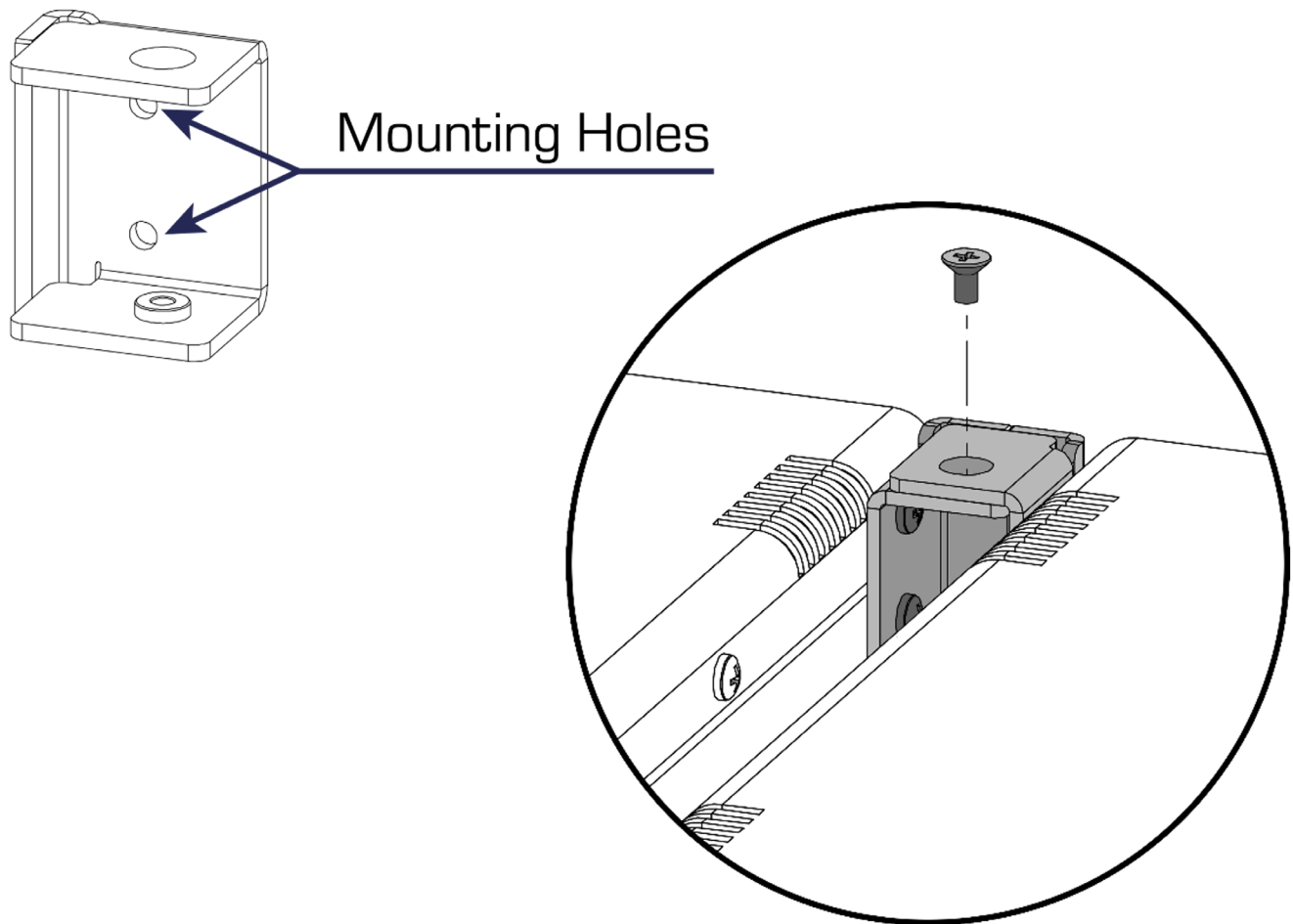

### OPERATION

The ProPlex CodeBride can be easily configured with the onboard OLED Display and navigation buttons on the front of the unit

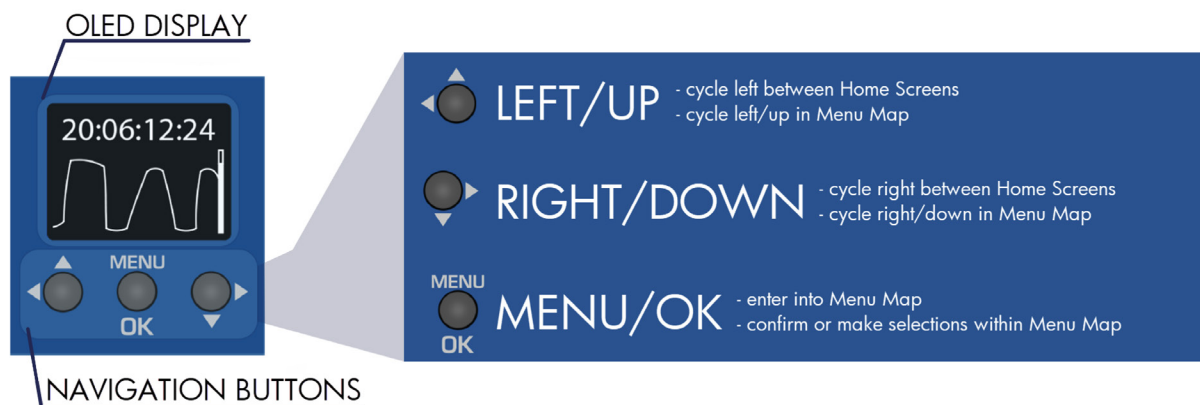

### HOME SCREENS

The CodeBridge has 3 separate HOME SCREENS that display different parameters of incoming timecode streams. Cycle between these screens by pressing either the ◀ or ▶ button

#### Home Screen 1

The incoming LTC IN stream is displayed at the top of the screen while the bottom area shows oscillogram and voltage level bar to indicate signal level from the LTC source only

Note: Ideally the LTC IN steam should resemble a square wave with high output level. If level is too low, try increasing the volume at the source to improve the signal

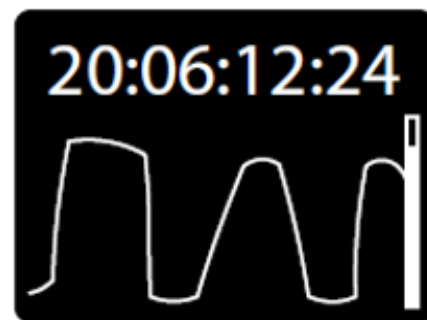

#### Home Screen 2

This screen displays all sources of timecode that the CodeBridge can detect

The topmost source is the current active source which is retransmitted further from output connections. Whichever source is active will be highlighted with a blinking background

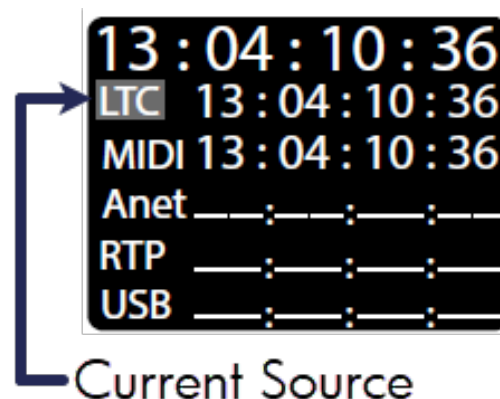

### Home Screen 3

The third screen displays format information on all detected streams

Like Home Screen 2, the top-most source is the current active source which is retransmitted further from output connections. Whichever source is active will be highlighted with a blinking background

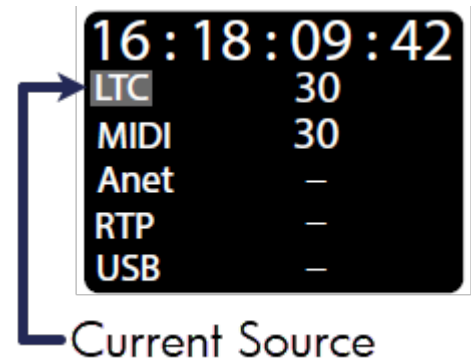

### Main Menu

The Main Menu can be accessed by pressing the  button and majority of options can be exited via the  button

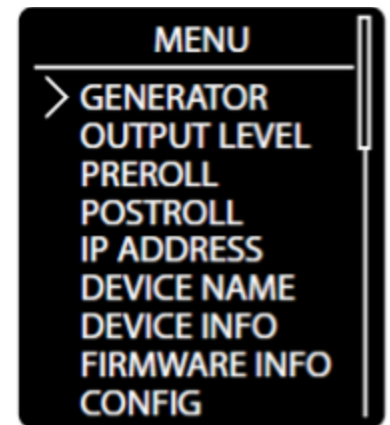

Scroll with the  or  button and confirm selection with the  button.

Note: Not all menus will fit on the device screen so you will need to scroll to access some menus. The right side of most menu screens will display a scroll bar which will help indicate the depth of scroll navigation



### Timecode Generator

The CodeBridge can generate clean, high output LTC out of the two isolated XLR3 ports (located on the rear of each unit)

Use the  or  button, then confirm selection with the  button to cycle between the various generator options

**Format:** Select between different industry standard FPS rates 23.976, 24, 25, 29.97ND, 29.97DF, and 30 FPS. If the selected format is compatible with MTC or Art-Net timecode, it will also be transmitted through that respective interface port (MIDI OUT or Ethernet ports)

**Start Time:** Specify a start time of HH:MM:SS:FF using navigation buttons

**User Data:** Specify user data in 0x00000000 hex format

**Play, Pause, Rewind:** User playback controls for generated timecode.

*Note: you must remain on this screen to continuously use the LTC generator. If you exit this screen, the generator will stop automatically, and the current source will change over to the next active source*

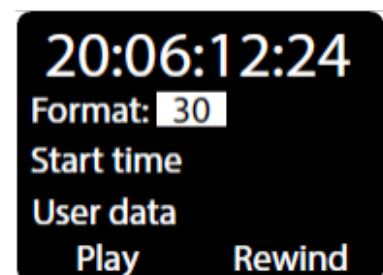

### Output Level

Boost or cut the output level from +6 dBu to -12 dBu. Everything outputting via the two isolated XLR3 ports is affected by this level change. This includes:

- Generator output
- Re-transmitted timecode formats from other inputs

Use the ◀ or ▶ button, then confirm selection with the  button to cycle between the various output levels. The asterisk indicator will denote the currently selected output level

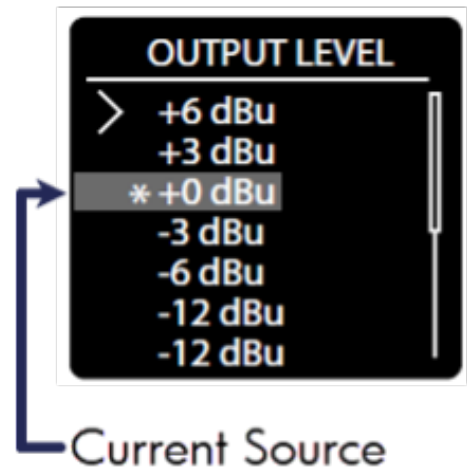

### Pre-roll Frames

Pre-roll is the number of valid frames needed to consider the timecode source to be valid and begin forwarding it to the outputs

Use the ◀ button to highlight the Pre-roll value, then press  button to edit

Use the ◀ or ▶ button to set the Pre-roll frames (1-30) and  to save the value

*Note: The active stream display will always show incoming LTC stream starting from the 1st received frame regardless of Pre-roll settings*

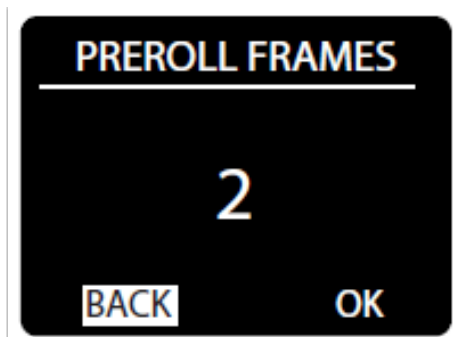



### Post-roll Frames

Post-roll frames help correct erroneous or dropped frames in a timecode source

When a stream is stopped for any reason, the transmission will continue until a count equivalent to the Post-roll frames setting is reached

If an erratic source issue resolved within the Post-roll window, the device will continue streaming timecode without interruption

Use the ▶ button to highlight the Post-roll value, then press  button to edit. Use ▶ to select a value place in HH:MM:SS:FF format



Press  button to edit each value as needed, using ◀ or ▶ to change the count. Press  after editing to save each value and repeat to edit the next.









### IP Address

View or set the IP Address and Netmask of the unit

Note: This is the address used to access the CodeBridge Web Browser. This is mainly used to monitor and update each unit with future firmware releases



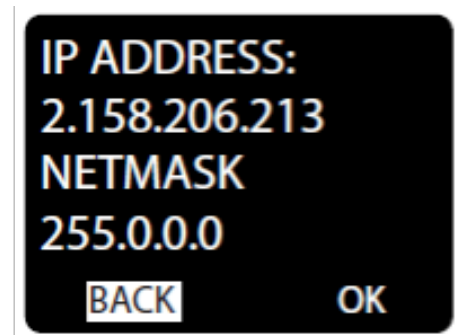

Use the  or  button to highlight, then press  button to edit either IP Address or Netmask



Use  or  to select a value in x.x.x.x format. Press  to edit, using  or  to change each value and  again to save. Repeat to edit each octet



### Device Name

Create a custom name for the device

-  Backspace
-  Change to UPPERCASE
-   Move the cursor
- 123** Number editor
  -  Add a space

Use  or  to select and highlight an editing tool or a letter, then press to confirm selection

Highlight the 123 menu and press  to input a numerical character.

Use  or  to select 0-9 and press  again to confirm selection and type the character in the name field

When name editing is complete, highlight OK and press  to save and exit



### Device Information

Device Info displays status information of the unit.  
The information displayed is:

**Device Name**

**IP Address**

**NetMask**

**MAC Address**

Press  to exit

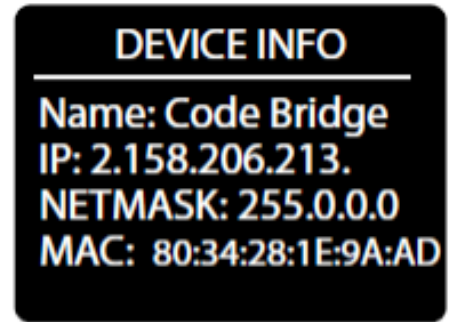

### Firmware Information

Firmware Info displays status information of the unit.  
The information displayed is

**Version Number**

**Build date**

**Build time**

Press  to exit



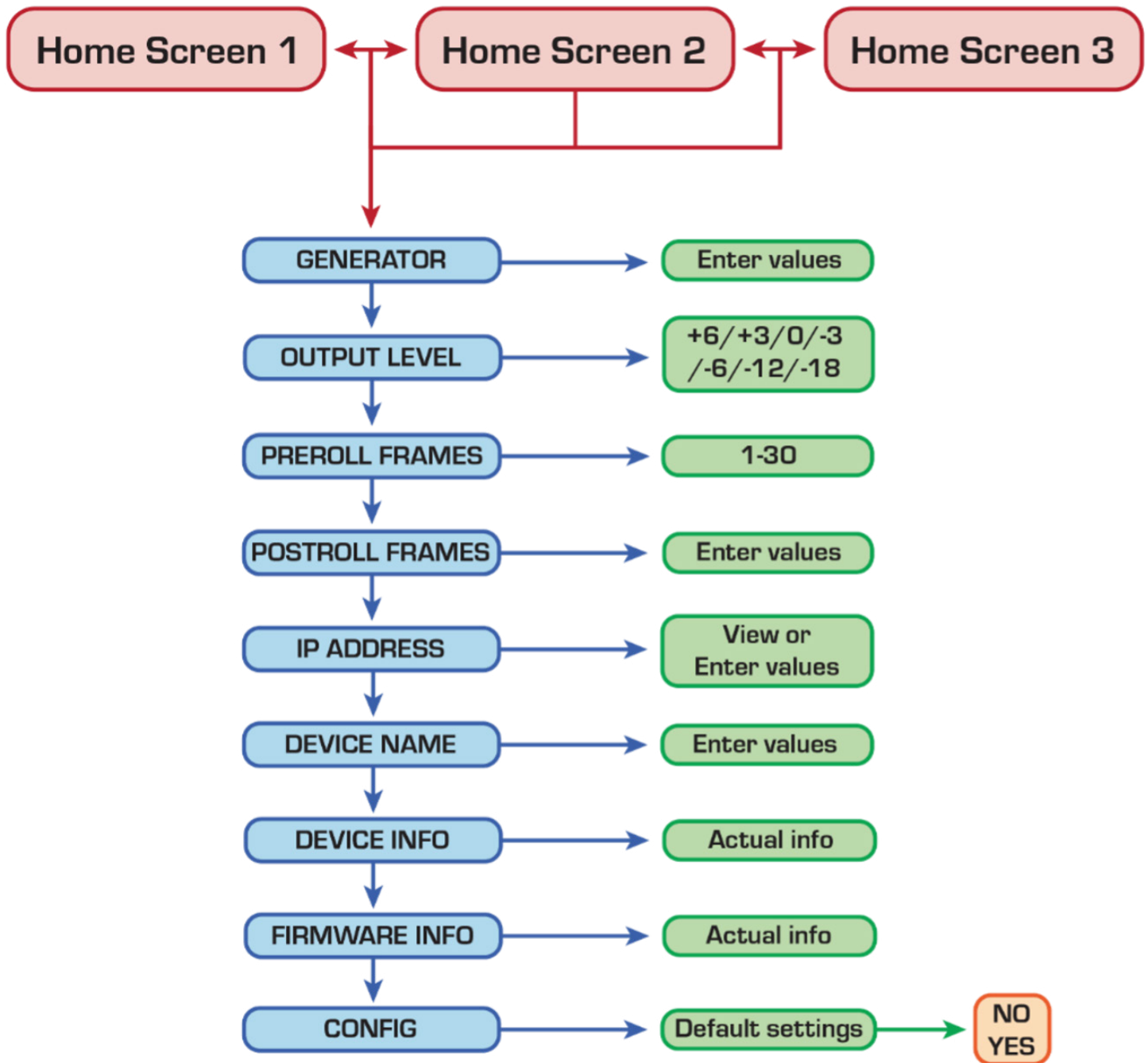

## MENU MAP





## LED STATUS INDICATORS



### MIDI IN:

-  Receives timecode
-  Receives data which is not timecode





### MIDI OUT:

-  Transmits timecode from source
-  Transmits timecode, postroll is running
-  Transmits data which is not timecode

### LTC IN:

-  Receives timecode, but 1 second has not passed without errors or jumps in timecode
-  Receives timecode without jumps or errors for more than 1 second
-  Timecode was received, but is not received at the moment

### LTC OUT:

-  Transmits timecode, postroll is running
-  Transmits timecode, internal generator is running
-  Transmits timecode for more than 1 second
-  Transmits timecode, but 1 second has not passed from start of transmission

### WEB BROWSER

Any networked computer can access the CodeBridge Web Browser

Locate the IP address of the unit (instructions above) then type the IP address into the address bar of your favorite browser. You should be presented with the following landing page:

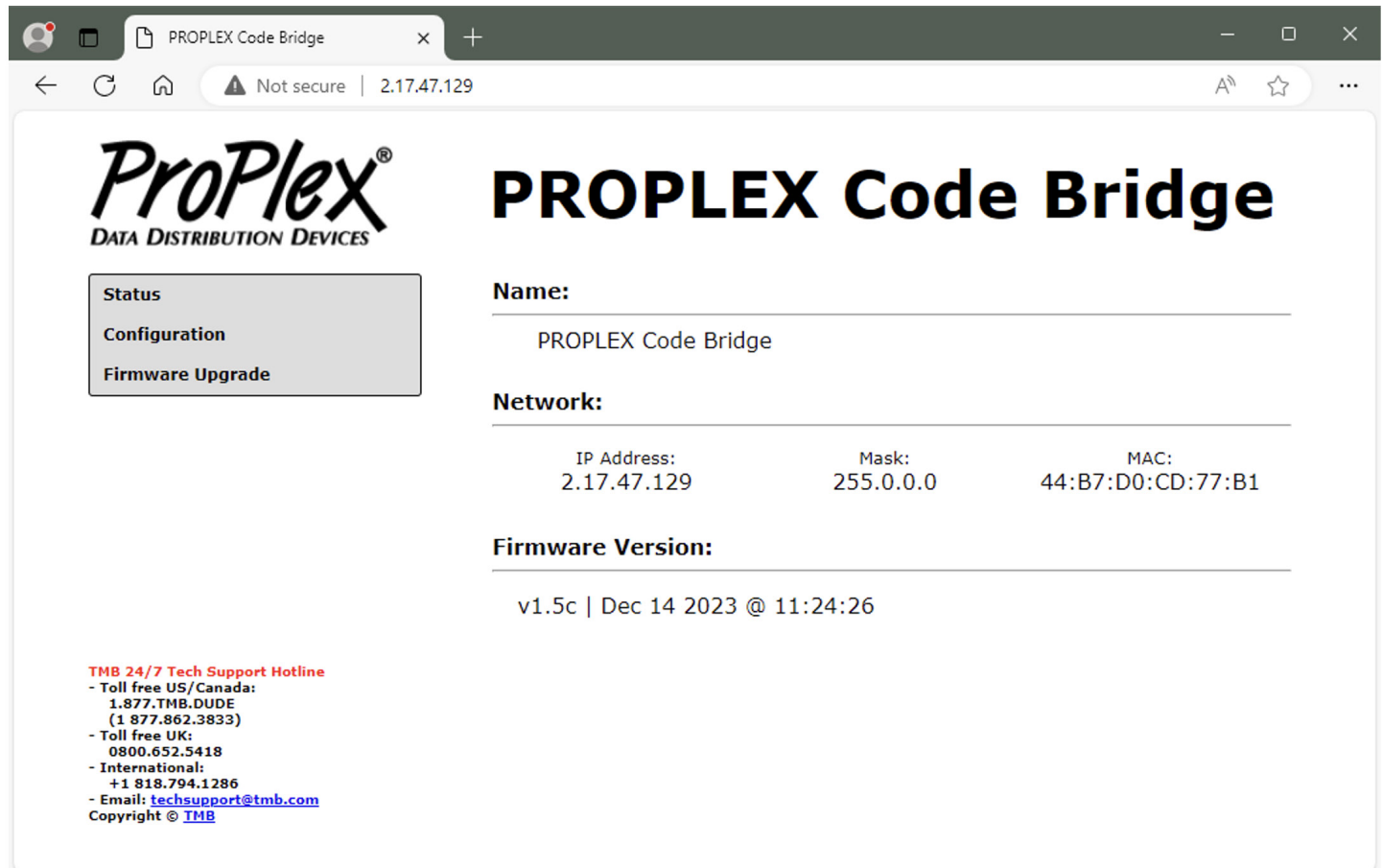

Note: computer or laptop should be in the same network range - 2.X.X.X

### FIRMWARE UPDATES

Occasionally we will release firmware updates that contain new features or bug fixes. Firmware for all ProPlex units is available via the TMB Cloud

A link to TMB Cloud is under the Resources menu on our main website <https://tmb.com/>

To update, download the new firmware.bin file to your desktop. Then upload through the “Firmware Upgrade” menu via the Web Browser



## CLEANING AND MAINTENANCE

Dust build-up in connector ports can cause performance issues and can potentially lead to further damage during normal wear and tear

CodeClock devices need occasional cleaning to maintain best performance, especially units used in harsher environmental conditions

### THE FOLLOWING ARE GENERAL CLEANING GUIDELINES:

- Always disconnect from power before attempting any cleaning
- Wait until unit has cooled and discharged completely before cleaning
- Use vacuum or dry compressed air to remove dust/debris in and around connectors
- Use a soft towel or brush to wipe and buff the chassis body
- To clean the navigation screen, apply isopropyl alcohol with a soft lens cleaning tissue or lint free cotton
- Alcohol pads and q-tips may help remove any grime and residue from navigation buttons



**IMPORTANT:**  
Be sure all surfaces are dry before attempting to power on again

## TECHNICAL SPECIFICATIONS

Part Number	PPCODEBLME
Power Connector	USB-C
Ethernet (& PoE in) Connector	Neutrik EtherCON <sup>™</sup> RJ45
MIDI Input Connector	DIN 5-Pin Female
MIDI Output Connector	DIN 5-Pin Female
LTC Input Connector	Neutrik <sup>™</sup> Combination 3-Pin XLR and 1/4" TRS female
LTC Output Connectors	Neutrik <sup>™</sup> 3-Pin XLR Male
Operating Voltage	5 VDC USB-C or 48 VDC PoE
Power Consumption	TBA
Operating Temp.	TBA
Dimensions (HxWxD)	1.72 x 7.22 x 4.42 in [43.7 x 183.5 x 112.3 mm]
Weight	1.2 lbs. [0.54 kg]
Shipping Weight	1.4 lbs. [0.64 kg]

## LIMITED WARRANTY INFORMATION

ProPlex Data Distribution Devices are warranted by TMB against defective materials or workmanship for a period of two (2) years from the date of original sale by TMB.

TMB's warranty shall be restricted to the repair or replacement of any part that proves to be defective and for which a claim is submitted to TMB before the expiration of the applicable warranty periods.

This Limited Warranty is void if the defects of the Product are the result of:

- Opening the casing, repair, or adjustment by anyone other than TMB or persons specifically authorized by TMB
- Accident, physical abuse, mishandling, or misapplication of the product.
- Damage due to lightning, earthquake, flood, terrorism, war, or act of God.

TMB will not assume responsibility for any labor expended, or materials used, to replace and/or repair the Product without TMB's prior written authorization. Any repair of the Product in the field, and any associated labor charges, must be authorized in advance by TMB. Freight costs on warranty repairs are split 50/50: Customer pays to ship defective product to TMB; TMB pays to ship repaired product, ground freight, back to Customer.

This warranty does not cover consequential damages or costs of any kind.

A Return Merchandise Authorization (RMA) Number must be obtained from TMB prior to return of any defective merchandise for warranty or non-warranty repair. For repair enquiries, please contact TMB via email at [TechSupport@tmb.com](mailto:TechSupport@tmb.com) or phone at either of our locations below:

### **TMB US**

527 Park Ave.  
San Fernando, CA 91340  
United States  
Tel: +1 818.899.8818

### **TMB UK**

21 Armstrong Way  
Southall, UB2 4SD  
England  
Tel: +44 (0)20.8574.9700

You may also contact TMB directly via email at [TechSupport@tmb.com](mailto:TechSupport@tmb.com)

## RETURN PROCEDURE

Please contact TMB and request a repair ticket and Return Merchandise Authorization Number prior to shipping items for repair. Be prepared to provide the model number, serial number, and a brief description of the cause for the return as well as the return shipping address and contact information. Once a repair ticket has been processed, the RMA # and return instructions will be sent via email to the contact on file.

Clearly label any shipping package(s) with **ATTN: RMA#**. Please return equipment prepaid and in the original packaging whenever possible. **DO NOT** include cables or accessories (unless advised otherwise). If original packaging is not available, be sure to properly pack and protect any equipment. TMB is not liable for any shipping damage resulting from inadequate packaging by the sender.

Freight call tags will not be issued for shipping repairs to TMB, but TMB will pay the freight for return to the customer if the repair qualifies for warranty service. Non-warranty repairs will undergo a quotation process by the technician assigned to the repair. All associated costs for parts, labor and return shipping must be authorized in writing before any work can be completed.

TMB reserves the right to use its own discretion to repair or replace product(s) and determine the warranty status of any equipment.

## CONTACT INFORMATION

### **LOS ANGELES HEADQUARTERS**

527 Park Avenue | San Fernando, CA 91340, USA

Tel: +1 818.899.8818 | Fax: +1 818.899.8813

[sales@tmb.com](mailto:sales@tmb.com)

### **TMB 24/7 TECH SUPPORT**

US/Canada: +1.818.794.1286

Toll Free: 1.877.862.3833 (1.877.TMB.DUDE)

UK: +44 (0)20.8574.9739

Toll Free: 0800.652.5418

[techsupport@tmb.com](mailto:techsupport@tmb.com)

LOS ANGELES +1 818.899.8818

LONDON +44 (0)20.8574.9700

NEW YORK +1 201.896.8600

BEIJING +86 10.8492.1587

CANADA +1 519.538.0888

RIGA +371 6389 8886



[www.proplex.com](http://www.proplex.com)

A full service company providing technical support, customer service, and follow-up.

Providing products and services for the industrial, entertainment, architectural, installation, defense, broadcast, research, telecommunications, and signage industries.

Servicing the global market from offices in Los Angeles, London, New York, Toronto, Riga and Beijing.