

A suite of timecode functions: receive, transmit, analyze, reshape, generate
Supports multiple protocols with all industry standard rates and formats
Many In – Primary Out : converts primary input to all available outputs
Take advantage of existing networking infrastructure by adding multiple CodeBridges to distribution drop points



Features

- Primary Source conversion – any input can be elected as “primary” and forwarded to the outputs
- Automatic failover – if a source is lost, the next input is promoted to primary
- Distribute timecode through a theoretically unlimited number of CodeBridges on the network
- Assign StreamID to transmitted streams and filter incoming streams
- OLED control panel with intuitive user interface, input monitors and LTC oscilloscope
- Remote access and LTC scope via ProPlex Software GUI*
- Assign CodeBridge names to help distinguish between units on the same network*
- Two transformer-isolated XLR3 LTC outputs. Adjustable output level (-18 dBu to +9 dBu)
- Front panel status LEDs for Ethernet, MIDI and LTC
- Compact, lightweight, rugged, reliable. Backpack friendly
- Available rackmount kit and yoke options
- Redundant power – USB-C and PoE

Receive and send timecode over:

- Ethernet (Art-Net TC)
- LTC (SMPTE)
- DIN-5 MIDI (MTC)
- USB MIDI (MTC)
- rtpMIDI*

* rtpMIDI, ProPlex Software functionality and multiple unit selection/navigation will be added in future firmware updates

Worldwide Exclusive Distribution



Los Angeles
+1 818.899.8818

London
+44 (0)20.8574.9700

New York
+1 201.896.8600

tmb
www.ProPlex.com

Toronto
+1 519.538.0888

Beijing
+86 10.8492.1587

Riga
+371 6389 8886

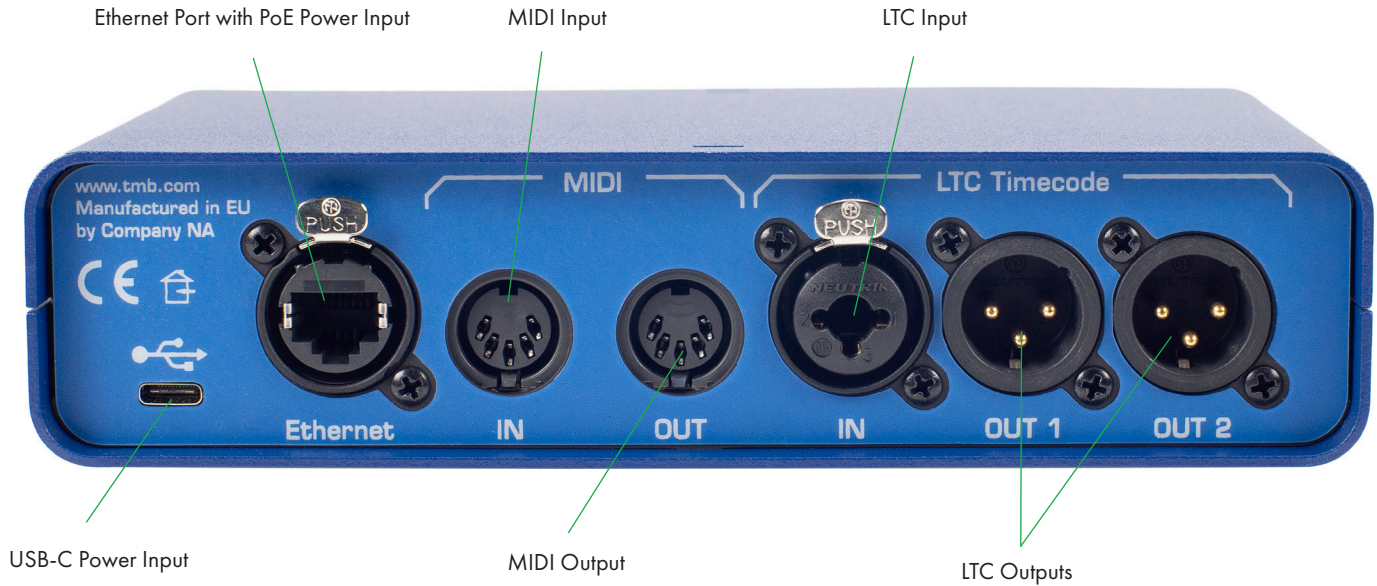

Specifications

Part Number	PPCODEBLME
Ethernet (& PoE in) Connector	Neutrik EtherCON™ RJ45
MIDI Input Connector	DIN 5-Pin Female
MIDI Output Connector	DIN 5-Pin Female
LTC Input Connector	Neutrik™ Combination 3-Pin XLR and 1/4" TRS female
LTC Output Connectors	Neutrik™ 3-Pin XLR Male
Operating Voltage	5 VDC USB-C or 48 VDC PoE
Power Consumption	TBA
Power Connector	USB-C
Operating Temp.	TBA
Dimensions (HxWxD)	1.72 x 7.22 x 4.42 in [43.7 x 183.5 x 112.3 mm]
Unit Weight	1.2 lbs. [0.54 kg]
Shipping Weight	1.4 lbs. [0.64 kg]

Los Angeles
+1 818.899.8818

London
+44 (0)20.8574.9700

New York
+1 201.896.8600

tmb
www.ProPlex.com
sales@tmb.com

Toronto
+1 519.538.0888

Beijing
+86 10.8492.1587

Riga
+371 6389 8886

Timecode Flowchart

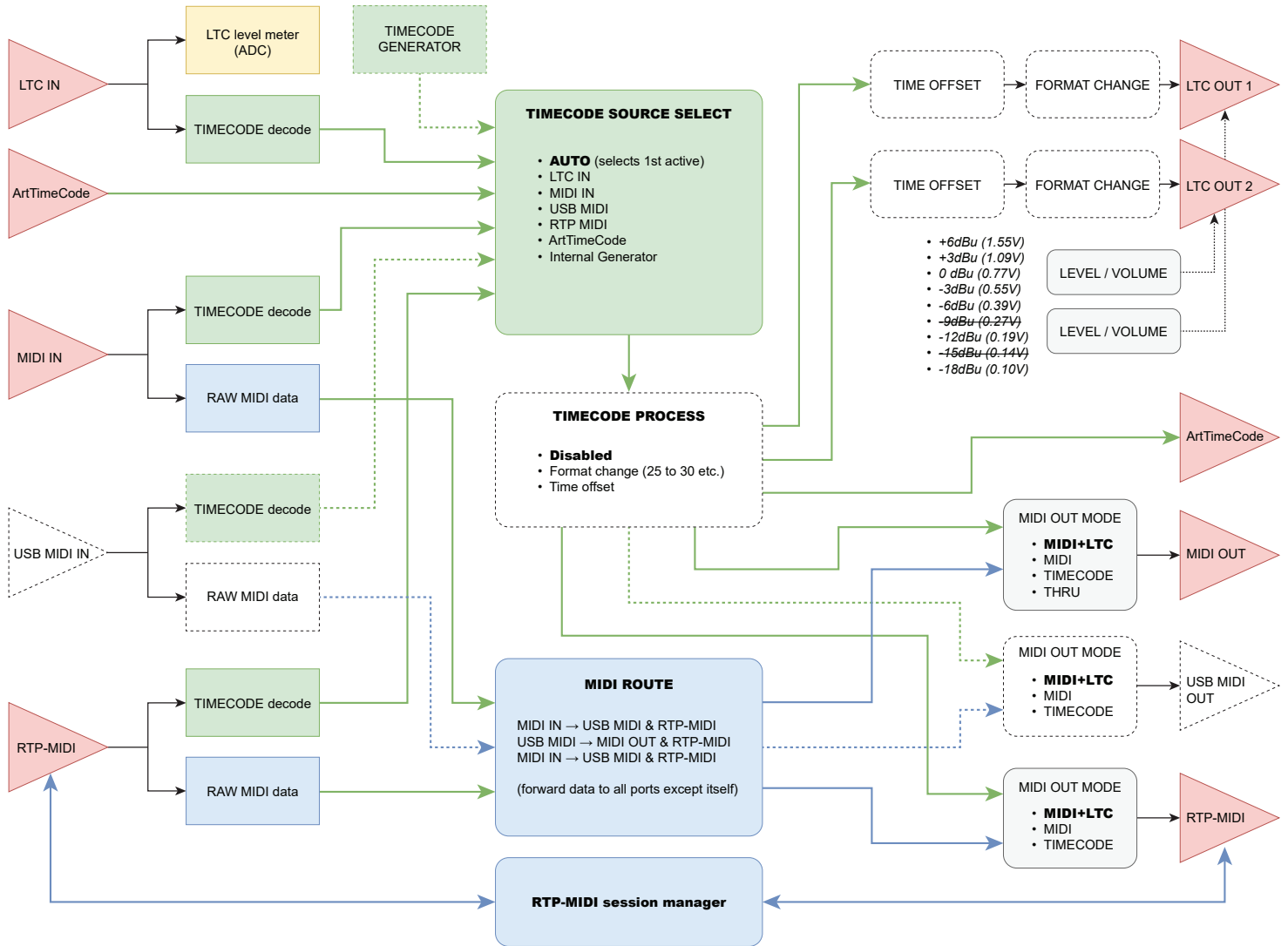

Dimensions

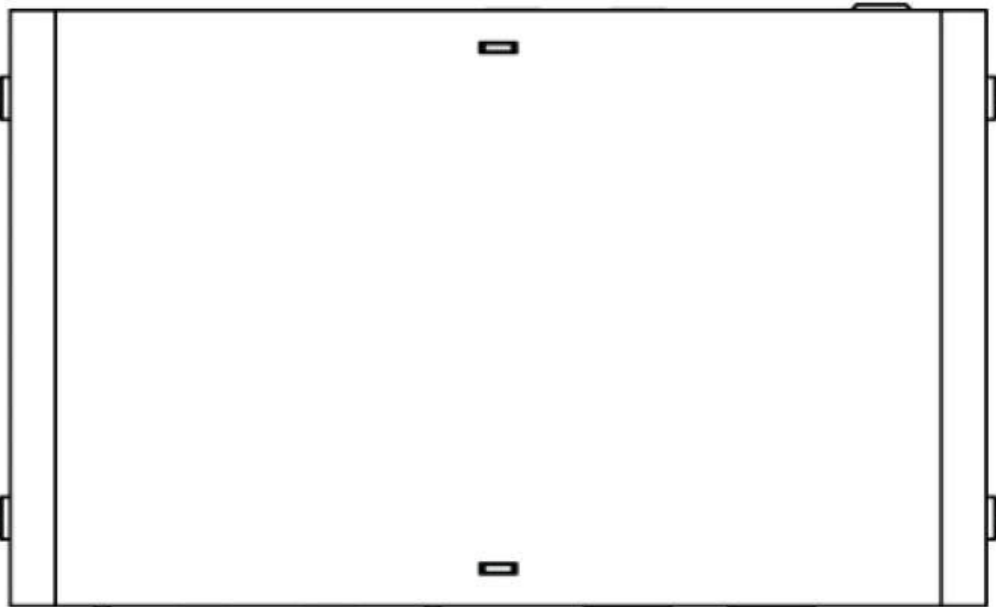
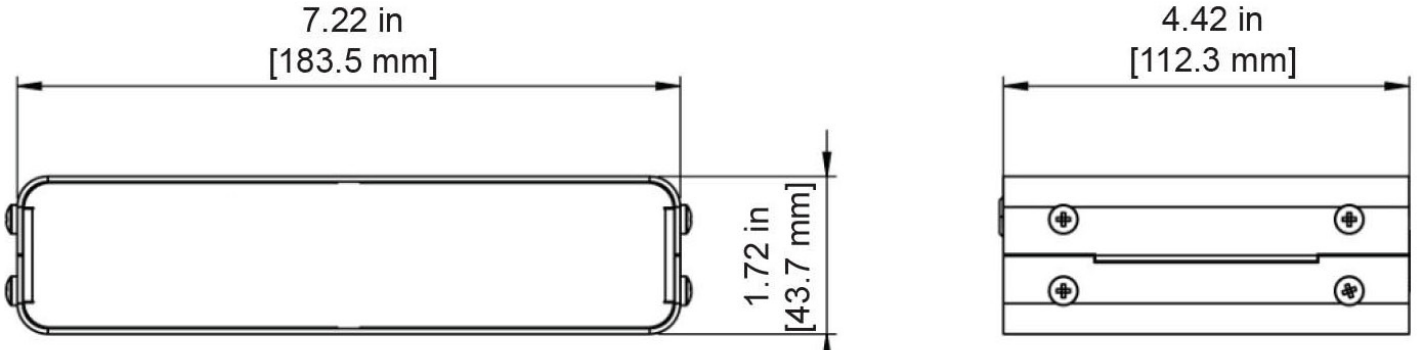

Optional RackMount Kits

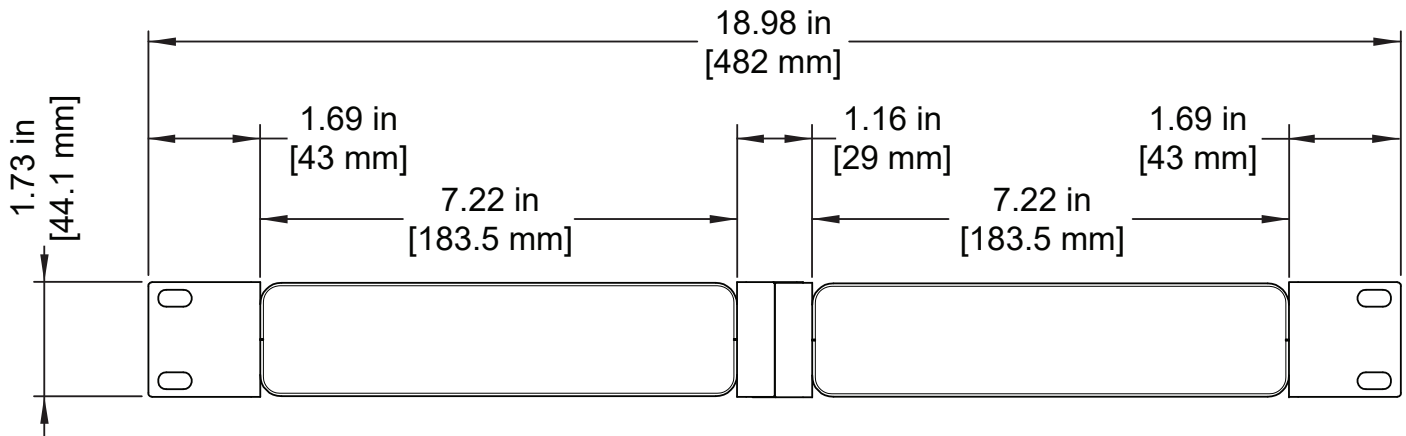
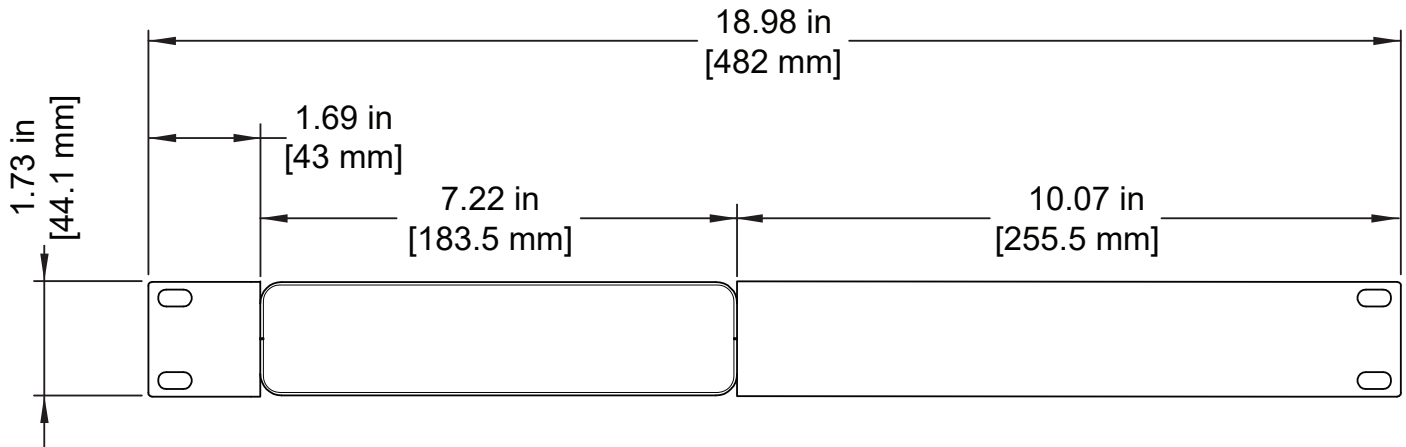

Ordering Codes

PPCODEBLME	CodeBridge LTC-MIDI-Ethernet
PP1RMKITSS	1U RackMount Kit, Small, Single
PP1RMKITSD	1U RackMount Kit, Small, Dual
PP1RMKITS+MD	1U Dual combination Small+Medium



ProPlex LTC Network System

**Timecode and/or MIDI wherever you need them!
Unlimited Ethernet distribution of LTC and MIDI
opens a world of possibilities**

CodeCommander™ Powerful multi-purpose timecode processor provides timecode conversion, generation, re-generation, configuration, repair, monitoring, plus source/output selection and management of an entire ProPlex LTC network



CodeCommander Part Number
PPCODECOMLMER
proplex.com/codecommander

*Please refer to cut-sheet for full list of features

Fully compatible with industry standard timecode protocols:

- Ethernet - Art-Net Timecode
- MIDI timecode (MTC) via USB-C and DIN-5
- SMPTE timecode (LTC) via balanced XLR ports

Convert and distribute the primary timecode source over 12 balanced LTC outputs

- 4x XLR3 outputs built-in (base model)
- Optional interchangeable panels with 8x outputs and different connector options: (DB-25, CPC, 1/4" Jacks)
- Signal shape regeneration and jitter reduction
- Output level adjustment up to +6dBu (independent for XLR and optional panels)
- 4 user-configurable preset buttons which trigger source selection modes
- Large RGB LED dot-matrix clock displays primary source and timecode generator with customizable color or default colour status scheme

CodeBridge™ Timecode and MIDI transmission/reception over Ethernet



CodeBridge Part Number
PPCODEBLME
proplex.com/codebridge

- Primary Source conversion – any input can be elected as “primary” and forwarded to the outputs
- Automatic failover – if a source is lost, the next input is promoted to primary
- Distribute timecode through a theoretically unlimited number of CodeBridges on the network
- Assign StreamID to transmitted streams and filter incoming streams
- OLED control panel with intuitive user interface, input monitors and LTC oscilloscope
- Remote access and LTC scope via ProPlex Software GUI*
- Assign CodeBridge names to help distinguish between units on the same network*
- Two transformer-isolated XLR3 LTC outputs. Adjustable output level (-18 dBu to +9 dBu)
- Front panel status LEDs for Ethernet, MIDI and LTC
- Compact, lightweight, rugged, reliable. Backpack friendly
- Available rackmount kit and yoke options
- Redundant power – USB-C and PoE



CodeClock™ Compact timecode display with LTC/MIDI/USB conversion and LTC distribution



- Large RGB LED matrix clock displays time and changes color depending on status
- Receives timecode over LTC (XLR3), MIDI (DIN), or USB MIDI
- Redistributes selected timecode over LTC outputs
- 3x Neutrik XLR3 outputs are transformer-isolated and have adjustable level (-18dBu to +6dBu)
- OLED control panel with intuitive user interface, and waveform display
- Built-in timecode generator capable of running at any standard framerate
- Compact, lightweight, rugged, reliable. Backpack friendly
- Available rackmount kit options
- Powered via USB-C. Cable retainer prevents accidental disconnection



CodeClock Part Number
PPCODECLME
proplex.com/codeclock

ProPlex LTC tools for programmers

FoH Friend™ Timecode/Audio Switching Tools

Work with your local timecode and audio track files every spare minute, until the stage calls!



- Available with and without built-in USB-C DAC
- Instantly switch between two timecode and audio sources
- All the outputs and controls you need for programming with timecode and audio tracks
- Independent gain controls for XLR audio output + true headphone amp with 1/4" and 3.5mm jacks
- Two audio + two timecode inputs all with combination XLR/TRS connectors
- Selector switches for independent selection of audio + timecode inputs
- DAC can input and output via USB simultaneously
- Backpack friendly units ship complete with carrying pouch



Original FoH Friend Part Number **PPFOHF** FoH Friend DAC Part Number **PPFOHFDAC**
proplex.com/foh-friend-timecode-audio-switching-tool

CONTACT INFORMATION

LOS ANGELES HEADQUARTERS

527 Park Avenue | San Fernando, CA 91340, USA

Tel: +1 818.899.8818 | Fax: +1 818.899.8813

sales@tmb.com

TMB 24/7 TECH SUPPORT

US/Canada: +1.818.794.1286

Toll Free: 1.877.862.3833 (1.877.TMB.DUDE)

UK: +44 (0)20.8574.9739

Toll Free: 0800.652.5418

techsupport@tmb.com

LOS ANGELES +1 818.899.8818

LONDON +44 (0)20.8574.9700

NEW YORK +1 201.896.8600

BEIJING +86 10.8492.1587

CANADA +1 519.538.0888

RIGA +371 6389 8886



www.tmb.com

A full service company providing technical support, customer service, and follow-up. Providing products and services for the industrial, entertainment, architectural, installation, defense, broadcast, research, telecommunications, and signage industries. Servicing the global market from offices in Los Angeles, London, New York, Toronto, Riga and Beijing.