



Preliminary

RF2196

3V PCS LINEAR POWER AMPLIFIER

2
POWER AMPLIFIERS

Typical Applications

- 3V CDMA PCS Handsets
- 3V CDMA KPCS Handsets
- 3V TDMA/GAIT PCS Handsets
- 3 V CDMA 2000 PCS Handsets
- Spread-Spectrum Systems
- Portable Battery-Powered Equipment

Product Description

The RF2196 is a high-power, high-efficiency linear amplifier IC targeting 3V handheld systems. The device is manufactured on an advanced Gallium Arsenide process, and has been designed for use as the final RF amplifier in 3V CDMA and CDMA2000 handsets as well as other applications in the 1750MHz to 1910MHz band. The RF2196 has a low power mode to extend battery life under low output power conditions. The package is an ultra small 4mmx4mm leadless plastic package with backside ground.

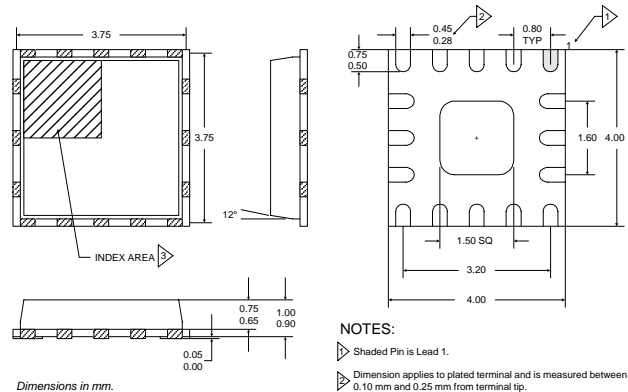

- NOTES:
- ▷ Shaded Pin is Lead 1.
 - ▷ Dimension applies to plated terminal and is measured between 0.10 mm and 0.25 mm from terminal tip.
 - ▷ The terminal #1 identifier and terminal numbering convention shall conform to JEDEC 95-1 SPP-012. Details of terminal #1 identifier are optional, but must be located within the zone indicated. The identifier may be either a mold or marked feature.
 - 4 Pins 1 and 9 are fused.
 - 5 Package Warpage: 0.05 max.

Optimum Technology Matching® Applied

- Si BJT
- GaAs HBT
- GaAs MESFET
- Si Bi-CMOS
- SiGe HBT
- Si CMOS

Package Style: LCC, 16-Pin, 4 x 4

- Features
- Single 3V Supply
 - 29dBm Linear Output Power
 - 35% Linear Efficiency
 - Low Power Mode (Up to 20dBm)
 - 55mA Idle Current

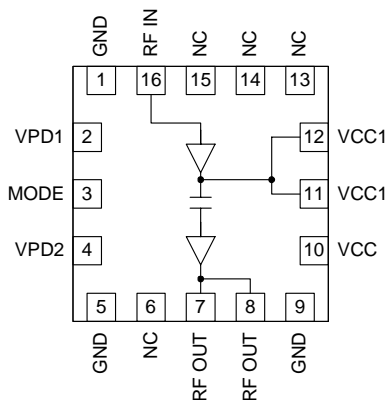

Functional Block Diagram

Ordering Information

RF2196	3V PCS LINEAR Power Amplifier
RF2196 PCBA	Fully Assembled Evaluation Board

RF Micro Devices, Inc.
7625 Thorndike Road
Greensboro, NC 27409, USA

Tel (336) 664 1233
Fax (336) 664 0454
<http://www.rfmd.com>

Absolute Maximum Ratings

Parameter	Rating	Unit
Supply Voltage (RF off)	+8.0	V _{DC}
Supply Voltage (P _{OUT} ≤31dBm)	+5.2	V _{DC}
Mode Voltage (V _{MODE})	+4.2	V _{DC}
Control Voltage (V _{REG})	+3.0	V _{DC}
Input RF Power	+10	dBm
Operating Case Temperature	-30 to +110	°C
Storage Temperature	-30 to +150	°C
Moisture Sensitivity	Modified JEDEC Level 2	



Caution! ESD sensitive device.

RF Micro Devices believes the furnished information is correct and accurate at the time of this printing. However, RF Micro Devices reserves the right to make changes to its products without notice. RF Micro Devices does not assume responsibility for the use of the described product(s).

Parameter	Specification			Unit	Condition
	Min.	Typ.	Max.		
High Power State (V _{MODE} Low)					Case T=25°C, V _{CC} =3.4V, V _{REG} =2.85V, V _{MODE} =0V to 0.5V, Freq=1850MHz to 1910MHz (unless otherwise specified)
Frequency Range	1850		1910	MHz	
Linear Gain	25	27		dB	
Second Harmonic		-50		dBc	
Third Harmonic		-63		dBc	
Maximum Linear Output Power (CDMA Modulation)	29			dBm	
Total Linear Efficiency		35		%	P _{OUT} =29dBm
Adjacent Channel Power Rejection		-46	-44	dBc	ACPR @ 1.25MHz
		-62	-56	dBc	ACPR @ 2.25MHz
Input VSWR		<2:1			
Output VSWR			10:1		No damage.
			6:1		No oscillations. >-70dBc
Noise Power		-141		dBm/Hz	At 80MHz offset.
Low Power State (V _{MODE} High)					Case T=25°C, V _{CC} =3.4V, V _{REG} =2.85V, V _{MODE} =2V to 3V, Freq=1850MHz to 1910MHz (unless otherwise specified)
Frequency Range	1850		1910	MHz	
Linear Gain	16	20		dB	
Second Harmonic		-45		dBc	
Third Harmonic		-60		dBc	
Maximum Linear Output Power (CDMA Modulation)	16	20		dBm	
Max I _{CC}		160		mA	P _{OUT} =+16dBm (all currents included)
Adjacent Channel Power Rejection		<-50	-46	dBc	ACPR @ 1.25MHz
		<-60	-58	dBc	ACPR @ 2.25MHz
Input VSWR		2:1			
Output VSWR			10:1		No damage.
			6:1		No oscillations. >-70dBc

Parameter	Specification			Unit	Condition
	Min.	Typ.	Max.		
High Power State CDMA 2000 1x (V_{MODE} LOW)					
Frequency Range	1850		1910	MHz	Case T=25°C, V _{CC} =3.4V, V _{REG} =2.85V, V _{MODE} =0V to 0.5V, Freq=1850MHz to 1910MHz (unless otherwise specified)
Linear Gain		27		dB	
Pilot+DCCH 9600					
Maximum Linear Output Power (CDMA 2000 Modulation)	26.5			dBm	
Adjacent Channel Power Rejection		-49		dBc	
		-61		dBc	
Pilot+FCH 9600+SCH0 9600					
Maximum Linear Output Power (CDMA 2000 Modulation)	29			dBm	
Adjacent Channel Power Rejection		-46		dBc	
		-63		dBc	
Low Power State CDMA 2000 1x (V_{MODE} HIGH)					
Frequency Range	1850		1910	MHz	Case T=25°C, V _{CC} =3.4V, V _{REG} =2.85V, V _{MODE} =2V to 3V, Freq=1850MHz to 1910MHz
Linear Gain		19		dB	
Pilot+DCCH 9600					
Maximum Linear Output Power (CDMA 2000 Modulation)	16	20		dBm	
Adjacent Channel Power Rejection		-52		dBc	
		-65		dBc	
Pilot+FCH 9600+SCH0 9600					
Maximum Linear Output Power (CDMA 2000 Modulation)	16	20		dBm	
Adjacent Channel Power Rejection		-52		dBc	
		-65		dBc	
DC Supply					
Supply Voltage	3.0	3.4	4.2	V	V _{MODE} =Low
Quiescent Current		185		mA	
		55		mA	V _{MODE} =High
V _{REG} Current		5	10	mA	V _{REG} =Low
V _{MODE} Current			1	mA	
Total Current (Power Down)			10	µA	
V _{REG} "Low" Voltage	0		0.5	V	
V _{REG} "High" Voltage	2.75	2.85	2.95	V	
V _{MODE} "Low" Voltage	0		0.5	V	
V _{MODE} "High" Voltage	2.0		3.0	V	

Pin	Function	Description	Interface Schematic
1	GND	This pin is internally grounded to the die flag.	
2	VREG1	Power Down control for first stage. Regulated voltage supply for amplifier bias. In Power Down mode, both V_{REG} and V_{MODE} need to be LOW (<0.5V).	
3	MODE	For nominal operation (High Gain Mode), V_{MODE} is set LOW. When set HIGH, the driver and final are dynamically scaled to reduce the device size and as a result to reduce idle current.	
4	VREG2	Power Down control for the second stage. Regulated voltage supply for amplifier bias. In Power Down mode, both V_{REG} and V_{MODE} need to be LOW (<0.5V).	
5	GND	Connect to ground plane via 15nH inductor. DC return for the second stage bias circuit.	
6	NC	This pin has no internal bonding; therefore, this pin can be connected to output pin 7, connected to the ground plane, or not connected. Slight tuning of the output match may be required due to stray capacitance of the pin.	
7	RF OUT	RF output and power supply for final stage. This is the unmatched collector output of the second stage. A DC block is required following the matching components. The biasing may be provided via a parallel L-C set for resonance at the operating frequency of 1710MHz to 1910MHz. It is important to select an inductor with very low DC resistance with a 1A current rating. Alternatively, shunt microstrip techniques are also applicable and provide very low DC resistance. Low frequency bypassing is required for stability.	
8	RF OUT	Same as pin 7.	See pin 7.
9	GND	This pin is internally grounded to the die flag.	
10	VCC	Supply for bias reference and control circuits. High frequency bypassing may be necessary.	
11	VCC1	Power supply for first stage and interstage match. Pins 11 and 12 should be connected by a common trace where the pins contact the printed circuit board.	
12	VCC1	Same as pin 11.	
13	NC	It is recommended that these pins be connected to the ground plane for improved isolation between RF IN (pin 16) and the VCC1 pins (pins 11 and 12).	
14	NC	It is recommended that these pins be connected to the ground plane for improved isolation between RF IN (pin 16) and the VCC1 pins (pins 11 and 12).	
15	NC	It is recommended that these pins be connected to the ground plane for improved isolation between RF IN (pin 16) and the VCC1 pins (pins 11 and 12).	
16	RF IN	RF input. An external 15pF series capacitor is required as a DC block. In addition, the matching circuit shown is required to improve input VSWR.	
Pkg Base	GND	Ground connection. The backside of the package should be soldered to a top side ground pad which is connected to the ground plane with multiple vias. The pad should have a short thermal path to the ground plane.	

Application Schematic US - CDMA

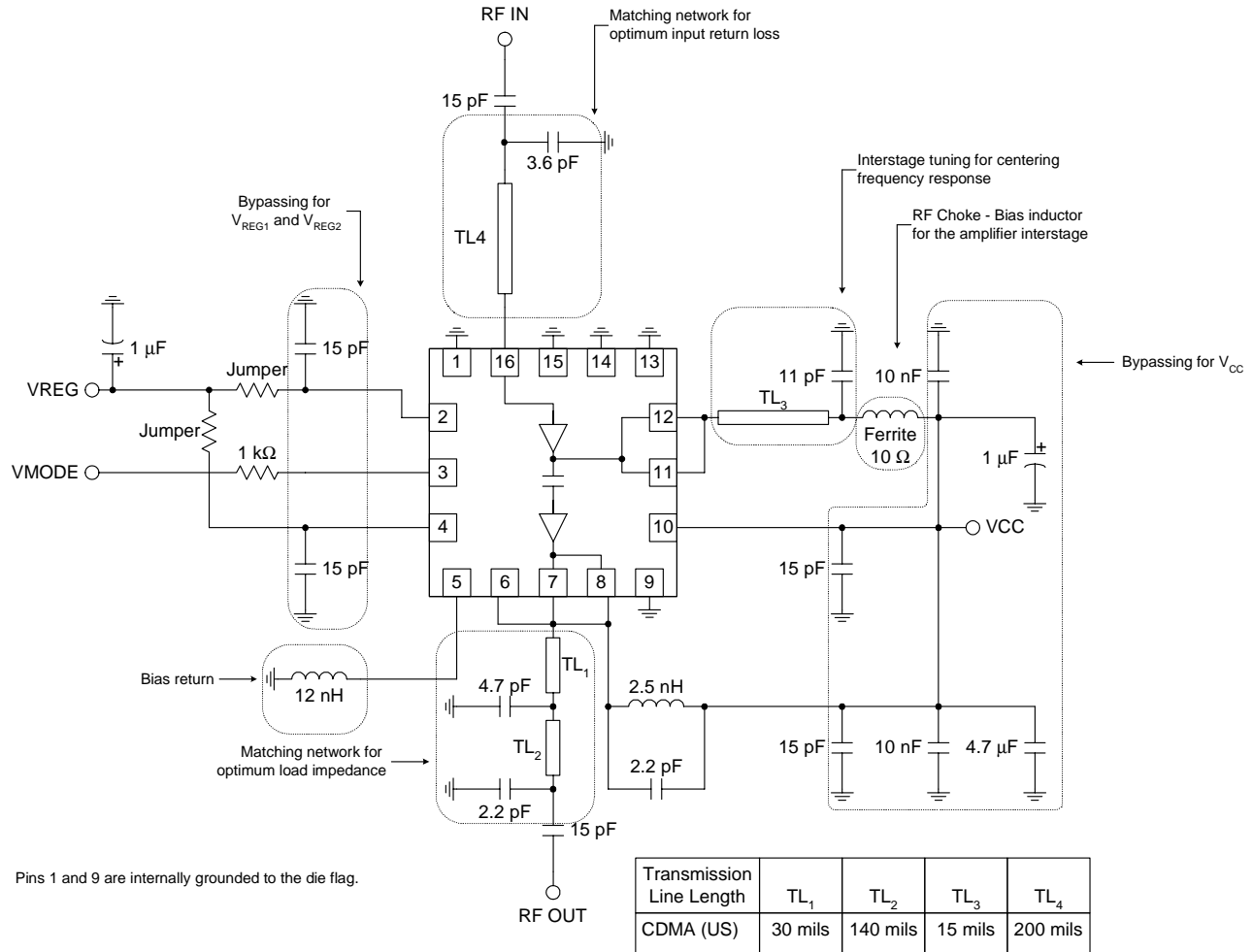

Evaluation Board Schematic US - CDMA

2

POWER AMPLIFIERS

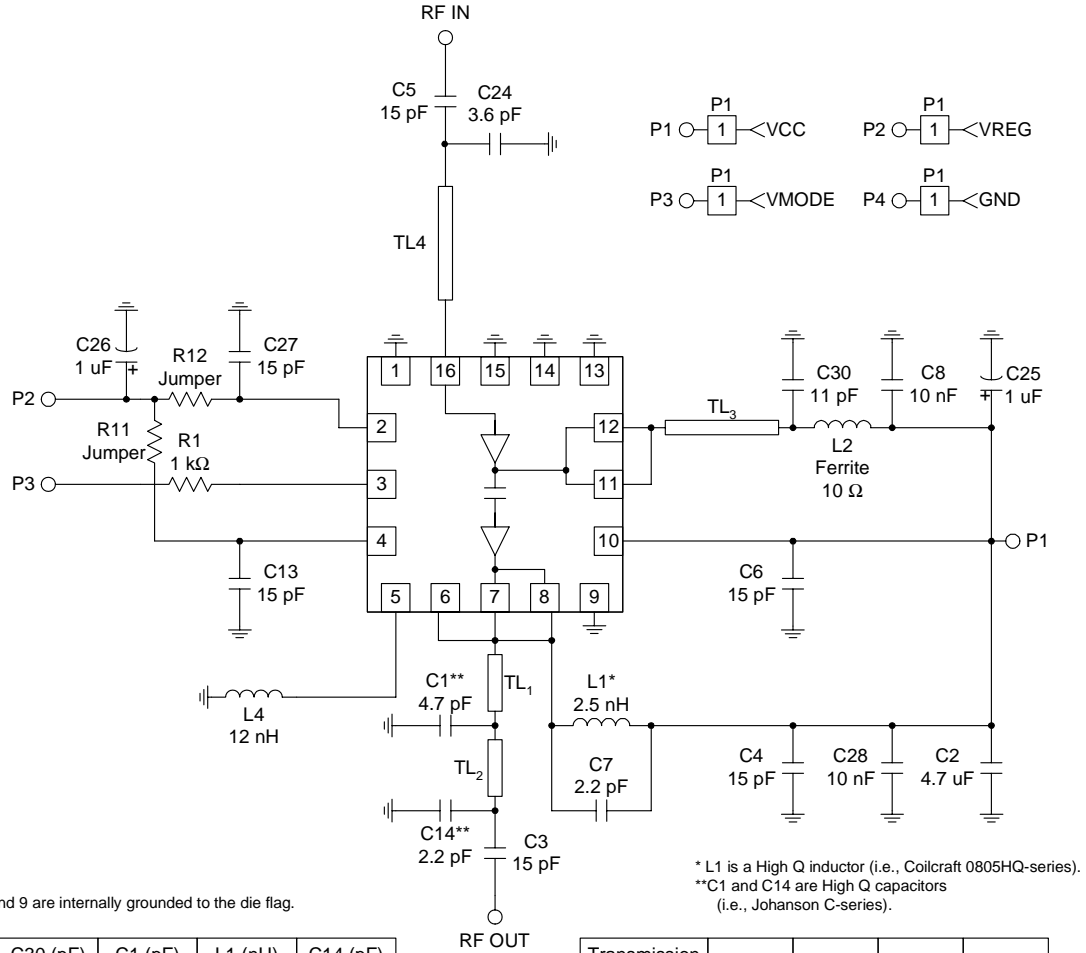

Board	C30 (pF)	C1 (pF)	L1 (nH)	C14 (pF)
CDMA (US)	11	4.7	2.5	2.2

Transmission Line Length	TL ₁	TL ₂	TL ₃	TL ₄
CDMA (US)	30 mils	140 mils	15 mils	200 mils

Evaluation Board Layout Board Size 2.0" x 2.0"

Board Thickness 0.028"; Board Material FR-4; Multi-Layer; Ground Plane at 0.014"

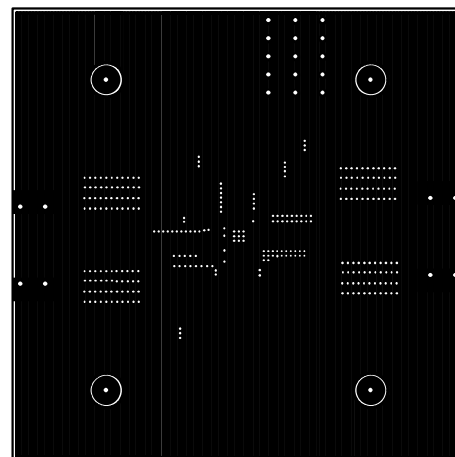
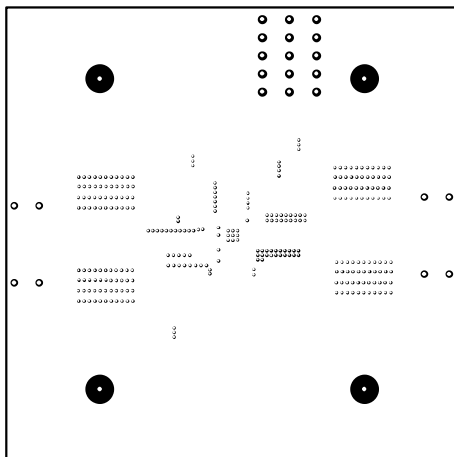
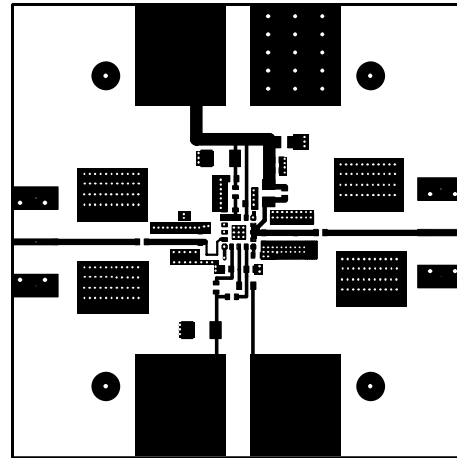
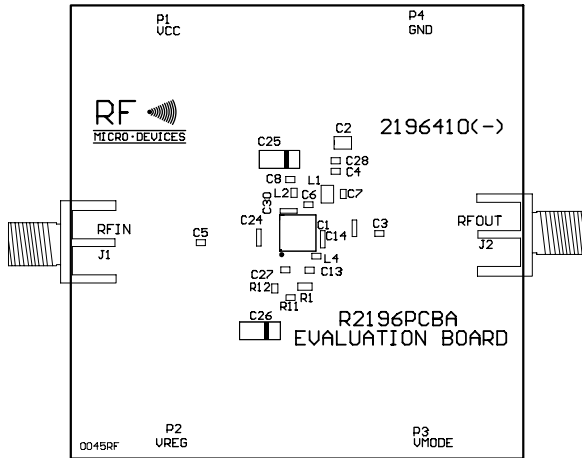

Copyright © Each Manufacturing Company.

All Datasheets cannot be modified without permission.

This datasheet has been download from :

www.AllDataSheet.com

100% Free DataSheet Search Site.

Free Download.

No Register.

Fast Search System.

www.AllDataSheet.com