



# PACKAGING SPECIFICATION GUIDE

# CONTENTS

**We know that space is often scarce on the brewery floor, so we have developed a packaging specification guide that is designed to help our customers understand exactly how much room our hops and innovative hop products will require in cool storage.**

## Contents

|  |    |
|--|----|
| 5KG FLOWERS (AUS) _____  | 3  |
| 10KG FLOWERS (AUS) _____   | 4  |
| 5KG T90 PELLETS (AUS) _____  | 5  |
| 20KG T90 PELLETS (AUS) _____   | 6  |
| VARIOUS SHIPPING CARTONS T90 PELLETS (AUS) _____                         | 7  |
| 20KG T45, T90 OR LUPOMAX® PELLETS (US) _____                             | 8  |
| 20KG T45, T90 OR LUPOMAX® PELLETS (EUR) _____                            | 9  |
| WARRIOR® CO <sub>2</sub> EXTRACT _____                                   | 10 |
| CTZ CO <sub>2</sub> EXTRACT _____  | 11 |
| FLEX®CO <sub>2</sub> EXTRACT _____                                       | 12 |
| TETRAHOP GOLD®, HEXAHOP GOLD®, OR REDIHOP® CO <sub>2</sub> EXTRACT _____ | 13 |
| KETTLE RED!® _____   | 14 |
| LIPOHOP K™ANTIFOAM _____   | 15 |
| HOPAID®ANTIFOAM _____  | 16 |
| INCOGNITO® _____   | 17 |
| PURE HOP AROMA® _____  | 18 |
| SPECTRUM _____   | 19 |
| QUICK REFERENCE _____  | 21 |

# 5kg FLOWERS (AUS)

## CASE

|                   |                |
|-------------------|----------------|
| Name              | 5kg CF5 Carton |
| Length (cm)       | 28             |
| Width (cm)        | 37             |
| Height (cm)       | 33             |
| Gross weight (kg) | 6              |

## PALLET

|                   |                     |
|-------------------|---------------------|
| Name              | PSO1ex Green Pallet |
| Length (cm)       | 111                 |
| Width (cm)        | 111                 |
| Height (cm)       | 13                  |
| Gross weight (kg) | 20                  |

## PALLET CONFIGURATION

|   |                 |
|---|-----------------|
| Case                                      | 5kg CF5 Carton  |
| Net weight (kg)                           | 180             |
| Gross weight (kg)                         | 216             |
| Gross weight incl. pallet (kg)            | 236             |
| Number of units                           | 36              |
| Number of layers                          | 3               |
| Number per layer                          | 12              |
| Packed pallet cube (m <sup>3</sup> )      | 1.37            |
| Packed pallet dimension incl. pallet (cm) | 111 x 111 x 112 |

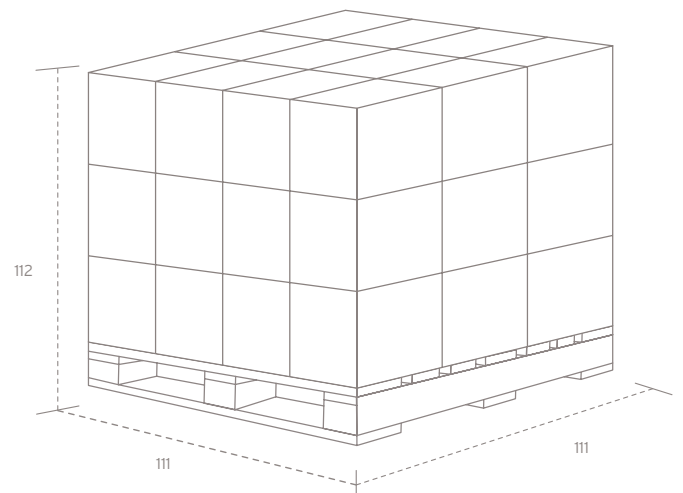
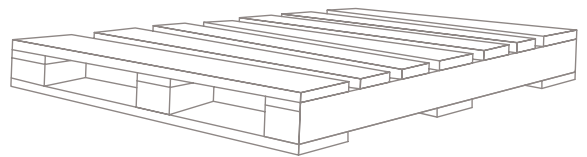

Drawings are not to scale

# 10kg FLOWERS (AUS)

## CASE

|                   |                  |
|-------------------|------------------|
| Name              | 10kg CF10 Carton |
| Length (cm)       | 55               |
| Width (cm)        | 37               |
| Height (cm)       | 33               |
| Gross weight (kg) | 12               |

## PALLET

|                   |                     |
|-------------------|---------------------|
| Name              | PS01ex Green Pallet |
| Length (cm)       | 111                 |
| Width (cm)        | 111                 |
| Height (cm)       | 13                  |
| Gross weight (kg) | 20                  |

## PALLET CONFIGURATION

|   |                  |
|---|------------------|
| Case                                      | 10kg CF10 Carton |
| Net weight (kg)                           | 180              |
| Gross weight (kg)                         | 216              |
| Gross weight incl. pallet (kg)            | 236              |
| Number of units                           | 18               |
| Number of layers                          | 3                |
| Number per layer                          | 6                |
| Packed pallet cube (m <sup>3</sup> )      | 1.37             |
| Packed pallet dimension incl. pallet (cm) | 111 x 111 x 112  |

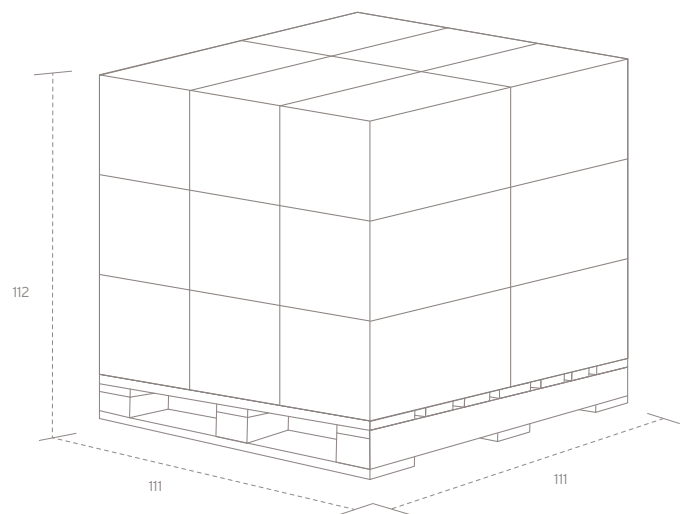
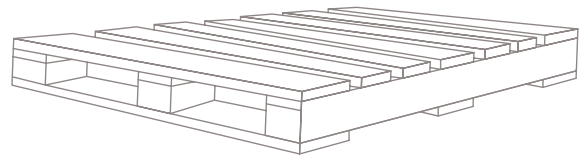

Drawings are not to scale

# 5kg T90 PELLETS (AUS)

## CASE

|                   |              |
|-------------------|--------------|
| Name              | 1x5kg Carton |
| Length (cm)       | 50           |
| Width (cm)        | 31           |
| Height (cm)       | 9            |
| Gross weight (kg) | 6            |

## PALLET

|                   |                 |
|-------------------|-----------------|
| Name              | P20 Blue Pallet |
| Length (cm)       | 112             |
| Width (cm)        | 112             |
| Height (cm)       | 12              |
| Gross weight (kg) | 23              |

## PALLET CONFIGURATION

|                                      |                 |
|--------------------------------------|-----------------|
| Case                                 | 1x5kg Carton    |
| Net weight (kg)                      | 480             |
| Gross weight (kg)                    | 528             |
| Gross weight incl. pallet (kg)       | 551             |
| Number of units                      | 96              |
| Number of layers                     | 12              |
| Number per layer                     | 8               |
| Packed pallet cube (m <sup>3</sup> ) | 1.50            |
| Packed pallet dimension incl. (cm)   | 112 x 112 x 124 |

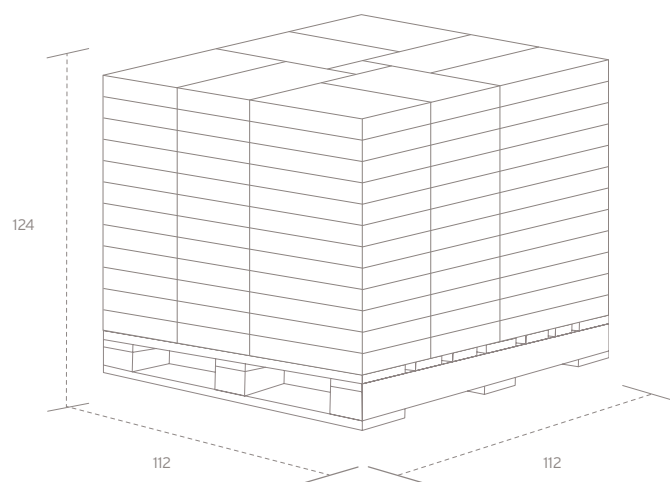
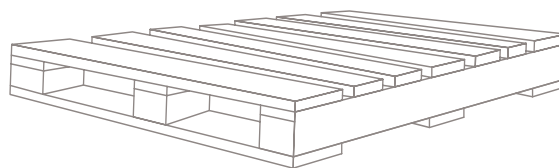

Drawings are not to scale

# 20KG T90 PELLETS (AUS)

## CASE

|                   |              |
|-------------------|--------------|
| Name              | 4x5kg Carton |
| Length (cm)       | 50           |
| Width (cm)        | 31           |
| Height (cm)       | 35           |
| Gross weight (kg) | 22           |



## PALLET

|                   |                 |
|-------------------|-----------------|
| Name              | P20 Blue Pallet |
| Length (cm)       | 112             |
| Width (cm)        | 112             |
| Height (cm)       | 12              |
| Gross weight (kg) | 23              |

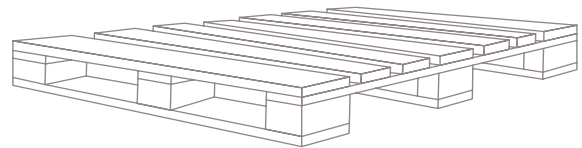

## PALLET CONFIGURATION

|   |                 |
|---|-----------------|
| Case                                      | 4x5kg Carton    |
| Net weight (kg)                           | 480             |
| Gross weight (kg)                         | 535             |
| Gross weight incl. pallet (kg)            | 558             |
| Number of units                           | 24              |
| Number of layers                          | 3               |
| Number per layer                          | 8               |
| Packed pallet cube (m <sup>3</sup> )      | 1.48            |
| Packed pallet dimension incl. pallet (cm) | 112 x 112 x 118 |

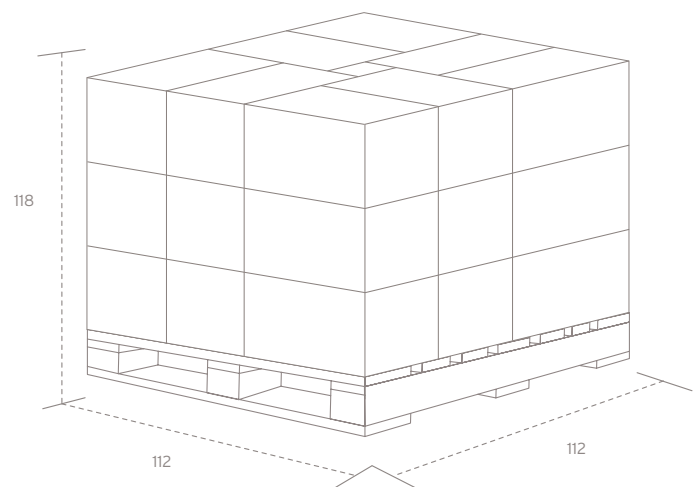

Drawings are not to scale

# SHIPPING CARTONS

## T90 PELLETS

(AUS)

### CASE

|                   |              |
|-------------------|--------------|
| Name              | 2x5kg Carton |
| Length (cm)       | 51           |
| Width (cm)        | 32           |
| Height (cm)       | 20           |
| Gross weight (kg) | 1            |

### CASE

|                   |              |
|-------------------|--------------|
| Name              | 3x5kg Carton |
| Length (cm)       | 51           |
| Width (cm)        | 32           |
| Height (cm)       | 29           |
| Gross weight (kg) | 1            |

### CASE

|                   |              |
|-------------------|--------------|
| Case              | 4x5kg Carton |
| Length (cm)       | 51           |
| Width (cm)        | 32           |
| Height (cm))      | 38           |
| Gross weight (kg) | 1            |



# 20KG T90 OR LUPOMAX® PELLETS (US)

## CASE

|                   |  |
|-------------------|--|
| Name              | 20kg US CS20 Carton<br>(4 x 5kg foils) |
| Length (cm)       | 61                                     |
| Width (cm)        | 41                                     |
| Height (cm)       | 21                                     |
| Gross weight (kg) | 22                                     |



## PALLET

|                   |                                 |
|-------------------|---------------------------------|
| Name              | P40R Red Double Entry<br>Pallet |
| Length (cm)       | 123                             |
| Width (cm)        | 103                             |
| Height (cm)       | 13                              |
| Gross weight (kg) | 20                              |

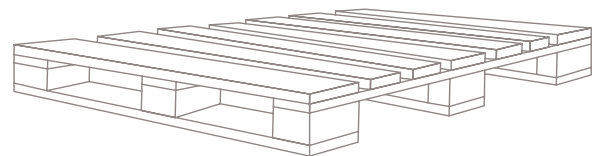

## PALLET CONFIGURATION

|  |                     |
|--|---------------------|
| Case   | 20kg US CS20 Carton |
| Net weight (kg)                              | 400                 |
| Gross weight (kg)                            | 440                 |
| Gross weight incl. pallet (kg)               | 460                 |
| Number of units                              | 20                  |
| Number of layers                             | 4                   |
| Number per layer                             | 5                   |
| Packed pallet cube (m <sup>3</sup> )         | 1.48                |
| Packed pallet dimension<br>incl. pallet (cm) | 123 x 103 x 118     |

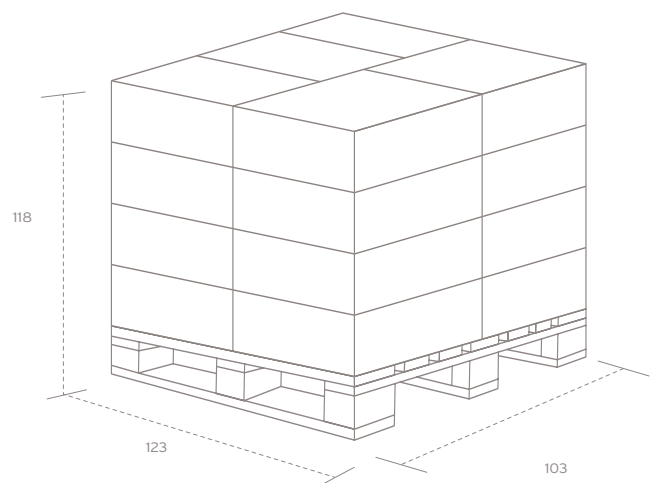

Drawings are not to scale

# 20KG

# T90 OR LUPOMAX<sup>®</sup> PELLETS

## (EUR)

### CASE

|                   |                       |
|-------------------|-----------------------|
| Name              | 5kg German CV5 Carton |
| Length (cm)       | 35                    |
| Width (cm)        | 32                    |
| Height (cm)       | 13                    |
| Gross weight (kg) | 6                     |



### PALLET

|                   |                     |
|-------------------|---------------------|
| Name              | PSO1ex Green Pallet |
| Length (cm)       | 120                 |
| Width (cm)        | 100                 |
| Height (cm)       | 11                  |
| Gross weight (kg) | 20                  |

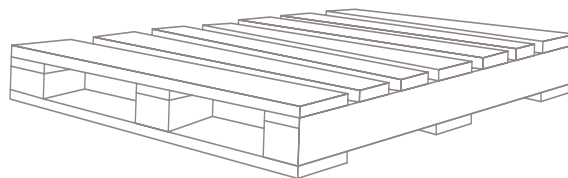

### PALLET CONFIGURATION

|   |                       |
|---|-----------------------|
| Case                                      | 5kg German CV5 Carton |
| Net weight (kg)                           | 315                   |
| Gross weight (kg)                         | 378                   |
| Gross weight incl. pallet (kg)            | 398                   |
| Number of units                           | 63                    |
| Number of layers                          | 7                     |
| Number per layer                          | 9                     |
| Packed pallet cube (m <sup>3</sup> )      | 1.29                  |
| Packed pallet dimension incl. pallet (cm) | 120 x 100 x 102       |

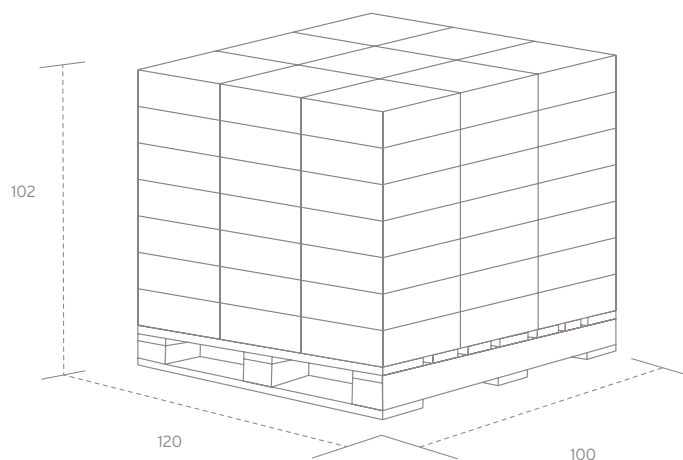

Drawings are not to scale

# WARRIOR<sup>®</sup> CO<sub>2</sub> EXTRACT

## TIN

|                   |                                  |
|-------------------|----------------------------------|
| Name              | 300g CO <sub>2</sub> Extract Tin |
| Height (cm)       | 14                               |
| Diameter (cm)     | 10                               |
| Gross weight (kg) | 0.3                              |

Please note: This may be bubble wrapped and repacked into cartons depending on quantity ordered.

## CASE

|                   |  |
|-------------------|--|
| Name              | 20 x 300g CO <sub>2</sub> Extract Tins |
| Length (cm)       | 41                                     |
| Width (cm)        | 31                                     |
| Height (cm)       | 30                                     |
| Gross weight (kg) | 8                                      |



# CTZ CO<sub>2</sub> EXTRACT

## TIN

|                   |                                 |
|-------------------|---------------------------------|
| Name              | 1kg CO <sub>2</sub> Extract Tin |
| Height (cm)       | 14                              |
| Diameter (cm)     | 10                              |
| Gross weight (kg) | 1                               |

Please note: This may be bubble wrapped and repacked into cartons depending on quantity ordered.

## CASE

|                   |                                       |
|-------------------|---------------------------------------|
| Name              | 20 x 1kg CO <sub>2</sub> Extract Tins |
| Length (cm)       | 41                                    |
| Width (cm)        | 31                                    |
| Height (cm)       | 30                                    |
| Gross weight (kg) | 22                                    |



# FLEX<sup>®</sup> CO<sub>2</sub> EXTRACT

## JUG

|                   |                                 |
|-------------------|---------------------------------|
| Name              | 2kg CO <sub>2</sub> Extract Jug |
| Length (cm)       | 16                              |
| Width (cm)        | 8                               |
| Height (cm)       | 23                              |
| Gross weight (kg) | 2                               |

**Please note:** This may be bubble wrapped and repacked into cartons depending on quantity ordered.

## CASE

|                   |                                      |
|-------------------|--------------------------------------|
| Name              | 8 x 2kg CO <sub>2</sub> Extract Jugs |
| Length (cm)       | 41                                   |
| Width (cm)        | 31                                   |
| Height (cm)       | 30                                   |
| Gross weight (kg) | 20                                   |



# TETRAHOP GOLD<sup>®</sup>, HEXAHOP GOLD<sup>®</sup>, REDIHOP<sup>®</sup> CO<sub>2</sub> EXTRACT

## DRUM

|                   |                                   |
|-------------------|-----------------------------------|
| Name              | 20kg CO <sub>2</sub> Extract Drum |
| Length (cm)       | 30                                |
| Width (cm)        | 30                                |
| Height (cm)       | 38                                |
| Gross weight (kg) | 22                                |



## PALLET

|                   |                              |
|-------------------|------------------------------|
| Name              | P40R Red Double Entry Pallet |
| Length (cm)       | 123                          |
| Width (cm)        | 103                          |
| Height (cm)       | 13                           |
| Gross weight (kg) | 20                           |

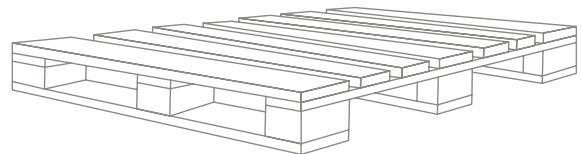

## PALLET CONFIGURATION

|   |                                   |
|---|-----------------------------------|
| Case                                      | 20kg CO <sub>2</sub> Extract Drum |
| Net weight (kg)                           | 480                               |
| Gross weight (kg)                         | 528                               |
| Gross weight incl. pallet (kg)            | 548                               |
| Number of units                           | 24                                |
| Number of layers                          | 2                                 |
| Number per layer                          | 12                                |
| Packed pallet cube (m <sup>3</sup> )      | 1.1                               |
| Packed pallet dimension incl. pallet (cm) | 123 x 103 x 91                    |

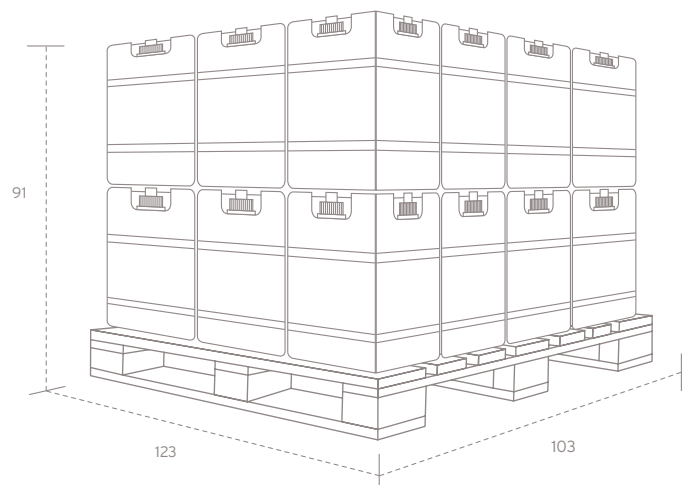

Drawings are not to scale

# KETTLE REDI®

## TUB

|                   |                      |
|-------------------|----------------------|
| Name              | 3kg Kettle Redi® Tub |
| Height (cm)       | 20                   |
| Diameter (cm)     | 20                   |
| Gross weight (kg) | 3                    |

**Please note:** This may be bubble wrapped and repacked into cartons depending on quantity ordered.

## CASE

|                   |                           |
|-------------------|---------------------------|
| Name              | 6 x 3kg Kettle Redi® Tubs |
| Length (cm)       | 60                        |
| Width (cm)        | 41                        |
| Height (cm)       | 21                        |
| Gross weight (kg) | 19                        |



# LIPOHOP K™ ANTIFOAM

## TUB

|                   |                  |
|-------------------|------------------|
| Name              | 1kg Antifoam Tub |
| Height (cm)       | 14               |
| Diameter (cm)     | 15               |
| Gross weight (kg) | 1                |

**Please note:** This may be bubble wrapped and repacked into cartons depending on quantity ordered.

## CASE

|                   |                        |
|-------------------|------------------------|
| Name              | 12 x 1kg Antifoam Tubs |
| Length (cm)       | 44                     |
| Width (cm)        | 33                     |
| Height (cm)       | 32                     |
| Gross weight (kg) | 13                     |



# HOPAID® ANTIFOAM

## CASK

|                   |                      |
|-------------------|----------------------|
| Name              | 2.25kg Antifoam Cask |
| Length (cm)       | 15                   |
| Width (cm)        | 10                   |
| Height (cm)       | 20                   |
| Gross weight (kg) | 2.25                 |

Please note: This may be bubble wrapped and repacked into cartons depending on quantity ordered.

## CASE

|                   |                           |
|-------------------|---------------------------|
| Name              | 4 x 2.25kg Antifoam Casks |
| Length (cm)       | 30                        |
| Width (cm)        | 22                        |
| Height (cm)       | 20                        |
| Gross weight (kg) | 10                        |



# INCOGNITO®

## JUG

| Name              | 1kg INCOGNITO® Jug | 2kg INCOGNITO® Jug |
|-------------------|--------------------|--------------------|
| Length (cm)       | 9                  | 16                 |
| Width (cm)        | 9                  | 8                  |
| Height (cm)       | 24                 | 23                 |
| Gross weight (kg) | 1                  | 2                  |



**Please note:** This may be bubble wrapped and repacked into cartons depending on quantity ordered.

## CASE

| Name              | 16 x 1kg INCOGNITO® Jugs | 8 x 2kg INCOGNITO® Jugs |
|-------------------|--------------------------|-------------------------|
| Length (cm)       | 39                       | 39                      |
| Width (cm)        | 35                       | 35                      |
| Height (cm)       | 25                       | 25                      |
| Gross weight (kg) | 18                       | 18                      |



# PURE HOP AROMA®

## CANISTER

|                   |                   |
|-------------------|-------------------|
| Name              | 1kg PHA® Canister |
| Height (cm)       | 28                |
| Diameter (cm)     | 90                |
| Gross weight (kg) | 1                 |

Please note: This may be bubble wrapped and repacked into cartons depending on quantity ordered.

## CASE

|                   |                         |
|-------------------|-------------------------|
| Name              | 12 x 1kg PHA® Canisters |
| Length (cm)       | 44                      |
| Width (cm)        | 33                      |
| Height (cm)       | 32                      |
| Gross weight (kg) | 14                      |

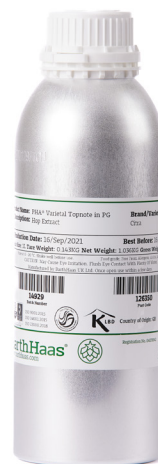

# SPECTRUM

## TUB

|                   |                  |
|-------------------|------------------|
| Name              | 1kg SPECTRUM Tub |
| Height (cm)       | 16               |
| Diameter (cm)     | 10               |
| Gross weight (kg) | 1                |

**Please note:** This may be bubble wrapped and repacked into cartons depending on quantity ordered.

## CASE

|                   |                       |
|-------------------|-----------------------|
| Name              | 8 x 1kg SPECTRUM Tubs |
| Length (cm)       | 24                    |
| Width (cm)        | 46                    |
| Height (cm)       | 18                    |
| Gross weight (kg) | 10                    |



# HOPHAZE®

## TUB

|                   |                  |
|-------------------|------------------|
| Name              | 1kg HopHaze® Jug |
| Height (cm)       | 23               |
| Diameter (cm)     | 9                |
| Gross weight (kg) | 1                |

**Please note:** This may be bubble wrapped and repacked into cartons depending on quantity ordered.

## CASE

|                   |                        |
|-------------------|------------------------|
| Name              | 16 x 1kg HopHaze® Jugs |
| Length (cm)       | 39                     |
| Width (cm)        | 40                     |
| Height (cm)       | 28                     |
| Gross weight (kg) | 20                     |



# QUICK REFERENCE

## CARTONS

| CASE          | DIMENSIONS                  | CAPACITY          |
|---------------|-----------------------------|-------------------|
| 1x5kg carton  | 50cm(l) x 31cm(w) x 9cm(h)  | 1 x 5kg foils     |
| 4x5kg carton  | 50cm(l) x 31cm(w) x 35cm(h) | 4 x 5kg foils     |
| 2x5kg shipper | 53cm(l) x 34cm(w) x 20cm(h) | 2 x 1x5kg cartons |
| 3x5kg shipper | 53cm(l) x 34cm(w) x 29cm(h) | 3 x 1x5kg cartons |
| 4x5kg shipper | 55cm(l) x 34cm(w) x 38cm(h) | 4 x 1x5kg cartons |

## PALLETS

| PALLET                       | DIMENSIONS                    | CAPACITY                                    |
|------------------------------|-------------------------------|---|
| P20 Blue Pallet              | 120cm(l) x 120cm(w) x 12cm(h) | 96 x 1x5, 24 x 4x5 cartons                  |
| PS01 Green Pallet            | 111cm(l) x 111cm(w) x 13cm(h) | 36 x CF5, 18x CF10, 63 x German CV5 cartons |
| P40R Red Double Entry Pallet | 123cm(l) x 103cm(w) x 13cm(h) | 20 x US CS20 cartons                        |

## INNOVATIVE HOP PRODUCTS CASE CONFIGURATIONS

### FLEX<sup>®</sup>

| QUANTITY    | DIMENSIONS                  | WEIGHT |
|-------------|-----------------------------|--------|
| 8 x 2kg jug | 41cm(l) x 31cm(w) x 30cm(h) | 20kg   |

### KETTLE REDI<sup>®</sup>

| QUANTITY                         | DIMENSIONS                  | WEIGHT |
|----------------------------------|-----------------------------|--------|
| 3kg Kettle Redi <sup>®</sup> Tub | 60cm(l) x 41cm(w) x 21cm(h) | 19kg   |

### HOPAID<sup>®</sup>

| QUANTITY         | DIMENSIONS                  | WEIGHT |
|------------------|-----------------------------|--------|
| 4 x 2.25kg casks | 30cm(l) x 22cm(w) x 20cm(h) | 10kg   |

### INCOGNITO<sup>®</sup>

| QUANTITY     | DIMENSIONS                  | WEIGHT |
|--------------|-----------------------------|--------|
| 16 x 1kg jug | 39cm(l) x 35cm(w) x 25cm(h) | 18kg   |
| 8 x 2kg jugs | 39cm(l) x 35cm(w) 25cm(h)   | 18kg   |

### PURE HOP AROMA<sup>®</sup>

| QUANTITY           | DIMENSIONS                  | WEIGHT |
|--------------------|-----------------------------|--------|
| 12 x 1kg canisters | 44cm(l) x 33cm(w) x 32cm(h) | 14kg   |

### SPECTRUM

| QUANTITY     | DIMENSIONS                  | WEIGHT |
|--------------|-----------------------------|--------|
| 8 x 1kg tubs | 24cm(l) x 46cm(w) x 18cm(h) | 10kg   |

### HOPHAZE<sup>®</sup>

| QUANTITY                           | DIMENSIONS                  | WEIGHT |
|------------------------------------|-----------------------------|--------|
| 16 x 1kg HopHaze <sup>®</sup> Jugs | 39cm(l) x 33cm(w) x 28cm(h) | 20kg   |

