

BSW

ORBAN OPTIMOD 5750-HD GRAB MORE EARS WITH BSW

SEE P. 7 FOR MORE!



5750-HD

BSW AIRCANS HEADPHONE 5-PACK

5 FOR \$149
SEE P. 184!



FUTURE-READY RADIO



JUST ADD AUDIO

GV2 transmitters can integrate all HD Radio™ components inside the transmitter, providing support for HD Radio™ with Xperi Gen4 Importer, Exporter, and Engine implementations for HD Radio™ encoding, station logo and artist experience. Omnia® for Nautel covers all FM and HD Radio™ audio processing and provides Livewire® AoIP inputs for all audio streams. No additional hardware is required*.

*Requires purchase of Nautel's optional Software-Based Air Chain and appropriate Xperi licensing.

An Industry 1st



AUDIO IN



RF OUT



Processed Audio
FM-HD Locked
HD Radio RF out

HAPPY NEW GEAR!

Welcome to BSW's brand-spanking new 2025 Sourcebook! We are psyched to show you our latest collection of great gear from the world's best manufacturers.

Before we look ahead to the new year, I've got to mention a couple cool things BSW started in 2024. We added more purchasing options for our B2B partners and created the BSW Advantage Club, offering secret sales, discounts, and flexible purchasing and shipping options.

This season, we are thrilled to introduce many new products with cutting-edge technology that pushes more envelopes than the Postmaster General does in the two weeks before Christmas. Our team is dedicated to keeping you at the forefront of our industry with this new-fangled gear, but we haven't forgotten the time-tested favorites. Some products in these pages have been featured in BSW sourcebooks going back 50 years!

You Are at the Heart of Everything We Do

We not only take pride in delivering top-tier gear, but also in providing top-shelf service. If you have questions or need assistance, our team is always here to help.

Our Deepest Thanks for Your Loyalty and Trust

Your continued support drives us to constantly improve and innovate. We look forward to serving you and hope you enjoy digging into this sourcebook as much as we enjoyed creating it for you.

Bryan Seeley, Director of Sales and Marketing
BryanS@bswusa.com

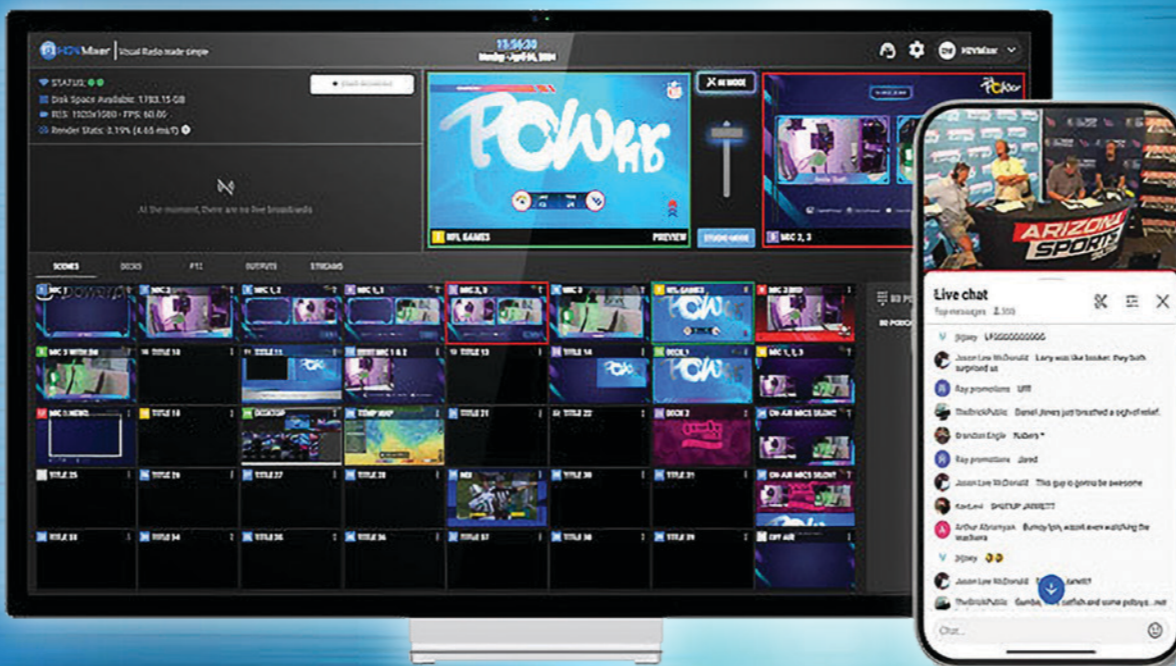

HDVMIXER 2.0 VIDEO FOR RADIO

SEE P. 43, 46



BROADCAST PROCESSING

SEE P. 6-21



MICS, HEADSETS & HEADPHONES

SEE P. 56-60, 157-160, 163-184, 164-169, 179-180, 183-184

BOOSTING BROADCASTERS SINCE 1973



TABLE OF CONTENTS

- Video for Radio* 42, 43, 46
- Codecs* 72-85, 110, 132
- Consoles* 26-32, 34-41
- Transmitters* 95-101
- Headphones* 183-184
- Digital Recording* 134-140
- Live Sound* 144-147, 154
- Podcasting* 187-191
- Video* 46-49
- Cables* 200-201

BSW

ADVANTAGE CLUB

GET THAT EXTRA EDGE

EXCLUSIVE DISCOUNTS

Preferred discounted pricing on all eligible online products. With a couple clicks of your mouse or taps on your phone, you could stretch your budget like sweet, sweet taffy.

GET THE VIP TREATMENT

Complete online access to current and past purchases. Set up specific buyers and permissions on your account. Plus Advantage Club VIPs will each have a dedicated sales rep at their beck and call. It's like having a personal assistant you don't have to pay!

MORE WAYS TO SAVE & PAY

Better shipping rates, period. And more ways to pay for your shiny new BSW gear: Old-school purchase orders for the rugged traditionalist, set-it-and-forget-it ACH for the ball-juggling multitasker, and Apple/Google Pay for the brave new futurist.

BECOME A MEMBER

Apply on BSWUSA.com under Business Accounts, Email sales@bswusa.com or Call 1-800-426-8434.



More online!
Scan to sign up.

THE BEST OF BSW

BSW & Nautel

From 150W to 50kW, BSW has partnered with Nautel to bring you the best deals! Call BSW to get your transmitter off (and then on) the ground! See pages 96-97 for more



VX300

Need a New Console? Take Your Pick.

AXIA, Audioarts, Wheatstone, Arrakis, Angry Audio. BSW has it all. See pages 6-15 for more



H-15



DML-12-LYRIC



QUASAR



RAVE-PKG



IP-16



ARCADIAX4

Need Clear-Com? You Need BSW!

BSW is a national distributor of Clear-Com, so we can handle all your intercom needs quickly, efficiently, and at a great price. See pages 192-197 for more



LQ-2W2



The New Generation of OPTIMOD Audio Processors



FM & HD Radio Audio Processor OPTIMOD 5950

NEW Super Hi-Fi option for 5950!

MX Peak Limiter - Subharmonic Synthesizer - Multipath Mitigator
HTML5 Web Control - RDS Encoder - Digital MPX
µMPX Interface - Watermarking Encoders



BSW
 www.bswusa.com
 Call BSW for all your ORBAN needs.
 1-800-426-8434 • www.BSWUSA.com



Innovative Digital Processing by Orban



More online!
Scan for full specs.



NEW

5950

Pristine Processing for FM and Digital Media

- Orban's OPTIMOD 5950 has Orban's proprietary MX Peak Limiter (louder & cleaner).
- Makes FM analog broadcasts more competitive with the cleanliness, punch and open high frequencies of digital media
 - Digital output for streaming, netcasting, digital satellite or cable radio
 - Stereo enhancement, equalization, AGC, multiband compression
 - Low-IM peak limiting, stereo encoding, composite limiting.
 - More than 20 excellent sounding, format specific factory presets
 - Easily customize presets with one-knob LESS-MORE control

- Improved peak limiter technology decreases distortion
- Full-featured RBS/RBDS generator
- AES-67 IP audio Interface

5950 FM and DAB+/HD radio processor List—\$9,995.00 *

Add-on:
FM-WATERMARK List—\$595.00 **\$550.00**

*Prices too low to advertise. Call BSW for the lowest price 1-800-426-8434.



More online!
Scan for full specs.



NEW

5750

Feature-Packed FM and Digital Radio Audio Processors

Orban's OPTIMOD 5750 is a high-quality audio processor for FM and digital radio offering a compact 1RU design, a high-resolution touch display, and control via any HTML5 web browser. It provides processing for FM analog as well as DAB+, HD Radio and streaming. The FM and HD settings can be coupled to make the blend between analog and HD1 as smooth as possible in HD Radio. The FM and digital processing can also be adjusted independently. This is valuable when the digital processing drives a channel that does not require blending, such as an Internet stream. The OPTIMOD 5750-HD adds HD2 processing for more broadcasting versatility.

- 5-band, low-latency 5-band, ultra-low-latency 5-band and 2-band processing structures
- Intelligent 2-band window-gated AGC controls levels subtly and unobtrusively
- True Peak limiter anticipates and controls peak levels following D/A conversion
- Onboard RDS/RBDS generator supports dynamic PS scrolling and IP access

5750 List—\$5,995.00 **\$5,545.00**
5750-HD List—\$8,595.00 **\$7,950.00**

Add-on:
 5750 FM-Watermark Dual Internal Watermarking Encoders:
 IPSOS or Nielsen encoding

FM-WATERMARK List—\$595.00 **\$550.00**
HD-WATERMARK List—\$735.00 **\$550.00**

Add-on:
 5750-HD FM-Watermark HD 3 Internal Watermarking Encoders:
 IPSOS or Nielsen encoding

FM-WATERMARK List—\$795.00 **\$735.00**
HD-WATERMARK List—\$795.00 **\$735.00**
HD2-WATERMARK List—\$795.00 **\$735.00**

Why settle for ordinary when you can have
Orban extraordinary?

800.426.8434

Jamie Singer, GearHead
 JamieS@bswusa.com





Atomic Option Slashes Your Power Bill



Boost Your Ratings - Increase TSL Sound Better, Louder and Cleaner Major Increase in Coverage

Digital Processing for Legendary Orban Sound



Energy-Saving AM Processor Pays for Itself

Orban's XPN-AM is designed to reduce your AM power consumption by up to 20%, making it the world's first processor that will actually pay for itself. It also offers loud, clean, crisp, and virtually distortion-free sound quality.

- Exclusive MX limiter increases average modulation
- 20% power savings when compared to other AM processors when running MDCL at 3 dB AMC
- Processing for multiple broadcast types

- Cuts through today's high RF noise environments
- Mono/stereo analog AM processing and HD Radio/netcast processing with built-in diversity delay and delay ramping.
- Versatile transmitter equalizer
- Variable bandwidth from 2.5 KHz to 9.5 KHz (NRSC)
- Complements the high frequency roll-off

XPN-AM-ND List-\$11,995.00*
XPN-AM-HD List-\$12,945.00

*Prices too low to advertise. Call BSW for the lowest price 1-800-426-8434.

MPX Peak Limiter Technology for Airy Highs and Ultra-Low Distortion!



More online!
Scan for full specs.

COMBINE WITH THE POWER OF NAUTEL AND
SAVE THOUSANDS ON YOUR ENERGY BILL!
[HTTPS://WWW.NAUTEL.COM/MDCL-SAVINGS/](https://www.nautel.com/mdcl-savings/)



Dedicated Sound Processing Card and Software

The Orban Optimod-PC 1101e professional Microsoft Windows audio processing card for PCIe bus systems offers dedicated, broadcast-quality digital signal processing on-board for audio processing, mixing, and routing.

The OPTIMOD-PCN 1600 server-based PC audio processing software is a flexible and scalable processing solution offering phase skew correction, stereo enhancement, intelligent automatic gain control (AGC), equalization, multiband gain control, peak-level control, and smart automatic loudness control.

- | | | | |
|-----------|-----------------------------------------------------|-----------------|-------------------|
| PC1101E | Stereo processing card for Windows | List-\$1,850.00 | \$1,711.00 |
| PCN1600 | Audio processing software for Windows | List-\$1,010.00 | \$934.00 |
| PCN1600NL | PCN1600 with integrated Nielsen/Kantar Watermarking | List-\$1,395.00 | \$1,290.00 |



More online!
Scan for full specs.

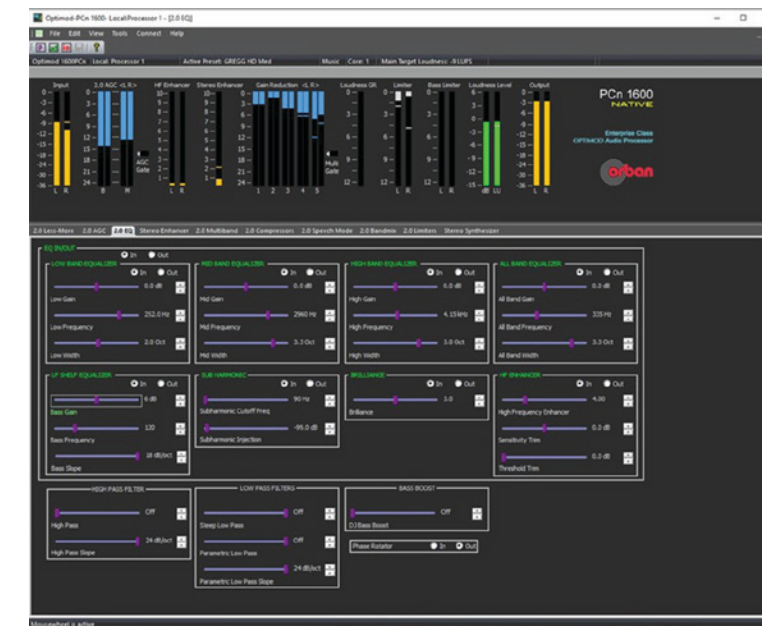

PCN1600

Boldly Go with XPN-Enterprise



More online!
Scan for full specs.



24 Channels of OPTIMOD 8700i Flagship Processing

OPTIMOD XPN-Enterprise offers a completely new approach to processing compared to the existing Orban hardware product range. It is an easy-to-use, Linux-based, customizable processing platform for multiple broadcast stations or streaming services with centralized control. Supports AES67, SMPTE2110/2027-7 – dual redundant fault tolerant networks, Dante and Livewire+ and allows you to set up a state-of-the-art AoIP audio processing system. By using appropriate XPN-E Node, other common methods of transport such as AES3 are supported as well and necessary outputs (FM Composite, DMPX, uMPX, and DAB+/HD Radio) for the distribution to the transmitter sites can be provided. XPN Enterprise solutions are all customized for specific user requirements. Call BSW for more information.

- Linux-based Dell Blade
- Fully modular processing for up to 16 FM plus HD/DAB+ outputs (using the FM MPX HD/DAB+ Nodes)
- Streaming Node brings total channel count to 24
- AoIP: AES67, SMPTE-2110/2027-7 (Dual Redundant Networks) and Livewire+

XPN-ENTERPRISE-SERVER List \$16,995.00 **\$15,720.00**



XPN-Enterprise

AES Node features dual redundant Gigabit Ethernet audio interfaces with 8 stereo AES inputs and outputs. It supports SMPTE ST 2022-7 1+1 redundancy, packet times: 125µs, 250µs, and 1ms, Samples/packet: 6, 12, and 48, Sample rates: 48kHz with ASRC available and 44.1kHz with ASRC available, receives up to a 64 channel stream, supports the L24 and L16 audio formats, SMPTE ST 2110-30, including all conformance levels: A, B, and and supports discovery and registration via both RAVENNA and Dante/SAP (only in AES67 mode).

AES-10-NODE 8 AES3 inputs and outputs, dual redundant AoIP, PoE and external worldwide power supply, 1/3RU List \$4,595.00 **\$4,250.00**

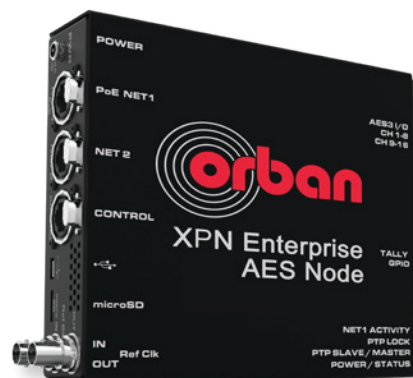

Score a Triple Play!



TRIO

Three Great Processors in One Compact Box

The Orban OPTIMOD Trio is the culmination of 50 years of Orban processing experience. Following OPTIMOD 5950 and OPTIMOD 5750, the Trio is the third in line of Orban's next generation of audio processors. The Trio can easily be field configured as an AM Audio Processor, FM Audio Processor or alternatively as an DAB+, HD Radio and streaming audio processor. Trio's flexibility coupled with its outstanding audio performance fulfills any broadcast requirement.

OPTIMOD Trio provides four FM processing structures. It can be also used as stand-alone stereo encoder with ultra-low latency and full overshoot limiting. With OPTIMOD Trio you can achieve excellent quality in AM shortwave, medium wave and long wave broadcast sound. For HD, OPTIMOD Trio delivers a spectrally consistent sound with good loudness control. The "True Peak" limiter anticipates and controls peak levels following D/A conversion, a feature now required by many broadcasters.

- High quality AM shortwave, medium wave and long wave broadcast sound
- Four FM processing structures: 5-band, low latency 5-band, ultra-low latency 5-band and 2-band
- Ethernet network interface for a range of AoIP connections

TRIO List \$4,995.00 **\$4,620.00**
Add-on:
TRIO-WATERMARK List \$395.00 **\$365.00**



More online!
Scan for full specs.

Add-ons for all 3 Processors!

FM-APTMPX	Transmission using APTmpX encoding interface	List \$795.00	\$735.00
HLS-PLUS-DECODER	Specialized IP stream decoding for HLS+ audio sources	List \$295.00	\$273.00
OM-BACKUP	Decodes IP streams in MP3 and OPUS Formats	List \$273.00	\$273.00
OM-REMOTE	Remote monitoring of processed audio via IP	List \$495.00	\$458.00
OM-STORAGE	Robust audio backup via internal storage	List \$395.00	\$365.00

Find what you need. Whenever you need it.

BSWUSA.COM





Lock in your listeners!

Radio isn't for the faint of heart; it's a high-stakes, winner-take-all game where second place is only a footnote. You need every edge you can get to hook and hold your audience.

That's why the winners choose Omnia®. Only Omnia gives you the world-class sound that grabs listeners by the ears and locks them in. It's the competitive edge that makes your station sound like a champion — and knocks out the competition.

FM, HD, DAB, or streaming, Omnia has you covered. Lock it in, and rip the knob off!



Omnia Forza FM

FM + HD/DAB processing software worthy of the Omnia crown.



Omnia.9

The ultimate toolbox for audio processing perfectionists.



Omnia.11

The proven winner. Nothing compares to The King.



Call BSW for your best price on Telos Alliance 1-800-426-8434

Electrifying Processing from Omnia



NEW 2.0



Versatile VOLT Audio Processor

The Omnia VOLT from the Telos Alliance offers incredible processing power for louder, cleaner and more dynamic sound in a compact, single rack unit. It features a wideband AGC, a five-band AGC, five time-aligned multiband limiters, stereo enhancement, and unrivaled factory presets. Omnia's exclusive Sensus® algorithm pre-conditions audio destined for data-reduced paths including HD, DAB, and streaming audio, improving sound quality and minimizing artifacts even with low bitrate encoding. VOLT gives you more sonic performance and processing power in one rack unit than others give you in three. Call or visit our website for more info.

VOLT	FM processor	List—\$3,895.00	\$3,506.00
VOLT-HD-PRO	HD/DAB processor	List—\$3,895.00	\$3,506.00
VOLT-AM	AM processor	List—\$3,895.00	\$3,506.00
MPXNODE-DECODER	Decoder	List—\$1,995.00	\$1,796.00
MPXNODE-ENCODER	Encoder	List—\$1,995.00	\$1,796.00



Loaded Stereo Generator

Sometimes it makes more sense to locate your main audio processor at the studio and place the stereo generator and limiter at the transmitter site. Omnia.9sg brings the same acclaimed clipper, limiter, and stereo generator technology in the Omnia.9 to a standalone box and delivers convenient full IP remote streaming. It's also available with an integrated RDS encoder.

OMNIA9SG	Stereo generator	List—\$4,995.00	\$4,496.00
OMNIA9SG-RDS	Stereo generator with RDS	List—\$5,795.00	\$5,216.00

Professional Omnia Audio Processing Software

OmniaSST is full-featured audio processing software that transforms Windows PCs into high-end audio processors. It supports the Omnia µMPX codec, which transports high-quality multiplexed FM signals over a small 320 kbps data pipe. High-quality multiplexed audio and RDS signals can be directly routed over IP from your processor into a decoder application for efficient MPX audio transport.

OMNIASST-UMPX	with µMPX codec	List—\$1,595.00	\$1,436.00
OMNIASST	Audio processing software	List—\$1,195.00	\$1,076.00

Cleans and repairs incoming audio by optimizing, removing hum, repairing clipped audio and improving compressed sound!



Powerful Audio Processing from Omnia



**BSW
CUSTOMER
FAVORITE**

Omnia.11 for Market Dominating Sound

The Omnia.11 offers ultra-high-quality FM processing to help you stand out from the competition. With the proven Omnia.11 Version 4 software update featuring the Frank Foti-designed Silvio Clipper (available only in G-Force), you'll broadcast an even cleaner, brighter, more open sound, but without having to worry about any loudness penalties. You also get a broad assortment of presets across multiple station formats to take full advantage of the new Silvio Clipper's extended capabilities.

OMNIA11	FM/HD processor	List \$16,295.00	\$14,666.00
OMNIA11-NONHD	FM-only processor	List \$13,295.00	\$11,966.00
OMNIA-GFORCE	G-Force Dynamics Update for Old Units	List \$1,200.00	\$1,080.00
OMNIA11-DECLIPPER	Declipper audio processing option	List \$550.00	\$495.00
OMNIA11-FMHD-DECLIPPER	FM/HD audio processor with declipper	List \$16,795.00	\$15,116.00
MPXNODE-DECODER	Decoder	List \$1,995.00	\$1,796.00
MPXNODE-ENCODER	Encoder	List \$1,995.00	\$1,796.00
OMNIA11-FM-DECLIPPER	Multi-Band FM (NON-HD) Audio Processor with Perfect Declipper	List \$13,795.00	\$12,416.00

FREE OMNIA.11 VERSION 4 SOFTWARE UPDATE WITH SILVIO CLIPPER FOR EVEN BRIGHTER, CLEANER, MORE OPEN SOUND!

Omnia.9: Powerful and Versatile

Omnia.9 boasts simultaneous separate processing cores for AM, FM, HD/DAB, and streaming audio (including streaming encoding), delivering superb audio punch, power and clarity in a 3-RU rack unit. Among its many features is exclusive "Undo" technology, a source declipping algorithm and program-adaptive multi-band expander that removes distortion from clipped, hyper-compressed source material.

- Multiband downward expanders reduce source noise reduction
- 3-stage wideband AGC and 2 to 7 bands of multiband processing
- Separate processing and encoding for streaming audio outputs
- Built-in analysis tools including loudness metering, digital oscilloscope, FFT spectrum analyzer, and RTA
- Available RDS encoding, uMPX encoding, and Kantar and Nielsen watermark encoding



See the video at bswusa.com/OMNIA9

OMNIA9-DUAL-FM	Dual Multi Band FM Audio Processor with dual path version (RDS, HD and Streaming)	List \$19,995.00	\$17,996.00
OMNIA9-DUALFM-STREAMING-OPTION	Upgrades single FM unit to dual FM with HD	List \$8,750.00	\$7,875.00
OMNIA9-FM	Multi Band FM Audio Processor	List \$13,295.00	\$11,966.00
OMNIA9-HD1-OPTION	HD-1 + Single Streaming Option for OMNIA9-FM	List \$2,650.00	\$2,385.00
OMNIA9-HD2-OPTION	Adds separate HD-2 processing for units already equipped with HD-1 processing	List \$2,650.00	\$2,385.00
OMNIA9-HD3	Omnia 9 HD3 upgrade	List \$2,650.00	\$2,385.00
OMNIA9-RDS-OPTION	RDS option for OMNIA9-FM	List \$850.00	\$765.00
OMNIA9SG	Stereo Generator	List \$4,995.00	\$4,496.00
OMNIA9SG-AUX-RDS	Stereo Generator with Auxiliary Input Processing and RDS	List \$6,695.00	\$6,026.00
OMNIA9SG-RDS	Stereo Generator with RDS	List \$5,795.00	\$5,216.00
OMNIA9-UMPX-2LIC	uMPX 2 Additional Output Stream License	List \$750.00	\$675.00
OMNIA9-UMPX-LIC	Adds Omnia uMPX encoding	List \$900.00	\$810.00

Smooth Processing with Omnia Forza



NEW

Powerful Audio Processing Software

Omnia Forza brings legendary Omnia processing to the software domain, making it ideal for today's server- and cloud-based scalable facilities, and features native Livewire+ AES67 AoIP I/O. Forza FM is optimized for the demands of FM/HD processing and includes Frank Foti's proven Silvio clipper from Omnia.11, plus two uMPX outputs. Forza HDS is specifically designed for L/R audio applications such as HD-2/3/4, DAB, and streaming. It includes an integrated target-driven ITU-R BS.1770 loudness controller for set-and-forget conformance to streaming loudness requirements.

- Available to purchase outright or by subscription
- Wideband AGC, 5 bands of multiband AGC, 5 bands of multiband limiting, plus soft and hard bass clippers
- Carefully crafted Omnia presets ensure great-sounding audio on all types of formats and programs
- Sensus conditioning for low bitrate streams and HD Radio
- Silvio FM clipper and stereo generator with integrated RDS (Forza FM)
- Built-in diversity delay time-aligns FM signal to HD1 output (Forza FM)
- Loudness controller for streaming loudness requirements (Forza HDS)

OMNIA-FORZA-FM	Forza FM container license	List \$3,495.00	\$3,146.00
OMNIA-FORZA-FM-1YR	Forza FM one-year license	List \$1,395.00	\$1,256.00
OMNIA-FORZA-HDS-1YR	Forza HDS one-year license	List \$695.00	\$626.00
OMNIA-FORZA-HDS	Forza HDS container license	List \$1,295.00	\$1,166.00

Accessories / Options:

OMNIA-FORZA-KANTAR	Kantar watermarking for container license	List \$295.00	\$266.00
OMNIA-FORZA-KANTAR-1YR	Kantar watermarking for one-year license	List \$125.00	\$113.00
OMNIA-FORZA-NIELSEN	Nielsen watermarking for container license	List \$995.00	\$896.00
OMNIA-FORZA-NIELSEN-1YR	Nielsen watermarking for one-year license	List \$395.00	\$356.00
OMNIA-FORZA-FM-UMPX	Omnia uMPX codec for Forza FM - two extra streams	List \$895.00	\$806.00
OMNIA-FORZA-FM-UMPX-4	Omnia uMPX codec for Forza FM - four extra streams	List \$1,295.00	\$1,166.00
OMNIA-FORZA-FM-UMPX-4-1YR	Omnia uMPX with four extra streams one-year license	List \$525.00	\$473.00



CHECK OUT THOUSANDS MORE PRODUCTS AT BSWUSA.COM



Grab Listeners with Inovonics and BSW

Advanced, Reliable Remote Signal Monitor

Inovonics' SOFIA 563 DAB+ SiteStreamer+ gives you advanced features for critical monitoring situations. A Web-enabled DAB/DAB+ receiver for remote signal monitoring the SOFIA 563 is installed at a broadcast transmitter site or any remote location with good reception and Internet. Streamed audio is accessible from any Web enabled device. It provides Analog LR, AES-Digital and Dante AES67 AoIP-streaming audio outputs.

- Remotely monitors fulltime off-air DAB/DAB+ signals
- Displays graphics and related text data on Web interface
- Adjustable off-air output levels for LR analog, AES3-digital and Dante/AES67 AoIP
- Alarms and notifications sent via email or SMS messaging



563 List \$2,500.00 **\$2,250.00**



CALL BSW FOR ALL YOUR INOVONICS NEEDS! 800.426.8434



568

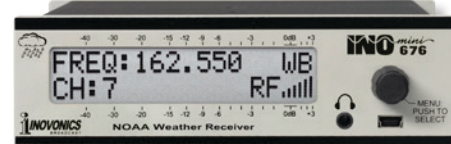

676



673



679



661

Comprehensive Confidence Monitoring and More

Inovonics' INOmini DSP-based radio monitor/receivers offer plenty of advanced features in a small footprint. The 674 works as a confidence monitor (with alarms) for AM broadcasts. The 673 monitors standard FM broadcasts and can also work as a rebroadcast receiver in FM translator service. The 676 receives NOAA weather information and alerts. The 679 monitors both analog FM and digital HD1-HD8 radio channels and delivers a high-quality audio feed for rebroadcast or program distribution throughout the broadcast facility. It also displays FM RBDS and HD Radio PAD data. The 661 provides off-air reception of all standard DAB and DAB+ broadcasts.

- Sensitive, small footprint DSP-based receivers
- Flashing-red front-panel alarms and rear-panel tallies indicate Audio Loss and other issues

- Balanced analog and AES-digital program line outputs are available simultaneously with independent level adjustment
- Front-panel mini-USB port allows quick uploading of firmware updates when issued

565	SOFIA FM SiteStreamer+	List—\$2,400.00	\$2,160.00
567	SOFIA AM SiteStreamer+	List—\$2,300.00	\$2,070.00
568	SOFIA HD Radio SiteStreamer+	List—\$2,500.00	\$2,250.00
674	INOmini AM Broadcast Receiver	List—\$1,050.00	\$945.00
673	INOmini FM RDS Receiver	List—\$1,000.00	\$972.00
676	INOmini NOAA Weather Receiver	List—\$990.00	\$891.00
679	INOmini FM HD Radio Receiver	List—\$1,100.00	\$990.00
661-DAB	INOmini DAB Plus Receiver	List—\$1,100.00	\$990.00

Small Size, Big Performance

The Inovonics INOmini 300 is a compact, DSP-based 1x3 distribution amp specifically for AES digital audio. It reads and displays digital-signal metadata and features independent metering and audio level control on all outputs.

The INOmini 514 decodes FM-stereo multiplex signals. It accepts a demodulated FM-baseband input and decodes the signal to discrete left and right channel audio. The recovered stereo program is available as a professional line-level balanced output, and also as an AES digital audio signal.



300-00

300-00	AES distribution amp	List—\$790.00	\$711.00
514	FM multiplex decoder	List—\$800.00	\$720.00

RDS MESSAGING SIMPLIFIED

MODEL 732

ADVANCED DYNAMIC RDS/RBDS ENCODER



Inovonics sets a new standard in FM-broadcast radio metadata encoding.

The 732 introduces new features and options that simplify setup and operations, providing improved performance and reliability.

FEATURES

- Dynamic Web Interface for remote control & monitoring
- Security with IP whitelisting for automation data ports
- Flexible Scheduler to program static PS or RT messages
- Alarms and notifications
- SNMP and UDP-multicast support
- RDS Data Delay to match profanity or diversity delays



Call BSW for your best INOVONICS price
1-800-426-8434 • www.BSWUSA.com



Add These Broadcast Processors to Your Arsenal

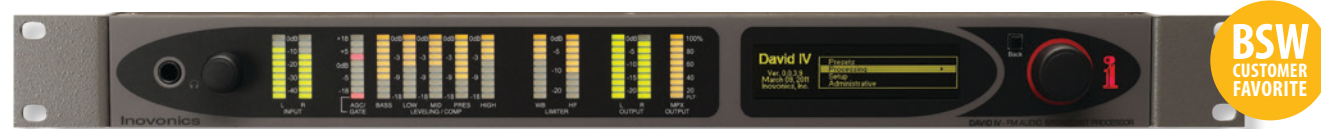

Comprehensive FM or HD Audio Processing with New Network Interface

Inovonics' DAVID IV 719N FM/HD broadcast processor offers powerful, clear sound and an intuitive network Web GUI for easy setup and control. Processing is integrated with a high-performance stereo generator with independent level outputs, and an RDS sync.

- AES3 digital input and outputs (XLR), accepting up to 192 kHz sampling rates

- Left/Right analog inputs and outputs (XLR)
- Adjustable gain-riding windowed AGC with intelligent gating
- 5 Bands of Dynamic Range Compression and Graphic EQ
- Precision FM Stereo generator with dual outputs; RDS sync
- 25 factory presets and 20 customizable presets
- Easy setup and control via front panel or new integrated IP interface

DAVID-IV-N List \$3,500.00 **\$3,150.00**

▶ See the video at bswusa.com/DAVID-IV



Powerful HD Radio Alignment/Delay Processor

Inovonics' JUSTIN 808 maintains time alignment between analog FM and HD1 channels to within 23 microseconds (±1 sample). No more lost words, stuttering, echoes, or level shifts. The entire sync process is 100% automatic. It uses your actual off-air signal and powerful auto-correlation algorithms to keep analog and digital modes faultlessly in step 24/7.

- Automatic phase correction and RMS gain leveling
- Insert in either the FM or HD Radio AES digital feed
- Full Web interface for remote control, metering and more
- SMS/email alarms for loss of signal and loss of audio
- Extensive data logging with graphic display

JUSTIN-808 List \$3,800.00 **\$3,420.00**



NOVIA-FM

NOVIA	Stereo processor 262	List \$1,850.00	\$1,665.00
NOVIA-FM	FM processor 272	List \$2,300.00	\$2,070.00
NOVIA-AM	AM processor 236	List \$2,200.00	\$1,980.00

Innovative Novia Broadcast Processors

The Novia series from Inovonics features three cutting-edge digital audio processors. The Novia 262, designed for FM and stereo production, offers analog, AES and streaming I/O with wideband and FM processing. The Novia 272 handles FM stereo generation and RDS with analog/AES streaming in and MPS/streaming out. The Novia 236 is an AM processor sporting analog, AES and streaming I/O. All give you easy setup and control via PC, tablet or smartphone.

- Gated and windowed gain-riding AGC
- Three bands of dynamic compression with selectable crossovers
- Four sections of parametric EQ plus effective Bass Punch feature
- Adjustable syllabic leveling



INOmini Multimode Audio Processor

Versatile, DSP-based INOmini meets multiple broadcast needs. Features include gated and windowed 'gain-riding' AGC, 3-band compression with adjustable EQ, and a fast 'lookahead' final limiter coupled with overshoot-controlled multi-cutoff output filtering to suit a variety of uses.

223-INOMINI List \$1,100.00 **\$990.00**



NEW

TWO LION UNITS SHOWN IN RACK ADAPTER

LION SHOWN IN RACK ADAPTER

Make Your Processing ROAR with Lion

MAKE YOUR PROCESSING ROAR, the Audioarts Lion, a new FM/HD audio processor gives you superior on-air quality, even from highly compressed source material. To deliver airy highs, a smooth midrange and deep lows you can feel, the half rack sized Lion uses Wheatstone's advanced next-gen multiband AGC and limiting/clipping algorithms developed specifically for today's source content and listening devices. Lion includes stereo enhance, RDS, and supports Wheatstone baseband192 for 192kHz AES3 digital MPX link to the transmitter.

- Absolute peak control with minimal IM distortion
- New and improved Limitless Clipper delivers crisp, clean highs
- Every function in the processing chain educates the other functions in the chain, delivering precision processing when and where needed

- Intelligent stereo enhancement dynamically and artistically optimizes the stereo soundfield
- Bass Management System reveals low frequency nuances in source material for deep, bold low end
- Intelligent AGC achieves perfectly balanced dynamics and presence in any listening environment
- Full suite of static and dynamic RDS features - ingests data from any automation system
- Supports Wheatstone baseband192 for 192kHz AES3 digital MPX link to the transmitter

LION List \$2,500.00*

*Prices too low to advertise. Call BSW for the lowest price 1-800-426-8434.



Streamblade & Wheatstream AoIP Streaming Appliances

Stream up to 8 program channels each capable of four outputs for a total of 32 total output streams. OPUS, MP3 and AAC encoding, stream-specific audio processing and metadata adaptability in one AoIP appliance.

- Streamblade and Wheatstream are all-inclusive Linux and AoIP appliances. No Windows® drivers, updates or PC needed.
- Full suite of audio processing tools developed specifically for streaming.
- Selectable AAC, MP3 and Opus encoders target high to low bit rates for reaching a broad range of end user devices and players. No additional hardware/encoders needed.

- Metadata agnostic. Lua transformation filters adapt metadata input from any automation system into any required output format for streaming of song title, artist and artwork data.
- AoIP appliances. Add Streamblade or Wheatstream to your existing system including WheatNet-IP or any AES67 compatible network.
- Cloud-ready for the future, yet compatible now with standard CDN and streaming platforms. Supports Triton, HLS, RTMP and RTP streaming protocols.

STREAMBLADE-3	Three Input Channels Streaming Blade	List \$12,594.00*
STREAMBLADE-8	Eight Input Channels Streaming Blade	List \$25,194.00
WHEATSTREAM-3	Three Input Channels Streaming No I/O	List \$7,183.00
WHEATSTREAM-8	Eight Input Channels Streaming No I/O	List \$21,414.00

*Prices too low to advertise. Call BSW for the lowest price 1-800-426-8434.

BSW STOCKS MORE INOVONICS THAN ANYONE! 800.426.8434



With hundreds of Wheatstone studios configured, we're experts. Maybe THAT's why our heads are big.

800.426.8434

Justin Warbreck, GearHead
JustinW@bswusa.com





Feature-Rich Digital FM/HD Audio Processor

Wheatstone's X5 offers advanced LIMITLESS technology for ultra-transparent loudness and features an innovative system where all stages of processing are aware of each other. In the X5, the iAGC, limiters and clipper all share information and changes can be made automatically, in real time. Providing full RDS capabilities, the X5 works with third-party HD/FM modulation monitors or by itself with the built-in FM/HD tuner.

- 5 band dynamics processing, 10-band limiter and FM stereo generator
- Independent Bass management tools for each processing path (FM & HD)
- Front panel touch screen and jog wheel for quick setup
- Smart stereo enhancement for a smooth, wide listening experience

AIRAURA-X5 Dual-Path FM HD Digital Audio On-Air Processor List \$90,000.00*

*Prices too low to advertise. Call BSW for the lowest price 1-800-426-8434.



TWO VOICE 1 UNITS IN OPTIONAL RACK ADAPTER

Voice Processor with AES67 and Remote GUI Control

The Audioarts Voice 1 voice processor offers peak vocal performance across the entire vocal range with no undesirable coloration. It features premium mic preamps along with high quality 24-bit A/D converters, and is conveniently compatible with Wheatstone WheatNet-IP audio network.

- Optimized high-frequency EQ, targeted filtering
- High quality 24-bit A/D converters.
- Super Quiet™ mic preamps
- Precision sibilance correction

VOICE1 Processor List \$1,500.00*

*Prices too low to advertise. Call BSW for the lowest price 1-800-426-8434.



MP-532 Multi-Processor One audio processor. Many purposes.

- FM, AM, HD, Streaming audio processor in one rack unit
- Use on-air as an FM/HD or AM/HD processor. Buy one MP 532 for backup to both.
- Full FM RDS capability inside. Save the expense of a separate RBDS/RDS encoder.
- Keep your money and save rack space.
- Multiplex power controller included to reduce adjacent channel interference, saving yet another costly unit to meet the ITU-R BS.412-7 modulation requirements for digital-only stations.

MP-532 List \$4,529.00*

*Prices too low to advertise. Call BSW for the lowest price 1-800-426-8434.



More online! Scan for full specs.



X1 Advanced FM/HD Audio Processor

- Simultaneous FM and HD processor with diversity delay
- iAGC for unprecedented audio consistency
- 5 band dynamics processing, 10-band limiter and FM stereo generator
- Independent Bass management tools for each processing path (FM & HD)
- Front panel touch screen and jog wheel for quick setup
- Smart stereo enhancement for a smooth, wide listening experience
- Insert point for ratings encoders

AIRAURA-X1 FM/HD on-air broadcast processor List \$6,294.00*

*Prices too low to advertise. Call BSW for the lowest price 1-800-426-8434.

See the video at bswusa.com/AIRAURA-X1

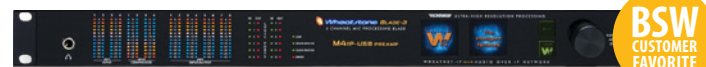

M4IP-USB: Mic Audio Anywhere In Your Facility

The M4IP-USB Microphone Processor Blade combines four high-quality microphone preamps, four channels of embedded microphone processing, four independent USB ports, and a WheatNet-IP Blade interface, allowing you to place four microphone inputs anywhere in your WheatNet-IP Intelligent Network (although it also works just fine as a standalone processor). The preamps and processors are accessed and controlled from any point on the network. The M4 also has the complete set of Blade-3 features.

- Extremely high performance microphone preamplifiers with 48V phantom power
- Four completely independent processing channels
- Phase Scrambler to correct asymmetrical voice waveforms
- TCP/IP-based remote control from anywhere via M4-IP
- Use each processor anywhere on your WheatNet-IP Network
- Four independent USB ports

M4-IPUSB List \$5,630.00*

*Prices too low to advertise. Call BSW for the lowest price 1-800-426-8434.

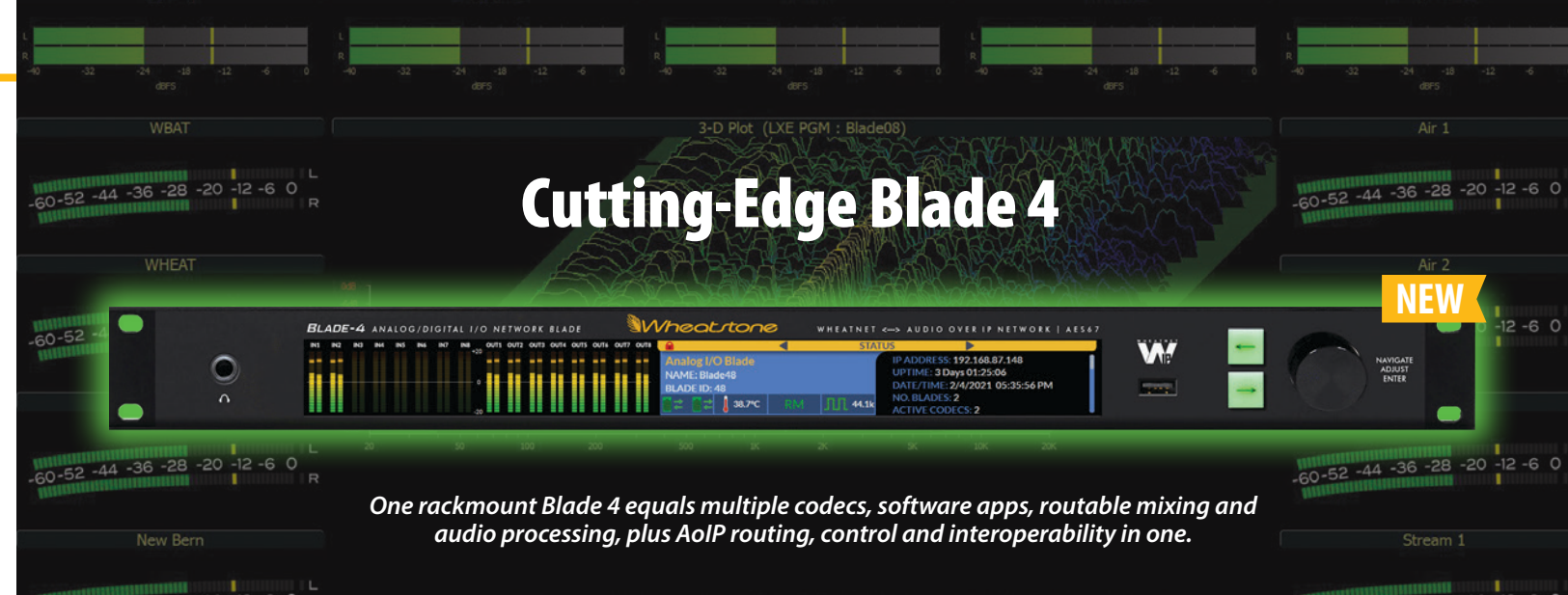

Cutting-Edge Blade 4

One rackmount Blade 4 equals multiple codecs, software apps, routable mixing and audio processing, plus AoIP routing, control and interoperability in one.

Blade 4. Rack Room+ in an AoIP Box.

Blade 4 is Wheatstone's fourth generation WheatNet-IP I/O unit and the most significant AoIP improvement to come out in years. Blade 4 integrates key studio elements into one native AoIP environment, including audio processing, codecs, mixing, routing, control and operating system. It even gives you a built-in OS for running apps and customized scripts for specialized software, metering apps and virtual interfaces. Wow! Call, email or visit BSWUSA for full info.

IP88-4A	Analog Input / Output Blade - 16 Analog Inputs x 16 Analog Outputs, w/ 12 GPIO ports	List \$6,559.00*
IP88-4AD	Analog/Digital Input / Output Blade - 8 Analog, 4 AES Inputs x 8 Analog, 4 AES Outputs	List \$6,559.00
IP88-4D	Digital Input / Output Blade - 8 AES Inputs x 8 AES Outputs, w/ 12 GPIO ports	List \$6,559.00
IP88-4M	8 Microphone Inputs x 8 Analog Outputs, w/ 12 GPIO ports	List \$5,247.00

*Prices too low to advertise. Call BSW for the lowest price 1-800-426-8434.

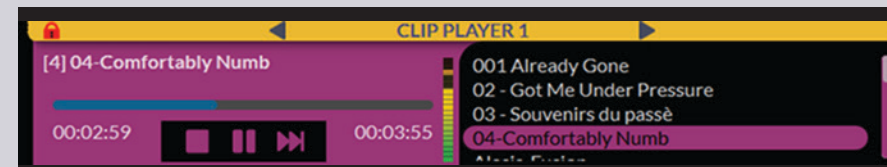

Run select broadcast applications or scripting routines direct from Blade 4. No desktop or laptop or tablet needed.

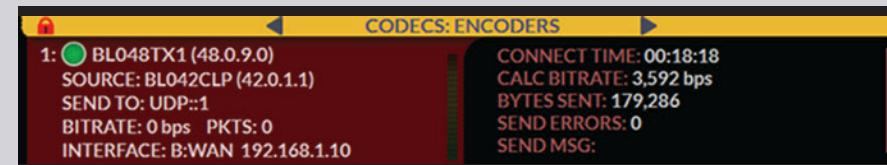

Optional Opus, MP3 and AAC codecs available to add at any time. No additional rack space or other hardware needed.

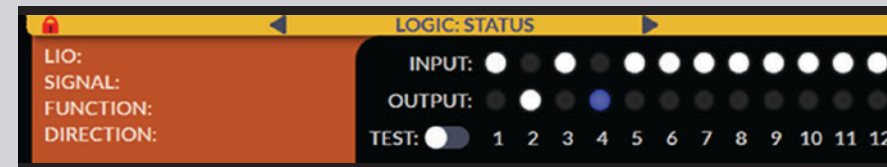

Built-in NMOS for device discovery and AES67 multichannel support and packet timing adaptability, plus interoperability to gear that you've already racked up.

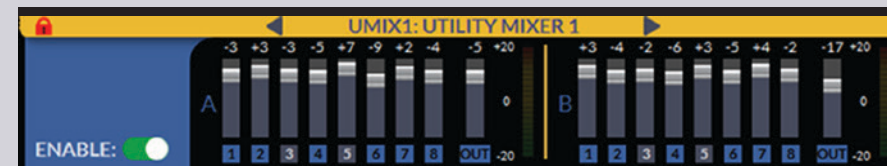

Same Blade features you have come to expect, including routable audio processing and utility mixers.





Our AERO-series processors got an upgrade.

The best just got better.



For more than twenty years, broadcasters worldwide have trusted Linear Acoustic® AERO-series processors to reliably deliver television audio that is pleasing to viewers and compliant with loudness regulations.

The brand-new AERO.20, AERO.200, and AERO.2400 DTV audio processors continue that tradition while adding features like dual independent 3G SDI I/O and AoIP via AES67 for SMPTE ST2110-30 support as well as Livewire+.

Learn More at TelosAlliance.com/AERO

BROADCAST PHONE SYSTEMS
MEASUREMENT AND MONITORING
ON-AIR TV PROCESSING
OEM SOLUTIONS AND PARTNERSHIPS



Call BSW for your best Telos Alliance price
1-800-426-8434 • www.BSWUSA.com

ATSC 3.0/NEXTGEN TV
IP INTERCOM AND COMMUNICATIONS
ENTERPRISE FILE-BASED AUDIO
PROCESSING AND AUTOMATION

Awesome TV Audio From Linear Acoustic



The Legacy of High-Quality TV Audio Processing and Loudness Controls Continues

The all-new AERO.20, AERO.200, and AERO.2400 DTV Audio Processors provide the trusted, audience-pleasing, compliant loudness control and upmixing broadcasters and viewers expect from Linear Acoustic. Features include dual 3G SDI I/O paths for 1080p workflows and AoIP via AES67 for SMPTE ST2110-30 support as well as Livewire+. AERO.20 is a 1RU device with a single processing instance for PCM audio. AERO.200 is a 1RU platform supporting one or two processing instances with optional Dolby® Digital Plus transcoding and Nielsen or Verance audience measurement watermarking. AERO.2400 is a 2RU design with the same capabilities and options as AERO.200 with front-panel controls, a color display, and additional AES3 I/O.

AERO20	One AEROMAX PCM processing instance	List—\$8,495.00*
AERO200	One or two processing instances; automatic upmixing/downmixing	List—\$5,845.00
AERO2400	Adds front panel controls, color display, more I/O	List—\$8,145.00
AEROMAX-AMX20	Three 2-channel processing engines	List—\$4,395.00
AEROMAX-AMX51	One 5.1-channel and two 2-channel audio processing	List—\$5,495.00
AEROMAX-AMX5X2	Five 2-channel processing engines	List—\$4,945.00

*Prices too low to advertise. Call BSW for the lowest price 1-800-426-8434.



Versatile TV Audio Processor

The Linear Acoustic LA-5300 is a versatile broadcast audio processor for TV suitable for ATSC 3.0 and non-ATSC 3.0 applications.

- Loudness control, upmixing, and audience measurement watermarking
- Dolby® AC-4 encoding from PCM for stereo, 5.1, and Dolby Atmos services including ATSC 3.0
- Dolby Digital Plus Encoding with Atmos for delivering immersive audio to streaming services and UHD cable and satellite feeds
- Transcoding from Dolby Digital and Dolby Digital Plus to Dolby AC-4
- Dolby AC-4 and Dolby Digital Plus decoding for bitstream analysis and monitoring

LA-5300	Broadcast Audio Processor	List—\$18,995.00 *
LA-5300-ATSC-UPG	ATSC 1.0 option/upgrade	List—\$3,495.00
LA-5300-NIELSEN	Nielsen watermarking	List—\$3,795.00

*Prices too low to advertise. Call BSW for the lowest price 1-800-426-8434.



AoIP for TV

The Telos Alliance SDI AoIP Node de-embeds and converts up to eight pairs of audio from two SDI inputs to AES67. You can share the audio on the network, process it for loudness compliance, and ultimately re-embed it into two SDI output streams. The SDI AoIP Node is easy to configure. Its user-friendly web-based UI is device-, OS-, and browser-agnostic, and can be used on any desktop or laptop computer, tablet, or smartphone.

SDI-AOIP-NOD	SDI/AoIP node	List—\$5,995.00	\$5,396.00
---------------------	---------------	-----------------	-------------------

CALL BSW FOR THE BEST PRICE ON LINEAR ACCOUSTIC PROCESSORS.
800.426.8434



Ideal Immersive Soundfield Controller

The UPMAX ISC employs a completely new upmixing algorithm, and can upmix 2-channel, 3-channel, 5.1-channel, and 7.1-channel audio to immersive audio formats including 5.1.4 and 7.1.4. Compensating video delay is included to ensure perfect A/V sync regardless of input format or operating mode. For live events and broadcasts, UPMAX ISC can be inserted on a mix bus or placed at the output of the mixing console.

UPMAX-ISC	Soundfield controller	List \$9,995.00 *
------------------	-----------------------	-------------------

*Prices too low to advertise. Call BSW for the lowest price 1-800-426-8434.



Professional TV Audio Encoder

Linear Acoustic LA-5291 Professional Audio Encoder lets you create an exciting and immersive Dolby Atmos experience via a Dolby Digital Plus JOC bitstream for production workflows, platforms, and delivery streams that do not require Dolby AC-4. It offers decoding, encoding, and transcoding to and from PCM and select Dolby coded formats for up to 16 audio channels.

LA-5291	TV audio encoder	List \$18,995.00 *
----------------	------------------	--------------------

*Prices too low to advertise. Call BSW for the lowest price 1-800-426-8434.



Flexible Audio Processing from Jünger



Professional 8-Channel Digital Audio Processor

The Jünger Audio D*AP8 MAP is an 8 channel audio monitoring system, including a comprehensive Dolby® toolkit with metadata emulation and full loudness metering and logging capabilities for up to 40 audio channels. One D*AP8 MAP can replace up to six discontinued Dolby® DP series processors.

- 7.1, 5.1, 3.0, 2.1, Stereo, Mono operation
- Sophisticated monitoring facilities
- 40 channel loudness measurement with logging option
- Dolby metadata generation, processing and emulation
- 4x AES3id I/O
- 2x option board slots for additional interface cards
- 2x Dolby® codec board slot
- Touch optimized web based user interface

2011-00535-000	D*AP8 FLX - 8 Channel Surround Audio Processor	List \$1,485.00 *
2011-00249-000	Level Magic License for D*AP8	List \$1,315.00
2011-00235-000-U	Analog I/O option board for D*AP4 and D*AP8	List \$1,485.00

*Prices too low to advertise. Call BSW for the lowest price 1-800-426-8434.



Amazing I/O Flexibility and Audio Processing Power

The Jünger Audio AIXpressor Multichannel Audio Processing and Interfacing Device includes one instance of Jünger Audio flexAI core license for use as a router and audio format converter for up to 256x256 audio channels in and out. Add optional flexAI engine and processing modules for audio processing configurations.

- On-board interfaces: AoIP (AES67/SMPTE ST2110-30, -31, and -41 metadata), redundant MAD1, analog, and AES3 (AES/EBU)
- Analog and AES3 interfaces with user switchable I/O configurations: 8x8 or 4x12
- 4 slots for optional interface modules (not included). Modules for the following formats are available: 3G SDI, MAD1, Dante, AES3 or Analog
- Zero latency routing of all I/Os up to 3000x3000 connections
- Jünger Audio tieLight cascading interface for up to 1024 channels I/O

- Network based control, configuration and automation
- Full automation with Ember+
- Touch enabled front display operation
- Safety features include power fail bypass relays, dual redundant PSUs and cooling as well as SNMP error reporting
- Sync via MAD1/tieLight, AES3, PTP, Wordclock/Tri-Level/BlackBurst, interface board inputs, and internal clock. Sample rates 44.1 kHz - 96 kHz
- 19" 1RU

2001-00591-000	Audio AIXpressor	List \$7,655.00*
2001-00238-000	Audio Audio-over-IP DANTE™ I/O option board	List \$1,895.00
2001-00235-000	Audio Analog I/O option board	List \$1,485.00

*Prices too low to advertise. Call BSW for the lowest price 1-800-426-8434.



Angry Audio Means Happy Listeners



Low Latency Headphone Processor

The Chameleon C3 is an innovative a low latency multi-band audio processor and high-performance headphone amplifier in one compact and easy to use gadget. Chameleon monitors the incoming audio to your talent's headphones and continuously adjusts its parameters to fit the content. The result is the perfect blend of clean and loud for any format. Your talent will sound amazing in their own ears.

Which will cause them to work their voices and mic technique more effectively. Which in turn will make them sound amazing to your listeners ears. The convenient C3 Bundle adds three Headphone Gizmos.

C3	Headphone Processor	List \$799.00	\$759.00
C3-BUNDLE	Headphone Processor Bundle	List \$1,229.00	\$1,167.00



Superb Streaming Audio Processing and More

The Chameleon C4 is specially designed for streaming audio, making your programming sound consistent even with wildly disparate source material. The Chameleon C4s Livestream Processor utilizes a dynamic decision-making engine to automatically fine-tune your audio in real-time. The Chameleon C6s streaming software app listens to your content, evaluates every nuance in real-time and tweaks parameters to deliver consistent loudness and amazing clarity. The C-Level Chameleon AGC vs. C4 Program Processor works in the audio chain between your console and your over the air processor to deliver transparent, natural sounding audio.

C4	Livestream Audio Processor	List \$999.00	\$949.00
CLEVEL-CHAMELEON	Audio Processor/AGC	List \$999.00	\$949.00



NEW

BUT WAIT... THERE'S MORE AT BSWUSA.COM!

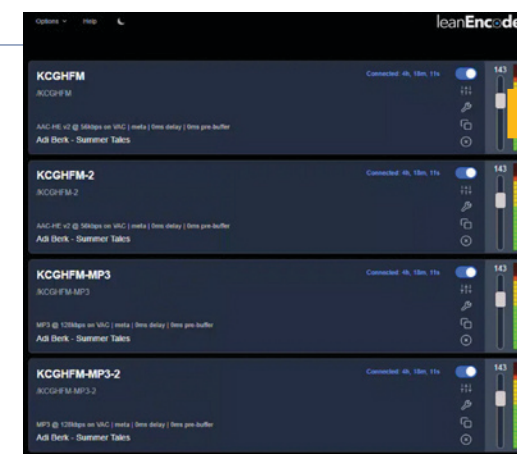

DREAM-ENCODER-STREM

Dream Streams

DreamEncoder professional audio stream encoding software turns any computer into a reliable streaming appliance. It offers remote access with any browser-based device, as well as sophisticated metadata functionality. It lets you create your streams in AAC, AAC+, HE-AAC v2 or MP3 at bitrates from 32kbps to 320kbps. And it's fully compatible with Icecast2, Shoutcast2 and AIS. The DreamEncoder C6S bundle includes the Chameleon C6s streaming software app.

DREAM-ENCODER-C6S	List \$799.00	\$664.05
DREAM-ENCODER-STREM	List \$399.00	\$379.05
CHAMELEON-C4S-PROC	List \$199.00	\$189.05
CHAMELEON-C6S-PROC	List \$399.00	\$379.05

Super-Scalable Wheatstone Consoles



LXE - STARTING AT \$24,000!

Call BSW for the lowest price 1-800-426-8434.

LXE Console

LXE radio console is a flexible, fully customizable control interface. You can program virtually every switch and rotary control to perform any desired function.

- Fully Programmable/Configurable
- LED meters and digital timer, all assignable from ConsoleBuilder™
- True IP – connects directly to switch
- Four stereo Program busses
- Four stereo Aux busses
- Four mono or stereo Mix-Minus busses
- Headphone stream to surface
- Automixing features for mics
- Motorized fader option
- Stereo or mono cue speaker depending on frame size
- Up to 32 physical faders
- Every fader has bus-minus or direct out and is configurable as stereo or mono
- 8 layers (to accommodate up to 32 input fader channels) – completely customizable and configurable for each layer.
- 16 monitors (includes Control Room, Headphones, Studio 1, Studio 2, etc)



More online!
Scan for full specs.



GSX Console

A sister console to Wheatstone's flagship LXE control surface, the GSX has been specially scaled for the modern broadcast studio. GSX integrates with the WheatNet-IP Blade-4 audio network, a complete AES67 compatible network system with end-to-end audio transport, logic control, and an audio toolkit at every I/O point in the network to enable exceptionally intelligent deployment and operation. The GSX is a user-configurable 12 or 24-channel surface with soft switches and controls.

- ConsoleBuilder™ UI for programming the hardware surface
- Optional ScreenBuilder™ UI for creating custom touchscreens
- On-board full-color OLED displays
- Optional Remote GSX client software
- Tap-through graphic menus for setting parameters, triggering presets, storing snapshots of events, and monitoring signals
- Other options will be available for adding functionality to the GSX going forward



More online!
Scan for full specs.

MONITOR NOT INCLUDED



GSX - STARTING AT \$25,000!

Call BSW for the lowest price 1-800-426-8434.

BSW CUSTOMER FAVORITE



L-8

L-12/L-8 Consoles

The L-8 and L-12 are low-profile, completely modular tabletop digital mixing console control surfaces that are scaled for voiceover or news production. They offer assignable sources to any fader with hot-swappable individual fader modules.

- Four stereo output busses
- Stereo cue bus
- Individual Bus-Minus
- OLED source name display
- A/B source selector
- Programmable soft button
- SET button gives access to assignable controls in the master section
- Control room and headphone outputs
- Control and source selection
- Independent studio monitor output
- L-12 has built-in cue speaker

L-8 8-fader on-air console List \$14,795.00*
L-12 12-fader on-air console List \$19,023.00

*Prices too low to advertise. Call BSW for the lowest price 1-800-426-8434.



More online!
Scan for full specs.

BSW CUSTOMER FAVORITE



IP-16

IP-12/IP-16 Console

The IP-12 is a 12-fader digital mixing console control surface and the IP-16 is a 16-fader version. Each input module is equipped with an LED source name display and an A/B source selector; sources can be set via a rotary encoder in the master section.

- Four program busses
- Cue and talkback switches
- Control room, studio, headphone controls
- Source selection
- Headphone jack and amplifier
- Master talkback button
- Built-in cue speaker
- Four event switches
- Six programmable buttons
- Onboard timer

IP-12 12-fader digital radio console List \$11,837.00*
IP-16 16-fader digital radio console List \$15,492.00

*Prices too low to advertise. Call BSW for the lowest price 1-800-426-8434.



More online!
Scan for full specs.

Intelligent, Seamless AoIP with Wheatstone Blades



IP88-4AD

Blade 4 I/O Access Units

Wheatstone's Blade 4 I/O access units for the WheatNet-IP audio network integrate audio codecs, software apps and interoperability protocols with audio transport and control in one compact package. Choose from models with analog I/O, digital I/O, both analog and digital I/O, and microphone I/O.

IP88-4A List \$6,559.00*
IP88-4D List \$6,559.00
IP88-4AD List \$6,559.00
IP88-4M List \$5,247.00

*Prices too low to advertise. Call BSW for the lowest price 1-800-426-8434.

- Full AoIP I/O and intelligence for routing audio, mixing sounds, controlling studio equipment and more
- Two 8x2 stereo utility mixers for online mixing
- IP88-4A: Analog I/O: 16 analog inputs x 16 analog outputs, with 12 GPIO ports
- IP88-4D: Digital I/O: 8 AES inputs x 8 AES outputs, 12 GPIO ports
- IP88-4AD: Analog/Digital I/O: 8 analog, 4 AES inputs x 8 analog, 4 AES outputs
- IP88-4M: Microphone I/O: 8 mic inputs x 8 analog outputs, with 12 GPIO ports



More online!
Scan for full specs.



Nifty Networkable Mix Engine for Wheatstone LXE Consoles

This Blade 4 mix engine for LXE console surfaces seamlessly integrates key audio functionalities (processing, mixing, routing, and control) into your console environment for a more efficient and dynamic audio production workflow. Call, email or visit BSWUSA.com for full info.

IP88-4LXE List \$8,870.00*

*Prices too low to advertise. Call BSW for the lowest price 1-800-426-8434.



Eight Audio Processors in One Networkable Unit

The Aura8-IP audio processing Blade-3 has I/O onboard and eight fully independent multiband stereo audio processors. It offers powerful processing control and network connectivity through the WheatNet-IP Intelligent Network.

AURA8IP-4 List \$7,857.00*

*Prices too low to advertise. Call BSW for the lowest price 1-800-426-8434.



High Quality Mic Processing for Your AoIP Network

The M4IP-USB Microphone Processor Blade combines four high-quality microphone preamps, four channels of embedded microphone processing, four independent USB ports, and a WheatNet-IP Blade interface, allowing you to place four microphone inputs anywhere in your WheatNet-IP Intelligent Network (although it also works just fine as a standalone processor).

M4IP-4USB List \$7,038.00*

*Prices too low to advertise. Call BSW for the lowest price 1-800-426-8434.



GLASS LXE Virtual Console

Virtualization just got a lot more real with Wheatstone's Glass LXE virtual console for its popular WheatNet-IP audio network.

Glass LXE is a touchscreen interface that operates as a standalone virtual console into the WheatNet-IP audio network, a complete IP audio ecosystem of consoles, talent stations, I/O units, accessories and streaming appliances.

Similar in function, feel and layout to the network's flagship LXE hardware control surface, Glass LXE is fully functional and studio-ready as a user interface with familiar buttons, knobs and multi-touch navigation and menuing for setting EQ curves, filtering and other custom settings.

Glass LXE works with the IP-88 LXE mix engine to handle the physical allocation of logic, program busses, mix-minus and monitor outputs.

GLASS-LXE Virtual LXE Console (includes Glass LXE Engine) List—\$13,216.00 *

*Prices too low to advertise. Call BSW for the lowest price 1-800-426-8434.



Handy Talent Stations and More

The TS-22 single panel controller plugs into the WheatNet-IP Intelligent Network to provide controls for mic, headphone, amplifier and speaker levels, all in one turret. Sideboards are great for news rooms or small mixing applications. IP Meters is a GUI for WheatNet-IP that allows the display of an almost limitless array of metering and analysis. ScreenBuilder is an application for creating virtual mixers, talent stations, intercom functions, metering and connection status.

Talent Station Control Surfaces

TS-22-DTM	Desktop Talent Station, simple interface	List—\$2,668.00*
TS-22-CFM	In-desk Talent Station, simple interface	List—\$2,399.00
TS-4H	Tiny Talent Station, simple interface	List—\$928.00

Software

IP-MTR-64	Metering GUI	List—\$1,971.00
ScreenBuilder	App builder for network control	List—\$1,226.00

*Prices too low to advertise. Call BSW for the lowest price 1-800-426-8434.



Blade 3: Intelligent Interface Modules

When Wheatstone invented modern radio audio networking, they vowed to build the first truly intelligent IP audio system. One where every interface held the DNA of the entire system for recovery. A system with true Gigabit connectivity. One that required only a single CAT-6 cable to interface any network piece – to carry audio AND control information. A system that could actually be up 24/7/365 and handle everything you need, yet so simple to interface as to be virtually foolproof. It's only gotten better with time.



More online! Scan for full specs.

Blade-3 Interfaces (all are 1RU):

I/O Blades:

IP88-3A	I/O router with 8x8 stereo analog I/O (16 mono)	List—\$5,247.00*
IP88-3D	I/O router with 8x8 (16 mono) AES-3 digital I/O	List—\$5,247.00
IP88-3AD	I/O router with 4x4 stereo analog, 4x4 AES-3 digital I/O	List—\$5,247.00
IP88-3M	I/O Mic Blade router with 8 XLR mic inputs, 8 analog line-level outputs & selectable phantom power	List—\$5,247.00

Processing Blades:

AURA8IP-3	Aura8-IP - eight channels of processing	List—\$6,285.00
M4-IPUSB	Four-channel mic processor with USB	List—\$5,630.00

Specialty Blades:

MADIBLADE-3	Links 64 channels of MADi audio with WheatNet-IP	List—\$7,096.00
LIO-48	48 universal logic ports	List—\$4,079.00
IP88-SDI-3	SDI audio de-embedder w/4 SD/HD SDI input ports	List—\$7,226.00

*Prices too low to advertise. Call BSW for the lowest price 1-800-426-8434.

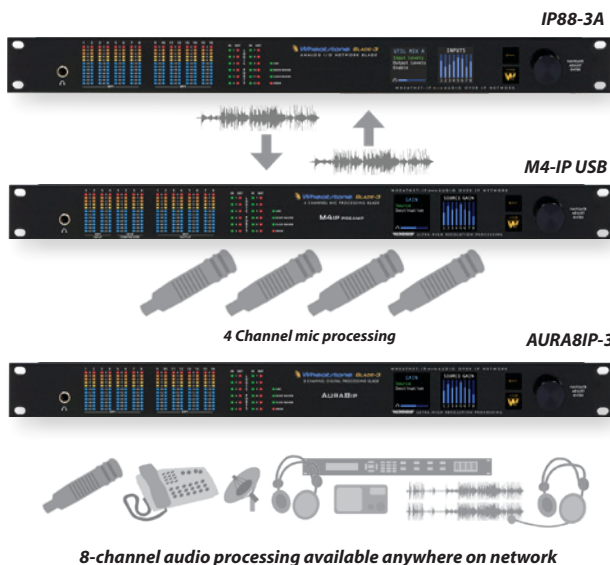

Need to know more on Wheatstone Processing Blades? Visit WWW.BSWUSA.com



Get In on the Action with Axia

Brilliant iQ Consoles

Axia's iQ AoIP console offers easy installation, fast configuration and intuitive operation. Its surface-and-core architecture separates control from mixing processes. No audio passes directly through iQ; all mixing and processing is performed in the QOR.32 Integrated Console Engine so studio "accidents" don't turn into off-air events.

iQx is AES67-compliant and stands fully capable of supporting emerging standards including SMPTE 2110-30. There's virtually no limit to the number of sources and connections you can access on the network.

- Configures from 8 to 24 faders, each with instant access to any source
- Assign any type of source to any channel with a twist of a knob
- 4 main stereo outputs; built-in 3-band per-source EQ
- One-button setup of record mixes for phone bits or off-air interviews
- Use up to 8 automatic mix-minuses simultaneously
- Access all functions remotely using any standard Web browser
- Flexible talkback system lets board op talk to studio guests or any Phone or Codec source with an associated backfeed
- StudioCore integrated console engine combines console power supply, dedicated 5-port AoIP network switch, mixing engine, and audio I/O

2001-00518-000	iQx AES67 console	List—\$5,245.00	\$4,721.00
3002-00084-000	iQx AES67 console remote HTML5 option	List—\$995.00	\$896.00
2001-00275-000	iQ console system 8-fader main frame	List—\$3,645.00	\$3,281.00
2001-00283-000	iQx 8-fader expansion frame	List—\$2,395.00	\$2,156.00



NEW



More online! Scan for full specs.

Think Small, Sound Big with These Axia Consoles

The Axia Radius is an all-in-one console system specially designed for small standalone or networked studios where no more than eight faders are needed. The DESQ console is a cost-effective, small-footprint option perfect for small production studios, remote vehicles, content ingest stations and more. Built for heavy-duty work, the six-fader RAQ rack-mount console provides a convenient way to add a physical mixing surface nearly anywhere.

- 8 faders, each with instant access to any source (Radius)
- Integrated Console Engine performs all mixing and processing (Radius)
- 6 high-quality conductive-plastic faders for smooth operation (DESQ)
- 6 rotary faders and 2 stereo mixing buses and Preview (cue) bus (RAQ)

2001-00273-000	Radius 8-fader console system	List—\$3,645.00	\$3,281.00
2001-00313-000	DESQ IP console	List—\$2,195.00	\$1,976.00
2001-00290-000	RAQ IP console	List—\$1,895.00	\$1,706.00



NEW



Get in The Mix

StudioCore is an integrated console engine for Axia iQ, Radius, RAQ, and DESQ mixing consoles that combines audio I/O, a console power supply, a mixing engine, and a dedicated five-port AoIP network switch with PoE into a single fanless 2RU rack-mounted package.

2001-00635-000	Axia StudioCore + CAN	List—\$7,395.00	\$6,656.00
2001-00636-000	Axia StudioCore + CAN Dual PSU	List—\$7,895.00	\$7,106.00

- 4 selectable mic/line inputs, 8 dedicated line inputs and outputs, and 3 digital inputs and outputs that are user-configurable as AES/EBU, S/PDIF, and USB Audio
- 2 headphone outputs with independent DACs and built-in amplifiers
- Built-in audio file player via USB data port, 4 GPIO ports, and 3 CAN bus ports to provide connectivity with up to three Axia iQ consoles
- Optional second redundant internal power supply



NEW



Recipe for great radio: Add Quasar SR; mix well.



Radio is demanding. "Good enough"...isn't. You've got to be great.

Axia® Quasar™ SR gives talent the tools they need to create the perfect show, every time.

So intuitive, they'll be experts in minutes. With top-tier features like a built-in touchscreen control center, EQ and dynamics processing, per-fader confidence metering, context-aware channel displays, and Show Profiles that instantly recall favorite setups. A world-beating console (with a price that's hard to beat).

Your radio recipe? 1 part talent + 1 part Quasar SR. It's a mix that goes down smooth.



Quasar XR

Delivers even more capabilities to suit even the most demanding applications.



Quasar Engine

The heart of every Quasar studio. Built for rock-solid 24/7 operation.



Call BSW for your best Telos Alliance price
1-800-426-8434 • www.BSWUSA.com

Acclaimed Axia AoIP Consoles Now at BSW!

Out Of This World Quasar Mixing Consoles

Axia's top of the line Quasar XR offers sophisticated workflow features, including powerful DSP audio shaping tools, touch-sensitive faders and more. A large, vivid touchscreen control center gives talent of any technical skill level an ideal interactive mixing experience.

Quasar SR uses the same frame, power supply, and master module as Quasar XR, but the fader modules are non-motorized, and there are fewer, larger, and easier-to-reach buttons on each channel.

- Designed for any size radio studios and specialized TV installations
- Compact and sleek design based on extensive ergonomic studies
- Easy-to-operate touchscreen-based UI
- State-of-the-art DSP processing, available on all channels
- Automixer available on all channels
- All channel strip pushbuttons are user-assignable
- Intuitive Web UI with integrated HTML5 remote control
- Highly flexible audio workflows including auto mix-minus
- Ethernet-connected and self-contained surface modules
- New soft Call Controller switchable from 8 lines to 12 lines



NEW

QUASAR-SR



QUASAR-XR



More online!
Scan for full specs.

QUASAR CONSOLES STARTING AT \$24,000!



NEW

Quasar Engine

Quasar XR and SR surfaces are powered by the Quasar Engine, a native AoIP powerhouse with 16 stereo channels, expandable to 64 channels. Quasar Engine includes four program buses and eight auxiliary buses, four Surface Layers, and a Virtual Mixer (VMix) with 16 independent 5-channel VMixers to extend the mixing capacity of your Quasar console far beyond the physical fader count.

- 4-band fully parametric EQ and powerful dynamics processing including talent headphone processing, True Peak limiting on Program, Record, and

- Phone buses, a dedicated low-latency peak limiter on every input channel
- Variable position insert sends and returns, and automixer on every channel
- Extended AES67 functionality brings full compliance to all engine inputs, outputs, and monitoring sections, and adds PTP synchronization
- Standard redundant power supplies

2001-00584-000 Quasar Engine Base (16 Channel) List \$5,995.00 **\$5,396.00**



NEW

Quasar Engine RPS

Based on our proven Quasar Engine platform, Quasar Engine RPS brings many of the features and functions normally managed by the Master Module found in every Quasar control surface to the engine itself. This makes it possible to create a standalone mixer without the need for an actual XR or SR surface, instead using the browser-based Quasar Soft user interface. It is ideal for situations where a physical console is unnecessary or impractical or as a lower-cost backup to Quasar hardware consoles.

- Includes 16 stereo mixing channels, expandable to 64 channels
- Includes Quasar Soft (for mixing) and Quasar Cast (for low-latency monitoring)
- RPS Upgrade Kit allows standard Quasar Engines to be field-upgraded (does not include Quasar Soft or Quasar Cast)

2001-00581-000 Quasar Engine RPS Base (16-Channel) List \$10,995.00 **\$9,896.00**



Virtual Mixing Made Easy



NEW

3002-00114-801

Searching for a Board OP? Hire Altus!
 Axia's Altus Virtual Mixing Console brings the power and features of a traditional console to computers, tablets, and smartphones. It lets talent contribute, monitor, and control the board easily from a remote location using a laptop or tablet connected to the internet.
 Altus works with both Axia and WheatNet-IP AoIP systems, and is available in subscription and buyout options. Call your friendly neighborhood BSW GearHead for full details.

Virtual Mixing Made Easy The Altus virtual mixing console brings the power and features of a traditional console to computers, tablets, and smartphones running any modern web browser, including full-function mixing, integration with Telos VX® broadcast phone systems, and contribution audio and monitoring via WebRTC. It is ideal for distributed and remote workforces, or anywhere you need to set up a studio quickly and easily. Altus is available as a subscription as well as buyout options. Call, or visit our website for full details.

- Browser-based control (HTML-5) accessible from any device
- Works with any AES67, Livewire+ AES67, or Livewire source
- Configures from 4 to 24 faders, each with instant access to any source

3002-00114-801	Base license, 1 yr subscription	List—\$945.00	\$851.00
3002-00114-000	Base license, buyout	List—\$1,995.00	\$1,796.00
3002-00104-801	WebRTC monitor, 1 yr subscription	List—\$199.00	\$179.00
3002-00104-000	WebRTC monitor, buyout	List—\$445.00	\$401.00
3002-00106-801	WebRTC multi contribution, 1 yr subscription	List—\$350.00	\$315.00
3002-00106-000	WebRTC multi contribution, buyout	List—\$795.00	\$716.00
3002-00105-801	WebRTC single contribution, 1 yr subscription	List—\$199.00	\$179.00
3002-00105-000	WebRTC single contribution, buyout	List—\$445.00	\$401.00



NEW

Axia iQx

Traditionally, mixing surfaces need to be connected to a separate mix engine. iQx breaks that mold by building the mix engine into the surface, meaning fewer connections, less complexity, and a quick and easy installation: iQx simply plugs into your existing AoIP network, where it can access any available networked audio source.
 • Fully AES67 compliant to support SMPTE ST 2110 workflows
 • Affordably priced, but with the build quality you expect from Axia
 • No additional I/O needed to access existing networked audio sources; simply add a Telos Alliance xNode for additional mics or studio sources

2001-00518-000	iQx AES67 Console	List—\$5,245.00	\$4,721.00
----------------	-------------------	-----------------	-------------------



NEW

Flexible Core PRO VML Software

Axia Pathfinder Core Pro VML delivers all the same features as its big brother Pathfinder VM, but at a lower starting price point. It comes with 300 connections (as opposed to VM's 1000 connections), making it ideal for a smaller system with just a studio or two. If the workflow expands, simply apply add-on license points to the server and expand system control.

- Virtualized monitoring and control for Axia Livewire+ AES67 facilities
- Works with familiar, approved hardware
- Can be deployed locally or at an off-site data center
- Comes with 300 points for use as crosspoints or Logic Flow endpoints
- Contact a BSW Gearhead or visit our website for all Core PRO options

3001-00349-000	Pathfinder Core PRO VML	List—\$3,995.00	\$3,596.00
3001-00073-000	Pathfinder Core PRO VM	List—\$6,995.00	\$6,296.00
2001-00515-000	Pathfinder Core PRO broadcast controller	List—\$8,995.00	\$8,096.00
3002-00004-000	Core PRO add-on 100 license	List—\$795.00	\$716.00
3002-00005-000	Core PRO add-on 500 license	List—\$2,995.00	\$2,696.00
3002-00085-000	Core PRO add-on scheduling license	List—\$995.00	\$896.00
3002-00003-000	Core PRO backup	List—\$3,995.00	\$3,596.00
3002-00086-000	Core PRO external authentication feature	List—\$995.00	\$896.00

iProfiler			
3001-00033-100	iProFiler automated program archiving	List—\$995.00	\$896.00

See all options online at BSWUSA.com

Terrific Telos AoIP Nodes



AES-XNODE

Next Generation AoIP Interfaces

The xNode2 lightweight, half-rack, high-performance IP-Audio interface from Telos Alliance is loaded with advanced features and capabilities, including redundant power options. They're fanless, which means they're noiseless too. Versatile mounting options let you deploy two xNode2s in just 1RU of rack space. Dual 1000MB network interfaces are standard, and all xNode2 models are Livewire+ AES67 compliant, including SAP.

- Fully Livewire+ AES67 compliant, including SAP
- High-resolution multi-function front panel color LCD display
- AC power as well as PoE+ when used with compliant Ethernet switch
- SMPTE 2022-7 Seamless Protection Switching

2001-00619-000	xNode 2 Mic	List—\$2,295.00	\$1,975.00
2001-00619-501	Extended warranty		\$189.00
2001-00619-601	Plus 1 year		\$229.00
2001-00619-605	Plus 5 years		\$916.00
2001-00620-000	xNode 2 Analog	List—\$2,295.00	\$1,975.00

2001-00620-501	Extended warranty		\$189.00
2001-00620-601	Plus 1 year		\$229.00
2001-00620-605	Plus 5 years		\$916.00
2001-00621-000	xNode 2 AES	List—\$2,295.00	\$1,975.00
2001-00621-501	Extended warranty		\$189.00
2001-00621-601	Plus 1 year		\$229.00
2001-00621-605	Plus 5 years		\$916.00
2001-00622-000	xNode 2 Mixed	List—\$2,295.00	\$1,975.00
2001-00622-501	Extended warranty		\$189.00
2001-00622-601	Plus 1 year		\$229.00
2001-00622-605	Plus 5 years		\$916.00
2001-00623-000	xNode 2 GPIO	List—\$2,095.00	\$1,795.00
2001-00623-501	Extended warranty		\$169.00
2001-00623-601	Plus 1 year		\$209.00
2001-00623-605	Plus 5 years		\$836.00



StudioEdge

StudioEdge is a high-density endpoint device that combines an abundance of audio I/O and a dedicated five-port AoIP network switch with PoE into a single fanless 2RU rack-mounted package.

2001-00631-000	Axia StudioEdge	List—\$6,445.00	\$5,801.00
2001-00632-000	Axia StudioEdge Dual PSU	List—\$6,945.00	\$6,251.00



xNode Routing Unit

The xSelector combines the routing functions of an XY router control panel with the audio outputs of an Axia xNode. In addition to analog, AES3 and headphone outputs, the Router Selector Node also features an analog and an AES3 input, ideal for production or news studios where operators both create and play audio streams.

2001-00356-000	xNode routing unit	List—\$2,695.00	\$2,426.00
----------------	--------------------	-----------------	-------------------

Awesome IP Audio with Audioarts



More online!
Scan for full specs.



AA-DMX-8



AUDIOARTS INCLUDED MIX-ENGINE

A STUDIO'S WORTH OF I/O!

DMX works with Wheatstone Blades and WheatNet-IP for I/O, routing, processing, and lots of other applications.

Audioarts DMX Ultra-Flexible AoIP Networkable Console

Audioarts' DMX consoles feature full compatibility with WheatNet-IP and Blades to deliver ultra-flexible AoIP networking and expansion. The included Audioarts Mix Engine sports balanced XLR mic preamp inputs and RJ45 connectors for all other audio, logic and network connections. It offers full AES67 compatibility. You don't need an external switch to create or join an existing WheatNet-IP system, making DMX one of the more affordable entry-level IP audio networked consoles on the market.

- Standalone/networkable production or on-air console with local or remote I/O
- 8 (DMX-8) and 16 (DMX-16) input faders
- Audioarts Mix Engine: 2 mic inputs on XLRs; 4 analog I/O, 4 digital I/O, and 2 analog mic outputs on RJ-45s
- 5-port gigabit Ethernet switch built into Mix Engine
- WheatNet-IP - any source to any fader
- 4 program output busses
- 4 event buttons for recalling entire console setups
- Full EQ functions on each channel
- Talkback and cue functions; 6 logic GP I/O ports for network control
- Optional Blade interfaces can expand system I/O and functionality

AA-DMX-8 List \$8,505.00*
AA-DMX-16 List \$12,915.00

*Prices too low to advertise. Call BSW for the lowest price 1-800-426-8434.



AA-DMX-16

15-ISH SECONDS CAN SAVE YOU HUNDREDS – CALL BSW FOR BEST PRICE! 800.426.8434



More online!
Scan for full specs.



Top Functionality in a Compact Console

The Audioarts AIR-4 radio console delivers superb broadcast quality and an extensive feature set at a great price. Boasting four built-in microphone preamps, 12 input faders (with A/B source select), a 13th fader for call-ins, external machine control, two program busses, built-in cue speaker and Control Room, headphone and studio monitoring control as well as patchable USB connectivity for PC news, production workstations or streaming audio, the AIR-4 is the ideal console for local radio stations and internet broadcasters.

And with basic features like machine control, cue, talkback, and mix-minus included, it's perfect for smaller stations looking to upgrade as well as for larger facilities in need of an auxiliary studio or newsroom console.

AIR4 List \$6,371.00 *

*Prices too low to advertise. Call BSW for the lowest price 1-800-426-8434.

- 12 stereo input fader channels and A/B source select
- 13th phone caller fader with Talk Back and automatic mix-minus to caller
- Remote START logic for each fader
- Four precision microphone preamps
- Two program busses with balanced outputs (switchable stereo or mono mode)
- Studio output with independent source selection and Control Room to studio Talk Back button
- Switched VU meters
- Electronic switching
- LED illumination
- Tabletop Mount
- Cue speaker
- Headphone jack with built-in amplifier
- External input feeds the monitor section (for live air or pre-delay air monitoring)
- USB connection
- RJ45 connectors for low cost wiring



Compact Audio Console with USB

The compact Audioarts AIR 1 USB eight-channel audio console has everything you need for on-air, production, news applications, remotes, podcasting and more. Its bidirectional USB audio port offers convenient interfacing to computers and automation systems.

- 8 input faders
- 6 stereo input channels; 2 microphone input channels
- Dual program busses (can be stereo or mono sum)
- Dual, super-quiet, high performance microphone preamps
- Separate control room monitor and headphone outputs
- LED illumination on all switches
- Built-in headphone amplifier with +20dB output

AIR1 List \$3,455.00*

*Prices too low to advertise. Call BSW for the lowest price 1-800-426-8434.



Get your DMX from BSW, the home of larger than life gear heads!

800.426.8434

Bryan Seeley, GearHead
BryanS@bswusa.com





AML-8-AZALEA

This Little Number Has It All!

Not just another analog face lift, the new AML 8 is re-engineered from the inside out to pack modern features into its compact size and price.

- Full, 100mm throw faders with separate on/off buttons
- USB port for automation, laptops, and other modern feeds
- Super Quiet™ mic preamps for low noise
- External power supply built by Wheatstone to extend the life of your console
- Built-in headphone amp with split cue, and more...
- All for less than the cost of a laptop

AML-8-AZALEA 8-fader analog console List—\$1,500.00 *



More online! Scan for full specs.



DML-12-LYRIC

New Sporty Compacts

The new Audioarts Lyric DML 12 and Verse DML 8 are plug-in ready digital consoles in a sleek, one inch thin tabletop profile. They offer USB direct-to-fader input(s), (plus Bluetooth in the case of the DML 12), for PCs, phones, players and other external devices. Direct digital output to a WheatNet-IP audio network is available via an optional WheatNet-IP app. Both models feature three stereo program busses, AES3 inputs via RJ45, mic preamp(s) and a built-in cue speaker.

- 8 (DML-8); 12 (DML-12) input faders
- 2 mic level (DML-8); 4 mic/mono line (DML-12) input faders
- 5 (DML-8); 7 (DML-12) AES digital stereo input faders
- 1 caller fader with mix-minus (DML-8)
- 1 Bluetooth caller input/output fader (DML-12)
- 1 (DML-8); 2 (DML-12) USB input faders
- 2 VU (DML-8); 3 VU (DML-12) meter bridge
- 3 stereo program busses; 1/8" headphone jack (both models)
- AES3 inputs via RJ45; mic preamp(s); built-in cue speaker (both models)
- On-Air tally; external power supply and cable (both models)

DML-8-VERSE 8-fader digital console List—\$5,000.00 *
DML-12-LYRIC 12-fader digital console List—\$6,000.00

Accessories:

DML12-ADPT-K DML-12 adapter kit List—\$265.00 *
DML8-ADPT-K DML-8 adapter kit List—\$200.00

*Prices too low to advertise. Call BSW for the lowest price 1-800-426-8434.



LIGHTNING-16

Live Radio Hybrid Analog/Digital Mixer with Bluetooth, USB, and AES

Audioarts' Lightning is a standalone, mid-sized analog console offering 12- and 16-channel configurations with USB and Bluetooth connectivity for extra versatility. It's ideal for studios that have mostly mic or analog source inputs and where a lot of studio routing isn't required. A patchable AES input lets you connect a digital source to any fader, and it boasts built-in A/D conversion for the main program output.

- 12- or 16-channel tabletop configurations with flexible modular design
- 4 mic preamps; 4 stereo program busses; 2 auto mix-minuses for call-ins
- USB and Bluetooth connectivity for playing audio directly from a PC
- Patchable AES input lets you connect a digital source to any fader
- Built-in A/D conversion for the main program output

LIGHTNING-12 12-channel console List—\$9,824.00 *
LIGHTNING-16 16-channel console List—\$10,184.00

*Prices too low to advertise. Call BSW for the lowest price 1-800-426-8434.



More online! Scan for full specs.

BSW CUSTOMER FAVORITE

Virtual Console Packages with High-Performance Audio Interfaces

The Arrakis DARC Virtual ASIO Pro bundle features a dynamic software console boasting 8 channels, 18 mono inputs, and 20 mono outputs. It offers software assignable inputs, allowing you to configure your sources as mono or stereo. You can conveniently switch between individual source inputs or use user presets. You also get the Behringer ADA8200 ADAT audio interface, featuring ultra-accurate, reference-class Cirrus Logic A/D - D/A converters and 8 award-winning Midas-designed mic preamps.

- DARC Virtual 8 Console software license
- Behringer ADA8200: 8 In/8 Out ADAT audio interface with ADA converters and Midas mic preamps
- Not included: Windows PC

The DARC Virtual ASIO Lite bundle is a dynamic software console featuring 4 channels, 10 mono inputs, and 12 mono outputs. It offers software assignable inputs, allowing you to configure your sources as mono or stereo. You can conveniently switch between individual source inputs or use user presets. You also get the Behringer U-PHORIA UMC1820 USB 2.0 audio/MIDI interface sporting 8 Midas preamps.

- DARC Virtual 4 Console software license
- Behringer UMC1820: 18x20, 24-Bit/96 kHz USB Audio/MIDI interface
- Not included: Windows PC

DARC-ASIO-LITE 10 mono inputs / 12 mono outputs List—\$950.00 *
DARC-ASIO-PRO 18 mono inputs / 20 mono outputs List—\$1,700.00

*Prices too low to advertise. Call BSW for the lowest price 1-800-426-8434.



DARC-ASIO-PRO



Real-World Digital AoIP Console/Controller

The Arrakis DARC Surface is a physical interface designed to control the DARC Virtual software console, giving you the benefits of a software console, but with the ability to use a real world control surface. DARC Surface can control any Dante network audio source. Delivering a pure RF-free signal, it lets you mix, adjust levels, and do everything you need for an On-Air or production room console. All stereo inputs and outputs on the Simple IP are also balanced for RF resistance.

The DARC Surface is available in three models with 8, 12, or 16 input channels. Packages include a DARC virtual software license and an Arrakis Simple-IP unit for connecting any analog (A models) or digital audio sources (D-models) to the Dante network.

DARC-SUR-12A 12ch Surface, DARC Virtual software license, 3 Simple IP 8 A List—\$5,200.00 *
DARC-SUR-8A 8ch Surface, DARC Virtual software license, 2 Simple-IP 8 A List—\$3,700.00
DARC-SUR-8-ASIO Surface-8, DARC Virtual software license, UMC1820, ADA8200 List—\$3,700.00
DARC-SURFACE-12 Surface-12, DARC Virtual (Dante/ASIO audio source required) List—\$3,499.00
DARC-SURFACE-8 Surface-8, DARC Virtual, Dante/ASIO audio source required) List—\$2,899.00

*Prices too low to advertise. Call BSW for the lowest price 1-800-426-8434.



DARC-SURFACE-12

Powerful DARC Virtual Console Software

Arrakis' DARC is an intuitive, powerful virtual software mixing console, capable of either utilizing Dante AoIP or an off the shelf ASIO soundcard. Dante and ASIO are required. PC not included.

- Dynamic source switching that allow you to connect up to 64 input sources
- 8 Phone mix-minus busses to connect to eight phone hybrids
- Stream and record individual channels, post fader (great for podcasting)
- Control multiple faders at the same time with 10-point multi-touch

DARC-TOUCH Touchscreen monitor List—\$700.00 *
DARC-VIRT-12A 12 ch DARC Virtual software + 3 Simple IP 8-A List—\$4,000.00
DARC-VIRT-12SOFT 12ch Virtual Software (Dante/ASIO Soundcard Required) List—\$1,000.00
DARC-VIRT-16A 12ch DARC Virtual software + 4 Simple IP 8 A List—\$5,100.00
DARC-VIRT-16SOFT 16ch DARC Software (Dante/ASIO soundcard required) List—\$1,200.00
DARC-VIRT-4A 4-ch Console, DARC Virtual software + 1 Simple IP 8 A List—\$1,900.00
DARC-VIRT-4SOFT 4ch DARC Software (Dante/ASIO Soundcard Required) List—\$500.00
DARC-VIRT-8A 8-ch Console, DARC Virtual software + 2 Simple IP 8 A List—\$3,100.00
DARC-VIRT-8SOFT 8ch DARC Software (Dante/ASIO soundcard required) List—\$800.00
DARC-VIRTUAL Virtual Console software, Dante AoIP console software List—\$1,000.00

*Prices too low to advertise. Call BSW for the lowest price 1-800-426-8434.



DARC-TOUCH

Analog and Digital Hybrid Consoles

Get the best of both worlds, and don't settle for less.

For more than 40 years, Arrakis Systems has led the way with groundbreaking innovations — USB, Bluetooth, AoIP with Dante, and now software-controllable analog consoles. It's time to treat yourself while still getting value from your boards. Starting at only \$699, there is a board for every scenario.



DARC Virtual
4 - 16 Channels - AoIP software console

DARC Surface
8 Channel or 12 Channel - AoIP console



ARC-5 5 Channel 1 Stereo Output Bus	ARC-8 8 Channel 1 Stereo Output Bus	ARC-Talk-Blue 8 Channel 1 Stereo Output Bus
--------------------------------------------------	--------------------------------------------------	----------------------------------------------------------

ARC-10 Series 10 Channel 2 Stereo Output Buses	ARC-15 15 Channel 2 Stereo Output Buses
-------------------------------------------------------------	------------------------------------------------------



H15 Series
15 Channel - 2 Stereo Output Buses
Software controllable



MARC Series
15 Channel - 3 Stereo Output Buses
Modular analog, up to 30 (A/B) inputs.



H10 Series
10 Channel - 2 Stereo Output Buses
Software Controllable

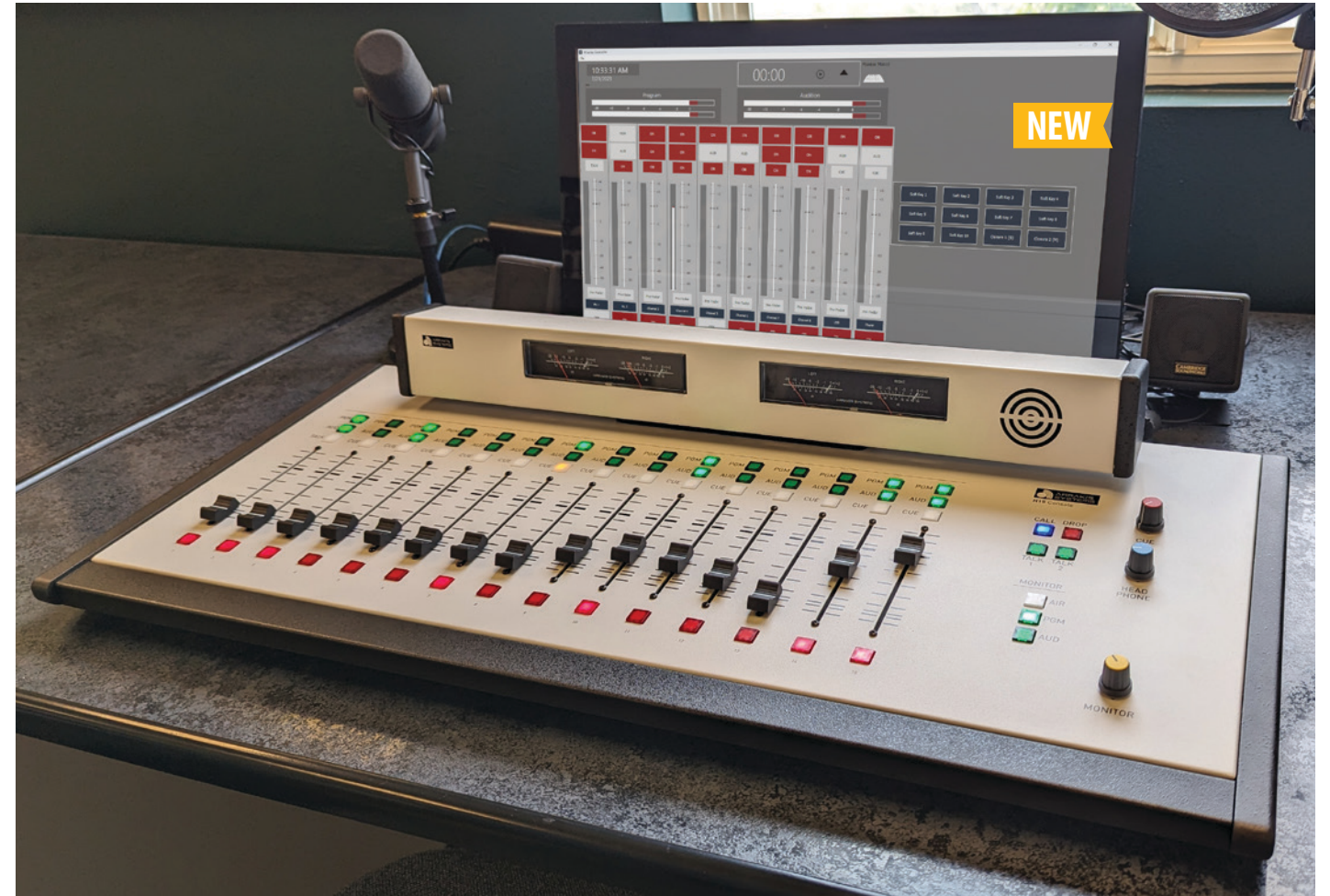

H-15

Loaded Software-Controllable Broadcast Consoles

The H10 mixing console offers the best of both worlds, combining the simplicity, reliability, performance, and ease of operation of analog with the flexibility and power of digital technologies. It's a perfect blend of traditional and modern features, delivering an exceptional audio experience for all users. H-Series Controller software is included, letting you control the console remotely from anywhere in the world. With this software, you can easily turn channels on or off, monitor input levels, and utilize user presets to swiftly switch between different profiles, ensuring a seamless and efficient audio management experience. The H10-LED adds LED VU meters for real-time audio monitoring and precise signal clarity.

The new H15 features one to five built-in mic preamps assignable via dip switch on rear of console, seven to 12 stereo line inputs (both balanced RJ45 or unbalanced RCA inputs), USB for playback and record (Mac and Windows), two phone mix-channels, and Bluetooth. With this feature, you can easily connect your smartphone to put callers on-air or stream recordings with ease.

The H15 is meticulously designed for reliability, offering long-lasting performance and easy maintenance with socketed ICs. Its switches and faders are engineered to endure multi-million operations, ensuring flawless functionality in critical environments. Skilled technicians can breeze through maintenance thanks to accessible components, while the user-friendly interface allows for easy operation by anyone. The H15 features both balanced and unbalanced inputs and outputs, making it highly effective at resisting RF interference for a clean broadcast. The balanced inputs utilize RJ45 connectors.

H10 Features:

- 10 Channels, 2 output busses
- 2 built-in mic channels
- 7 stereo line in
- 1 USB
- 1 Phone
- 1 Bluetooth (standard)
- XLR balanced and RCA unbalanced outputs
- Balanced RJ45 connectors
- Software controllable via the H Series Controller
- Choose from analog or digital LED meters

H-10	H-Series Controller software	List \$3,299.00 *
H-10-LED	H-10 with LED meters	List \$3,299.00
H-15	15-channel broadcast console	List \$4,599.00

*Prices too low to advertise. Call BSW for the lowest price 1-800-426-8434.



Connect with Arrakis Consoles



"We use the Arrakis ARC-8 for our low power FM radio station, it's a great product for the price. Professional looking, clear sound easy to use."

★★★★★ ARC-8

News Talk Console with Bluetooth Phone Channels

The revolutionary Arrakis ARC-Talk-Blue radio console features five mic, one USB and two Bluetooth phone channels, making it a great choice for news talk applications. Compact

- Eight input channels: five XLR mic, one USB, two Bluetooth
- High performance mic preamps
- Stereo output bus
- LED illuminated switch lamps
- Connect your phone using the Bluetooth channels
- Connect your tablet wirelessly to play audio over the air
- Play audio from your USB device directly through the board
- Play and record in digital with Windows PC or Mac
- Record audio from your board using any 3rd party software
- Active balanced RJ-45 and unbalanced RCA

yet rugged, it's also ideal for remote broadcasts and production studios. The ARC-8 blue's lone Bluetooth channel lets you connect to any Bluetooth enabled device. The ARC-8 is a versatile, affordable console.

ARC-TALK-BLUE	News talk console	List \$1,299.00 *
ARC-5	5-channel, bal & unbalanced w/USB	List \$749.00
ARC-8	8-channel	List \$1,049.00
ARC-8-BLUE	8-channel with Bluetooth	List \$1,299.00
ARC-10U	10 channels, unbalanced I/O	List \$1,999.00
ARC-10U-ARC-BLUE	ARC-10U with Bluetooth amp	List \$2,299.00
ARC-10UP	ARC-10U with USB	List \$2,349.00
ARC-10UP-ARC-BLUE	ARC-10UP with Bluetooth amp	List \$2,649.00
ARC-15	15-channel broadcast console	List \$4,299.00
ARC-15BP-BLUE	15-channel bal console with Bluetooth & USB	List \$4,599.00

*Prices too low to advertise. Call BSW for the lowest price 1-800-426-8434.



BSW and Arrakis, Together for 35+ Years!
A Mix You can Trust



Console with Flexible I/O Configurations

The Arrakis MARC-15 modular analog console is a single 15-channel mainframe with a wide variety of optional module configurations. All switches are LED illuminated and all ICs are socketed (not surface mount) for reliability. The meter panel hinges up and back for access to I/O connectors and trimpots. All I/O is by RJ45 connectors. The meter panel contains meters for all three busses, a digital timer, and a built in cue/talkback speaker.

You can configure the 8-, 12- and 15-channel mainframe models with your choice of modules. Available modules include: Mic Module, Stereo Line Module, PC USB Module, Phone Module and Studio Monitor Module. Call or email BSW for full information.

- 3 stereo program output mixes plus monitor headphone, and cue systems
- Real VU meters monitor all three output buses
- Cue-talkback system with built-in amplifier and speaker
- Built-in timer with manual and automated control

MARC-15-8	8 input modules (specify when ordering)	List \$5,925.00*
MARC-15-12	12 input modules (specify when ordering)	List \$6,499.00
MARC-15-15	15 input modules (specify when ordering)	List \$7,475.00
Accessories:		
MARC-MIC	Mic Input Module	List \$525.00
MARC-STL	Stereo Line Input Module	List \$525.00
MARC-PHN	Phone Input Module	List \$525.00
MARC-USB	PC-USB Input Module	List \$525.00
MARC-STM	Studio Monitor Module	List \$525.00
MARC-BLU	Bluetooth Module	List \$650.00
MARC-OB	Output Module Board	List \$850.00
MARC-BLK	Blank Module	List \$125.00

*Prices too low to advertise. Call BSW for the lowest price 1-800-426-8434.

Awesome Angry Audio Radio Console



NEW

RAVE-PKG



Remarkable RAVE! Radio Mixing Console

Angry Audio's RAVE! radio mixing console offers up to eight stereo line inputs, up to four microphone inputs, two output mix buses, two mix-minus outputs with talkback, flexible monitoring for the board operator, monitor feed to studio guests with talkback, automatic monitor muting when the mics are open, crystal clear metering and tallies and much more.

The RAVE Bundle has the RAVE! console and StudioHub Cables/Adapters Kit. The RAVE Super Bundle boasts the RAVE! console, StudioHub Cables/Adapters Kit, and Angry Audio Gadget/Gizmo Kit. All consoles come with a power supply.

RAVE-PKG	Console w/ power supply	List \$2,199.00*
RAVE-BUNDLE-PKG	Console w/Cables/Adapters Kit	List \$2,699.00
RAVE-SUPERBUNDLE-PKG	W/ Cable/Adapter, Gadget/Gizmo kits	List \$3,699.00

*Prices too low to advertise. Call BSW for the lowest price 1-800-426-8434.

CALL BSW FOR BEST PRICE! OPERATORS ARE STANDING BY!
(OK, THEY'RE PROBABLY SITTING). 800.426.8434



NEW

CAPITOL-IP



NEW

CAPITOL-IP-CS

Ultra-Compact Digital Audio Mixer

CAPITOL-IP is an ultra-compact digital audio mixer for radio and television with a desktop control surface and associated audio engine. The desktop control surface features a control section and 8 fader channels and Mcore Audio Mixer engine. IP connectivity is implemented through a single module with 16 input and 16 output channels incorporated in its core, and excludes MADI connectivity. CAPITOL IP consoles can have a single multichannel access: IP or MADI. Configuration options offer ethernet connectors or the MADI optical connector, or without either of these, but never with both at the same time.

CAPITOL-IP	Desktop digital audio mixer	List \$7,245.00 *
CAPITOL-IP-CS	Countersink version	List \$6,760.00

*Prices too low to advertise. Call BSW for the lowest price 1-800-426-8434.

- Desktop and countersink versions
- 4 mic/line inputs
- 4 stereo AES/EBU digital audio I/O (possible to set up as SPDIF)
- 12 mono analog inputs (possible 6 stereo)
- 2 USB stereo digital inputs and outputs
- 4 stereo AES/EBU digital audio outputs (possible to set up as SPDIF)
- 8 mono analog inputs (possible 4 stereo)
- Single power supply
- Not included: Dante AoIP module, telephone hybrid module, MADI module



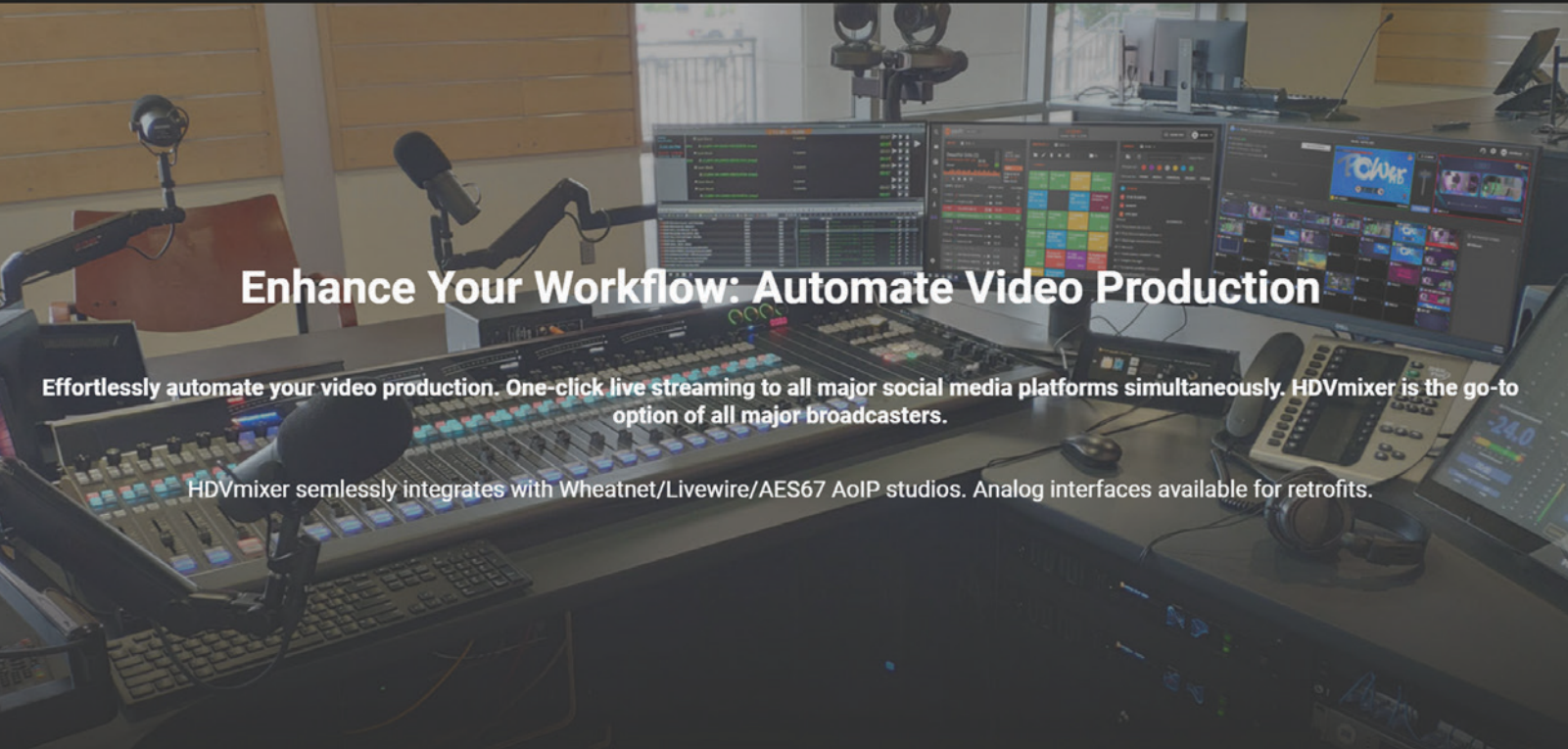

Enhance Your Workflow: Automate Video Production

Effortlessly automate your video production. One-click live streaming to all major social media platforms simultaneously. HDVMixer is the go-to option of all major broadcasters.

HDVMixer seamlessly integrates with Wheatnet/Livewire/AES67 AoIP studios. Analog interfaces available for retrofits.

Why choose HDVMixer?



Stream live and record in HD or 4K

To all major social media platforms and CDNs. Up to 25 SRT/RTMP destinations with SCTE-35 for Dynamic Ad Insertion.



Invite guests and co-hosts

Just send them a link to join.



Automate video production

Using AI based technology



Web UI for ease of operation

Monitor and control any of your studios from a unified web panel.

How does HDVMixer work?



1 Install

Install any of our video production solutions in your current studio.

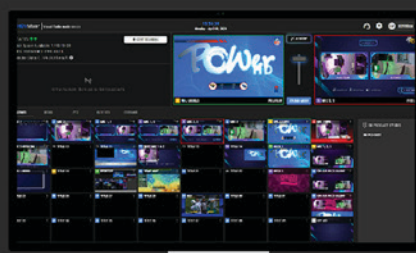

2 Train HDVMixer

Tell the AI how you need the automated video production to look.



3 Go Live!

Produce video content with minimal effort. Go live with one-click on multiple social media platforms at once. Record content for reels easily.

Visual Radio and Automation Packages



HDVMixer Packages Make Visual Radio Easy

These exclusive HDVMixer hardware/software packages for small to mid to large stations give you the tools you need to add audience-grabbing video to your radio programs along with full social media integration. Contact a BSW GearHead or visit the new BSWUSA.com for more information.

- Up to 15 video sources with NDI/SDI/HDMI support
- AirLink remote HD broadcast links for co-host/guests
- Automate social media streaming up to 25 destinations
- Automate video production with AI
- Web UI for ease of operation
- Stream live and record in HD or 4K

HDV-FULL	Rackmount server, HDVMixer and 5 PTZ cameras	List \$22,873.46*
HDV-MID	Rackmount server, HDVMixer and 4 PTZ cameras	List \$18,989.46*
HDV-LITE	4-input podcasting video software	List \$1,298.70*
HDV-WSN-16P	Rackmount PC, 64GB RAM (monitor not included)	List \$5,895.00*
HDV-WSN-16	Rackmount PC, 32GB RAM (monitor not included)	List \$4,599.00*

*Prices too low to advertise. Call BSW for the lowest price **1-800-426-8434**.
*Requires annual renewal.



Radio Automation Simplicity for the Hybrid Workplace

Insoft's 5th generation radio automation gives you total flexibility with an on-premise server and remote browser access. Its user interface is remotely accessible from any device, and it enables a cloud-based connection to remote clusters of stations. Shielded by design from virus and malware attacks, it also offers IP-based syndicated content distribution. Insoft's personalized tech support and training is the icing on the cake.

- Browser accessible media assets management
- Automated reporting, traffic reconciliation and audit of stations
- Build-in music scheduler or bring your own
- Build-in traffic scheduler or bring your own
- Automated reporting, traffic reconciliation and audit of stations
- Mission critical reliability with 1+1 hot-standby (optional)

IN-MCP	Rackmount playout server with INSOFT radio automation software, on-air and production licenses	List \$1,485.00*
IN-TR	SpotMASTER cloud based traffic scheduling software	List \$990.00*

*Prices too low to advertise. Call BSW for the lowest price **1-800-426-8434**.
*Requires annual renewal.





More online!
Scan for full specs.

Modular Styles For Every Job

7'2" x 4' QL2PKG1-SIT-FM QL2PKG1-STD-FM
1 Below counter rack
AS ABOVE, SHOWN FLIPPED

7'2" x 4'10" QL2PKG2-SIT-FM QL2PKG2-STD-FM
2 Below counter racks
AS ABOVE, SHOWN FLIPPED

7'2" x 6'6" QL2PKG3-SIT-FM QL2PKG3-STD-FM
3 Below counter racks
AS ABOVE, SHOWN FLIPPED

8'10" x 6'8" QL2PKG4-SIT-FM QL2PKG4-STD-FM
3 Below counter racks
2 Position Guest-Wing
QL-4
AS ABOVE, SHOWN FLIPPED

7'2" x 5'8" QL2PKG5-SIT-FM QL2PKG5-STD-FM
1 Below counter rack
2 Position Guest-Wing
AS ABOVE, SHOWN FLIPPED

7'2" x 6'7" QL2PKG6-SIT-FM QL2PKG6-STD-FM
2 Below counter racks
2 Position Guest-Wing
AS ABOVE, SHOWN FLIPPED

7'2" x 8'3" QL2PKG7-SIT-FM QL2PKG7-STD-FM
3 Below counter racks
2 Position Guest-Wing
AS ABOVE, SHOWN FLIPPED

8'10" x 8'3" QL2PKG8-SIT-FM QL2PKG8-STD-FM
3 Below counter racks
4 Position Guest-Wing
AS ABOVE, SHOWN FLIPPED

8'8" x 5' QL2PKG9-SIT-FM QL2PKG9-STD-FM
1 Below counter rack
2 Position Guest-Wing
AS ABOVE, SHOWN FLIPPED

8'8" x 5' QL2PKG10-SIT-FM QL2PKG10-STD-FM
2 Below counter racks
2 Position Guest-Wing
AS ABOVE, SHOWN FLIPPED

8'8" x 6'6" QL2PKG11-SIT-FM QL2PKG11-STD-FM
3 Below counter racks
2 Position Guest-Wing
AS ABOVE, SHOWN FLIPPED

10'4" x 6'6" QL2PKG12-SIT-FM QL2PKG12-STD-FM
3 Below counter racks
4 Position Guest-Wing
AS ABOVE, SHOWN FLIPPED

8'8" x 6'8" QL2PKG13-SIT-FM QL2PKG13-STD-FM
1 Below counter rack
4 Position Guest-Wing
AS ABOVE, SHOWN FLIPPED

8'8" x 6'8" QL2PKG14-SIT-FM QL2PKG14-STD-FM
2 Below counter racks
4 Position Guest-Wing
AS ABOVE, SHOWN FLIPPED

8'8" x 8'3" QL2PKG15-SIT-FM QL2PKG15-STD-FM
3 Below counter racks
4 Position Guest-Wing
AS ABOVE, SHOWN FLIPPED

10'4" x 8'3" QL2PKG16-SIT-FM QL2PKG16-STD-FM
3 Below counter racks
6 Position Guest-Wing
AS ABOVE, SHOWN FLIPPED

SIT= sit down height • STD= stand up height



Wheatstone's QuickLine Modular Studio Furniture

QuickLine studio furniture delivers Wheatstone ergonomics and comfort in modular, quick-ship configurations for real flexibility with easy setup. Choose from 32 functional configurations using only five modular components. Call, or visit BSWUSA.com for more information and complete specs.

QL2PKG13-STD-FM	8' 8" x 6' 8" STANDUP	List \$4,278.00*
QL2PKG10-SIT-FM	8' 8" x 5' SITDOWN	List \$4,390.00
QL2PKG16-STD-FM	10' 4" x 8' 3" STANDUP	List \$6,496.00
QL2PKG13-SIT-FM	10' 4" x 8' 3" SITDOWN	List \$6,261.00
QL2PKG15-STD-FM	8' 8" x 8' 3" STANDUP	List \$5,790.00
QL2PKG15-SIT-FM	8' 8" x 8' 3" SITDOWN	List \$5,645.00
QL2PKG1-STD-FM	7' 2" x 4' STANDUP	List \$2,985.00
QL2PKG14-SIT-FM	8' 8" x 6' 8" SITDOWN	List \$5,018.00
QL2PKG2-SIT-FM	7' 2" x 4' 10" SITDOWN	List \$3,786.00
QL2PKG13-SIT-FM	8' 8" x 6' 8" SITDOWN	List \$4,116.00
QL2PKG12-STD-FM	10' 4" x 6' 6" STANDUP	List \$5,852.00
QL2PKG12-SIT-FM	10' 4" x 6' 6" SITDOWN	List \$5,645.00
QL2PKG11-STD-FM	8' 8" x 6' 6" STANDUP	List \$5,141.00
QL2PKG11-SIT-FM	8' 8" x 6' 6" SITDOWN	List \$4,967.00
QL2PKG10-STD-FM	8' 8" x 5' STANDUP	List \$4,547.00
QL2PKG14-STD-FM	8' 8" x 6' 8" STANDUP	List \$5,191.00
QL2PKG5-STD-FM	7' 2" x 5' 8" STANDUP	List \$3,623.00
QL2PKG9-SIT-FM	8' 8" x 5' SITDOWN	List \$3,489.00
QL2PKG8-STD-FM	8' 10" x 8' 3" STANDUP	List \$5,852.00
QL2PKG8-SIT-FM	8' 10" x 8' 3" SITDOWN	List \$5,706.00
QL2PKG7-STD-FM	7' 2" x 8' 3" STANDUP	List \$5,208.00
QL2PKG7-SIT-FM	7' 2" x 8' 3" SITDOWN	List \$5,068.00
QL2PKG1-SIT-FM	7' 2" x 4' SITDOWN	List \$2,884.00
QL2PKG6-SIT-FM	7' 2" x 6' 7" SITDOWN	List \$4,497.00
QL2PKG9-STD-FM	8' 8" x 5' STANDUP	List \$3,584.00
QL2PKG5-SIT-FM	7' 2" x 5' 8" SITDOWN	List \$3,539.00
QL2PKG4-STD-FM	8' 10" x 6' 8" STANDUP	List \$5,208.00
QL2PKG4-SIT-FM	8' 10" x 6' 8" SITDOWN	List \$5,068.00
QL2PKG3-STD-FM	7' 2" x 6' 6" STANDUP	List \$4,558.00
QL2PKG3-SIT-FM	7' 2" x 6' 6" SITDOWN	List \$4,424.00
QL2PKG2-STD-FM	7' 2" x 4' 10" STANDUP	List \$3,898.00
QL2PKG6-STD-FM	7' 2" x 6' 7" STANDUP	List \$4,609.00

*Prices too low to advertise. Call BSW for the lowest price 1-800-426-8434.



Today's Forecast: Simply Elegant Furniture

Custom-Designed for Radio, Podcasting and More

For over 35 years Forecast Console has designed and produced the highest quality consoles and technical furniture for broadcast/radio production, recording/post production, houses of worship and more. Their ergonomic and innovative furniture solutions make it easy for producers and talent to devote their energies to the broadcast's content without getting bogged down in technical details.

Forecast Console's Podcast line features removable sound panels at every position to combat noise, and because many shows have a video component, the line boasts clean, uncluttered tabletops. Other features include convenience charging, easy mounting for mic arms, and customizable finishes. Forecast furniture comes with a standard lifetime warranty. Contact a BSW GearHead for all your Forecast options.

CR-5-CONSOLE	CR - 5 OP Console	List \$21,802.67*
PODCAST-AH-S	Arrowhead Shaped Podcast Console (Small)	List \$6,790.00
PODCAST-FC-AH-L	Arrowhead Shaped Podcast Console (Large)	List \$9,360.00
PODCAST-FC-CL-L	Clover Leaf Shaped Podcast Console (Large)	List \$5,660.00
PODCAST-FC-CL-MINI	Clover Leaf Shaped Podcast Console (Mini)	List \$3,325.00
PODCAST-FC-FS-S	Fidget Spinner Shaped Podcast Console	List \$5,810.00
PODCAST-FC-GP-L	Triangle Shaped Podcast Console (Large)	List \$5,810.00
PODCAST-FC-GP-MINI	Triangle Shaped Podcast Console (Mini)	List \$2,825.00
PODCAST-FC-SR-S	Stingray Shaped Podcast Console	List \$7,750.00

*Prices too low to advertise. Call BSW for the lowest price 1-800-426-8434.

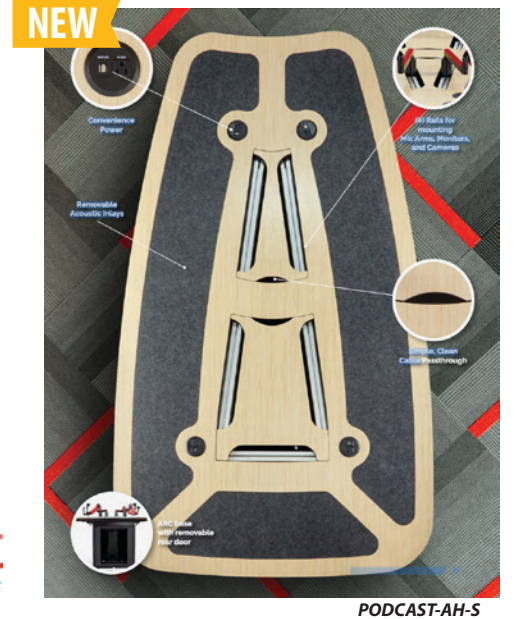

Forecast
INNOVATIVE TECHNICAL FURNITURE

PODCAST-AH-S

For the biggest studio furniture selection, we'll go head-to-head with any of our competitors!

800.426.8434

Justin Warbreck, GearHead
JustinW@bswusa.com



More online!
Scan for full specs.

GRAHAMSTUDIOS

Time-Tested Quality from Graham Studios

1L-RXPC	Radius curve unbalanced U sit down	List \$7,240.00*
1L-RXPC-36	Radius curve unbalanced U w/legs, left-handed stand-up	List \$7,555.00
1R-MOD	Wood trim unbalanced U sit down	List \$10,995.00
1R-MOD-36	Wood trim unbalanced U stand up	List \$11,595.00
1R-RXPC	Radius curve unbalanced U sit down	List \$7,240.00
1R-RXPC-36	Radius curve unbalanced U stand up	List \$9,058.00
3L-MC-36	Custom desk for WEDM Production Studio	List \$10,995.00
3L-RD	Radio desk w/ 2 cabinets, sit down	List \$2,515.00
3L-RD-36	Radio desk w/ 2 cabinets, stand up	List \$2,725.00
3L-RXPC-36	Radius XP curve - 36" stand up	List \$6,595.00
3R-RXPC-36	Radius XP desk - 36" stand up	List \$6,595.00
4L-RXPC-36	Radius curve short U, stand up	List \$6,595.00
4R-RD	Radio desk W/2 Cab. Right-handed, sit-down	List \$2,995.00
5L-RD-36	Radio desk - 36" stand up	List \$2,725.00
5R-RXPC	Radius curve short L sit down	List \$5,770.00
5R-RXPC-36	Radius curve short L stand up	List \$7,318.00
EQ-PDM	Equipment rack pod / Modulux 12RU	List \$1,045.00
EQ-PDR	Equipment rack pod / Radius XP 12RU	List \$681.00

*Prices too low to advertise. Call BSW for the lowest price 1-800-426-8434.

Full HD Recording and Streaming to the Cloud

BSW
EXCLUSIVE

NEW



Your Recording Studio in a Browser

- Compatible with Mac and Windows.
- Records your podcast in HD to the cloud
 - Livestream in HD to Facebook, Youtube, and an RTMP destination simultaneously
 - Invite up to 7 guests. All they need to do is click on a link in their web browser
 - AI based automated camera switching. Saving you a ton of editing time!
 - Download your recordings or share them with a link
 - Do you need audio recording only? No problem, it's available in your AirLink studio as well

AIRLINK-PRO	15 hours of multi-camera FULL HD recording and streaming per month	List \$468.00 *
AIRLINK-LITE	5 hours of multi-camera HD recording and streaming per month	List \$299.00

Cloud based streaming multicamera software, 1-year annual license.

*Prices too low to advertise. Call BSW for the lowest price 1-800-426-8434.

**TRY FOR FREE! VISIT BSWUSA.COM
OR CALL BSW TODAY 1-800-426-8434.**

BSW
CUSTOMER
FAVORITE



NOW with voice activation camera switching



HDV Mixer
Visual Radio made simple

BUNDLE WITH RODECASTER PRO II!

Perfect Video Podcasting Packages

These BSW-Exclusive packages have the tools you need for powerful, audience-grabbing podcasting or other internet broadcasting. You get HDVMixer's innovative HDV-LITE software for recording and live-streaming your video, switching cameras,

adding titles and more, bundled with the RØDE RØDEcaster Pro II integrated audio production studio and your choice of cameras (two Logitech C920 or two OBSBOT Tiny 4K) and accessories.

RCPII-HDVLITE-PKG	RCPII, HDV-LITE and 2 HDV-CAMKITS	List—\$2,795.00*
RCPII-HDVLITE-PKG2	RCPII, HDV-LITE and 2 OBSBOT-TINY4K	List—\$2,835.00
HDV-LITE	3 cam, video podcasting software. <i>Yearly renewal plans starting at \$399</i>	List—\$1,298.70
HDV-ONE	1 cam, video podcasting software. <i>Yearly renewal plans starting at \$399</i>	List—\$599.00
HDV-A	On-air video production automation server license	List—\$3,594.00
HDV-A-PLUS	Premium version with on-screen PTZ camera controller and more	List—\$10,610.46
HDV-1CAMKIT	C920 Camera, table stand, 16ft extension cable	List—\$249.00

*Prices too low to advertise. Call BSW for the lowest price 1-800-426-8434

Pro Broadcast Cameras from Bolin Technology



Gold-Standard Performance at Any Budget

Bolin's newly created Blue-Line PTZ cameras deliver high-end performance at a budget-friendly price. Perfect for lightweight AV systems, the cameras offer high-quality video from Full HD to 4K 60p resolution and standard control protocols essential in ProAV, UC, and light broadcast applications.

B2-210	FHD PTZ, 10X optical zoom	\$595.00
B2-220	FHD PTZ, 20X optical zoom	\$795.00
B7-220	FHD PTZ, up to 1080p60	\$995.00
B6-420	4K60 PTZ, up to 2160p60	\$1,395.00
B9-418	4K30 PTZ, black	\$3,995.00
B9-418W	4K30 PTZ, white	\$3,995.00

Professional-Grade PTZ Cameras

Bolin's flagship Red-Line indoor PTZ cameras offer an enhanced broadcast-quality image, versatile connectivity, and durable construction optimized for broadcast and live production. With their ultra-low latency and low bandwidth, Red-Line cameras are ideal for baseband and AV over IP workflows as well.

R9-230H	Indoor, FHD PTZ	\$3,995.00
R9-418F	Indoor, 4K30 PTZ, black	\$4,995.00
R9-418FW	Indoor, 4K30 PTZ, white	\$4,995.00
R9-420F	Indoor, 4K60 PTZ	\$3,395.00

Divine Dante Video Cameras

Bolin's Dante AV-H PTZ cameras seamlessly integrate into an existing Dante audio ecosystem using Dante Controller Software, and deliver flexible, independent audio and Dante AV video routing across your network.

The Dante AV PTZ camera D412/D220 is a Dante AV Ultra hardware enabled pan, tilt, zoom camera interfacing video and audio in a standard 1 Gbps network. It offers superb video quality with extreme low latency and AV synchronization.

D2-210H	FHD PTZ, 10X optical zoom	\$795.00
D2-220H	FHD PTZ, 20X optical zoom	\$995.00
D6-420H	4K60 PTZ, 20X optical zoom	\$1,695.00
D412	AV-Ultra PTZ, resolution up to 4K60	\$1,995.00
D220	AV-Ultra PTZ, resolution up to 1080p60	\$1,595.00

Accessories:

D20H	AV-Ultra Transceiver(Encoder/Decoder)	\$1,295.00
D20S	AV-Ultra Transceiver(Encoder/Decoder)	\$1,495.00
EG40DH	Decoder	\$1,295.00
EG40F	Decoder	\$1,195.00
BL-BR4K-1	Receiver	\$449.00
BL-PP97	POE power injector	\$495.00
BL-VNS-1	Visca-Over-IP/RS232/422 convertor	\$495.00
B-OSM-12	Optical SFP module transceiver	\$395.00
BLA-10	Audio input/output adaptor cable	\$95.00



Shooting Video? You Need BSW



BMD-HYPERD-PTSHD



BMD-CINECAMPOCHDMFT4K



BMD-HYPERD-RSTEX4KHDR

True Digital Film Cameras and Feature-Packed Video Recorder/Players

Blackmagic Design Cinema Cameras boast wide dynamic ranges for shooting true digital film along with precision mount optics and high quality RAW and ProRes file recording.

- True digital film cameras in compact, handheld size
- Cinematic quality for all your productions
- Wide dynamic ranges for rich detail and brighter highlights without clipping
- HyperDeck Shuttle HD (BMD-HYPERD-PTSHD): desktop live production clip player and master recorder supporting H.264, ProRes and DNx files
- HyperDeck Extreme 4K HDR (BMD-HYPERD-RSTEX4KHDR): records and plays H.265 and ProRes files in all SD, HD and Ultra HD standards up to 2160p60; includes scopes, upgradable cache plus SDI, HDMI and analog video

BMD-HYPERD-PTSHD	\$495.00
BMD-HYPERD-RSTEX4KHDR	\$2,995.00
BMD-CINECAMPOCHDMFT4K	\$1,295.00



More online!
Scan for full specs.

Ultra High Definition Handy Video Recorders

Zoom's Q2n-4K Handy Video Recorder offers brilliant 4K imaging, high-quality audio and a USB interface for easy live streaming and data transfer. The Q8n-4K adds a 4-track audio recorder, two XLR mic/line inputs (with phantom power) and more. Call, email, or visit our website for full info.

Q2N-4K	Handy video recorder	\$199.99
Q8N-4K	With dual mic/line inputs and 4-track audio recorder	\$399.99



LIVESHOT-STUDIO

BSW
CUSTOMER
FAVORITE

On-the-Go Live Video Streaming

Comrex's LiveShot Portable helps deliver high-quality, low-latency live video over a range of IP networks.

- H.264 video codec
- AAC, HE-AAC, and AAC-ELD audio codecs
- Less than 200mS delay for two-way broadcast (depending on network factors)
- Full-duplex cue channel
- CrossLock VPN technology for secure and stable broadcasting
- Highly portable – 3 lbs, camera mounted, runs on phantom battery power
- Works over 3G/4G/5G networks, Wi-Fi, wired broadband IP connections, and more
- Works in conjunction with LiveShot Studio

LIVESHOT-PORTABLE List-\$7,000.00*



Rackmount Video IP Codec

LiveShot Studio is a state-of-the-art codec for high quality video using low network bandwidth.

- H.264 video codec
- AAC, HE-AAC, and AAC-ELD audio codecs
- Less than 200mS delay for two-way broadcast (depending on network factors)
- Full-duplex cue channel
- CrossLock VPN technology for secure and stable broadcasting
- Works over 3G/4G/5G networks, Wi-Fi, wired broadband IP connections, and more
- Works in conjunction with LiveShot Portable OR another LiveShot Studio

LIVESHOT-STUDIO List-\$6,000.00*

*Prices too low to advertise. Call BSW for the lowest price 1-800-426-8434.



LIVESHOT-PORTABLE FRONT



LIVESHOT-PORTABLE BACK



LIVESHOT-HUB



More online!
Scan for full specs.

Use Multiple USB Modems at Once

LiveShot Hub helps LiveShot Portable stream high quality video in challenging 3G-only environments.

- Offers connections for up to four USB devices in challenging 3G-only environments
- Provides additional 3G bandwidth

LIVESHOT-HUB List-\$400.00*



Robust Cellular Modems Designed for Broadcast

The Comrex Connect Modem is a high-powered, industrial strength 4G/LTE modem that is also 3G compatible (not Verizon). It's available in three versions, supporting connections to Verizon, AT&T, and International networks, and is PTCRB and carrier certified to meet all necessary regulations.

- Designed to easily handle the challenges of remote broadcasting
- 4G/LTE modem (also 3G compatible-not Verizon)
- High gain antenna for handling the heavy data load of an IP video broadcast
- Industrial strength, more powerful than commercial USB modems
- Available for Verizon, AT&T, and international carriers
- Unlocked, carrier approved, PTCRB certified

LIVESHOT-CONNECT-INT For international networks List-\$500.00*

LIVESHOT-CONNECT-US For US networks List-\$500.00



The gear you need **AND** what to do with it. For demos, how-to and special feature videos from BSW, visit our YouTube channel.

YOUTUBE.COM/BSWUSAVIDEO



Vivid Studio Warning Lights



Innovative LED Signaling

LITT by Yellowtec is an innovative, high-tech LED signaling device that brings convenience and flexibility to almost any kind of signaling application. It can control up to five color segments (sold separately).

YT9100	Base unit	\$174.84
YT9201	22mm red	\$116.56
YT9202	22mm green	\$116.56
YT9203	22mm yellow	\$116.56
YT9204	22mm white	\$135.36
YT9205	22mm blue	\$135.36
YT9301	33mm red	\$121.26
YT9302	33mm green	\$121.26
YT9303	33mm yellow	\$121.26
YT9304	33mm white	\$140.06
YT9305	33mm blue	\$140.06



BSW
CUSTOMER
FAVORITE

Avoid Surprises - Get a Warning Light

Cool Controller and LED Driver for Studio Signal Lights

The Angry Audio Studio Signal Light Gadget features five LED drivers that light up to five different light segments. The front panel's LEDs correspond to the segment colors; the adjacent switch lets you automatically trigger the lights via rear-panel GPI connections, or trigger each one manually. The Gadget can control all five models of the Studio Signal Light.

- Quad driver for M!KA mic arms equipped with LED tally
- Manually activate each light from the front panel
- Front panel LEDs indicate signal light status
- 5-Pin XLR connectors; built-in power supply with 6-foot power cord

STUDIO-SIGNAL-GADGET	Studio Signal Light Gadget	List—\$349.00	\$331.00
SINGLE-STU-SIGNAL	One segment studio signal light	List—\$109.00	\$103.00
DOUBLE-STU-SIGNAL	Two segment studio signal light	List—\$119.00	\$113.00
TRIPLE-STU-SIGNAL	Three segment studio signal light	List—\$129.00	\$122.00
QUAD-STU-SIGNAL	Four segment studio signal light	List—\$139.00	\$132.00
FIVE-STU-SIGNAL	Five segment studio signal light	List—\$149.00	\$141.00



Classic Look Warning Lights

These eye-catching warning lights from On-Air Light Company boast a classic, vintage look but they're not just a pretty face. They are meticulously crafted with high-quality materials for a long life of service. They are available with red or blue lighting (LED or incandescent) in horizontal or A-frame designs with a variety of voltage options to meet most any need.

- Classic ON-AIR lights
- Brushed aluminum housing with plexiglass window
- Long-life lamp or LED in variety of voltage options
- Easy installation, UL approved

ON-AIR LIGHT - RED:			
RETRO-12V-LED	Retro Light, 12V LED	List \$463.44 *	
RETRO-120V-LED	Retro Light, 120V LED	List \$500.52	
RETRO-120V-INCANDESCENT	Retro Light, 120V Incandescent Bulb	List \$469.62	
ON-AIR LIGHT - BLUE:			
MEGA-12V-LED	Mega, 12V LED	List \$818.61	
SIMPLE-12V-LED	Simple, 12V LED	List \$346.50	
SIMPLE-120V-LED	Simple, 120V LED	List \$388.08	
SIMPLE-120V-INCANDESCENT	Simple, 120V Incandescent Bulb	List \$325.71	
A-FRAME ON-AIR LIGHT - BLUE:			
AFRAME-12V-LED	A-Frame, 12V LED	List \$503.29	
AFRAME-120V-LED	A-Frame, 120V LED	List \$539.67	
AFRAME-120V-INCANDESCENT	A-Frame, 120V Incandescent Bulb	List \$479.04	

*Prices too low to advertise. Call BSW for the lowest price 1-800-426-8434.



Eye-Catching On Air Lights

These Titus Lighting On Air warning lights feature a smoked glass window mounted in a silver frame attached to a solid oak mounting base. The warning only appears when illuminated and is blacked out when not in use. Orientation is either vertical or horizontal. Letters are 1" high.

OALHS	Horizontal orientation	List—\$185.00	\$179.00
OALVS	Vertical orientation	List—\$185.00	\$179.00

Universal On-Air Light Controller

The NotaBotYet ON-AIR 85 easily connects with on-air lights powered by 12 volts. Offering 15 pre-programmed on and flashing patterns, it provides an interface to Axia GPIO, WheatNet Logic, or any other open collector logic or dry relay closures to ground.

NBY-A19A850	Universal 12V On Air light controller	List—\$156.00	\$136.00
--------------------	---------------------------------------	---------------	-----------------

LED Tally Light Controller

The Henry Engineering SUPERLIGHT is a logic/control interface for controlling low voltage studio tally lights. It can directly power 12 volt DC LED tally lights that draw up to 500 mA. Along with a flasher circuit, it offers a DPDT relay output for any low voltage switching, speaker muting or other utility use.

SUPERLIGHT	LED Tally Light Controller	List—\$195.00	\$195.00
-------------------	----------------------------	---------------	-----------------

Easily Control Your M!ka Mic Arm's On-Air Signaling

Yellowtec's hush and hush+ take control of your On-Air signaling, working with any m!ka Mic Arm with an on-air LED. Just simply connect your Mic Arm's XLR-5 connector with hush and go on air. Thanks to various control modes, hush and hush+ fit nearly any setup. Control them via hush Remote, GPI, USB-HID or MIDI.

YT3902	Controller with Mic Preamp	List—\$779.00	\$732.26
YT3903	Controller Base Unit	List—\$448.00	\$421.12

Big Red Warning Lights

The standard warning light used nationwide, the Sandies bright red on black letters will keep your staff informed. Back-lit red letters on black background.

- One- or three-sided lights
- Brilliant red lettering when lit
- Solid Steel Frame
- Mounts on standard single gang box
- Available in AC or DC configurations

340-12	ON AIR light, 12v	\$90.25
340-24	ON AIR light, 24v	\$90.25
343-12	Three-sided On-Air Light, 12v	\$90.25
340-REC-12	RECORDING light, 12v	\$90.25



"Excellent recording in-session light!"



340-110

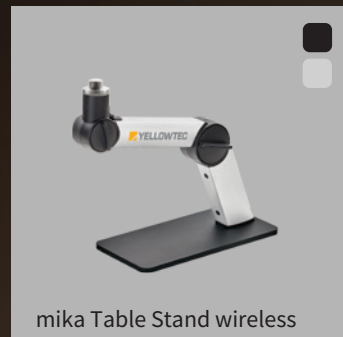

mika Table Stand wireless

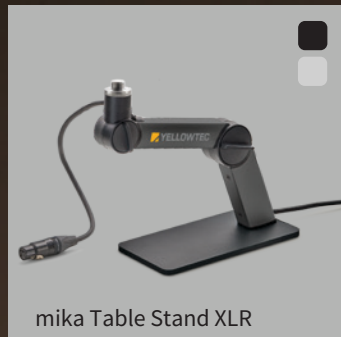

mika Table Stand XLR

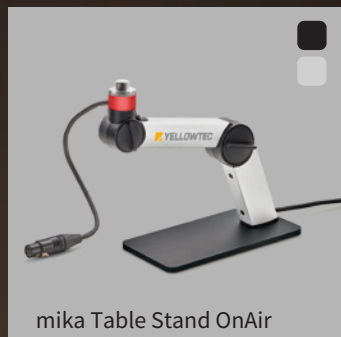

mika Table Stand OnAir

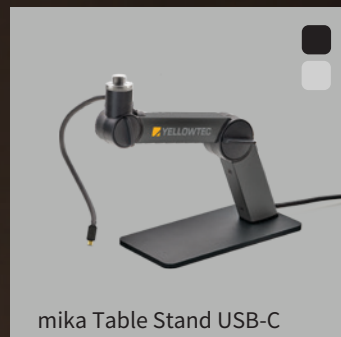

mika Table Stand USB-C

mika Table Stand

The only mic stand with OnAir LED!
Available in multiple versions.



Call BSW for your best
MIKA price! 1-800-426-8434

Easy On-Air Signaling with Yellowtec



Seamless Control for Your m!ka Mic Arm's On-Air Signaling

Yellowtec's hush and hush+ take control of your On-Air signalling, working with any m!ka Mic Arm with an On-Air LED. Just simply connect your Mic Arm's XLR-5 connector with hush and go on air. Thanks to various control modes, hush and hush+ fit nearly any setup. Control them via hush Remote, GPIs, USB-HID or MIDI. Call a BSW GearHead or visit bswusa.com for the full scoop.

YT3900	Hush+ w/ remote control and mic preamp	List—\$879.00	\$826.26
YT3901	Hush w/ remote control	List—\$548.00	\$515.12
YT3902	Hush+ base unit w/ mic preamp	List—\$779.00	\$732.26
YT3903	Hush base unit	List—\$448.00	\$421.12



Ultimate Monitor/Microphone Mounting Packages

A convenient package option, m!ka mounting system Sets give you multiple m!ka elements. Choose the m!ka Sets that fits your needs and combine it with additional m!ka articles if you want to. Every m!ka Set comes with all the items that are needed to affix the included m!ka elements.

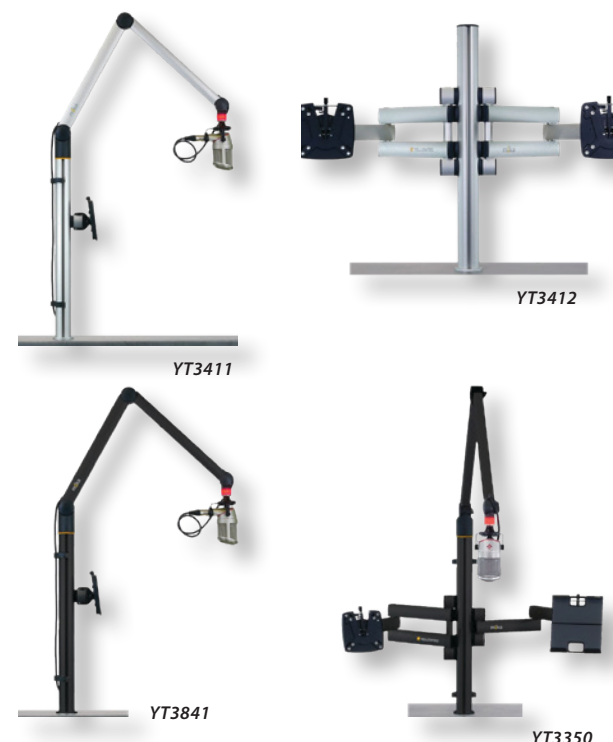

YT3411	Single monitor, single mic set, aluminum	List—\$924.00	\$868.56
YT3412	Dual monitor set, aluminum	List—\$874.00	\$821.56
YT3413	Dual monitor, single mic set, aluminum	List—\$1,389.00	\$1,305.66
YT3414	Triple monitor set, aluminum	List—\$1,078.00	\$1,013.32
YT3415	Triple XL monitor set, aluminum	List—\$1,192.00	\$1,120.48
YT3416	Triple XL monitor, single mic set, aluminum	List—\$1,699.00	\$1,597.06
YT3417	Single monitor, Pad-Dock set, aluminum	List—\$972.00	\$913.68
YT3418	Single monitor, CopyStand set, aluminum	List—\$1,048.00	\$985.12
YT3419	Single monitor, mic, CopyStand set, aluminum	List—\$1,544.00	\$1,451.36
YT3420	Single monitor, mic, Pad-Dock set, aluminum	List—\$1,489.00	\$1,399.66
YT3421	Single TV mic set, aluminum	List—\$699.00	\$657.06
YT3841	Single monitor, single mic set, black	List—\$924.00	\$868.56
YT3842	Dual monitor set, black	List—\$874.00	\$821.56
YT3843	Dual monitor, single mic set, black	List—\$1,389.00	\$1,305.66
YT3844	Triple monitor set, black	List—\$1,078.00	\$1,013.32
YT3845	Triple XL monitor set, black	List—\$1,192.00	\$1,120.48
YT3846	Triple XL monitor, single mic set, black	List—\$1,699.00	\$1,597.06
YT3847	Single monitor, Pad-Dock set, black	List—\$972.00	\$913.68
YT3848	Single monitor, CopyStand set, black	List—\$1,048.00	\$985.12
YT3849	Single monitor, mic, CopyStand set, black	List—\$1,544.00	\$1,451.36
YT3850	Single monitor, mic, Pad-Dock set, black	List—\$1,489.00	\$1,399.66
YT3851	Single TV mic set, black	List—\$699.00	\$657.06



Voice Processing for Every Budget



SMOOTH

Angry Audio Mic Processors Enhance the Classics

The SMOOTH mic processor is designed exclusively for all versions of the iconic Shure SM7 microphone. Its DSP algorithms perfectly enhance the SM7's unique characteristics, and meticulous refinements give you the range you need to tailor the sound of your SM7 to your voice.

Sound Like a VIP

Yellowtec's new VIP Creator is a state-of-the-art one-channel voice processor.

- Single channel digital voice processor
- Sophisticated DSP Functions
- Yellowtec's LEA technology
- High end mic preamp

YT1100

List \$920.00 *

*Prices too low to advertise. Call BSW for the lowest price 1-800-426-8434.



Everybody's Favorite Voice Processor

The dbx 2865 is a full-featured Channel Strip Processor that delivers a studio quality microphone/instrument preamplifier and four processors that can be used independently or in any combination. The sonically pristine mic preamp offers wide-ranging input gain control, switchable +48V phantom power and an 80 Hz high-pass filter to remove low frequency hum.

Great Audio Processing? Symetrix Has an App for It

The Symetrix Jupiter line of audio processors packages powerful DSP into a zero learning curve, turn-key solution drawing its inspiration from the apps paradigm of smartphones.

The three Jupiter hardware offerings differ only in their audio input and output counts. All three use the same software and DSP processes, making your choice of hardware quick and easy. Jupiter 4 offers four inputs and four outputs, Jupiter 8 sports eight inputs and eight outputs, Jupiter 12 boasts 12 inputs and four outputs.

- Turn-key audio processing solution utilizing downloadable apps
- App categories include mixing and routing, public address and distribution, sound reinforcement, and more
- Pre-designed apps greatly reduce installation time



REBEL

The REbel mic processor is engineered exclusively for the popular Electro-Voice RE20, RE27 and RE320 microphones. Its DSP algorithms enhance the distinctive qualities of these EV mics. Carefully designed adjustment bands let you fine tune the sound

SMOOTH List \$899.00 **\$854.00**
REBEL List \$899.00 **\$854.00**



3-Band Dual Voice Processor for BIG Sound

SOUND4 BIG VOICE² is powered with the revolutionary HQ-Sound 192kHz audio processing engine. Its processing structure includes an advanced DeEsser, 3-band noise gate, Pre-EQ 4-band parametric, 3-band Noise Gate, 3-band dynamic processor, Post-EQ 4-band parametric, brick wall limiter and more.

BIGVOICE2-BASE List \$2,725.00 **\$2,316.25** **SOUND4**



▶ See the video at bswusa.com/SM7B-2865-PKG

- Studio quality Mic Preamp / Channel Strip Processor
- Classic dbx compression puts great sound within easy reach
- Frequency tunable De-Esser reduces high frequency distortion

2865 List \$351.93 **\$290.00** **dbx**



JUPITER12

JUPITER12 **\$2,057.00**
JUPITER8 **\$1,830.00**
JUPITER4 **\$1,537.00**



TWO VOICE 1 UNITS SHOWN IN RACK ADAPTER

Fully Loaded Voice Processor

The Wheatstone Voice 1 features peak vocal performance across the entire vocal range, with no undesirable coloration added. It utilizes Super Quiet mic preamps and high quality 24-bit A/D converters. Voice 1 is a WheatNet-IP audio network device similar to its four-channel counterpart, the M4IP-USB, with routable I/O, and logic control.

- Optimized high-frequency EQ, targeted filtering
- High quality 24-bit A/D converters.
- Super Quiet mic preamps
- AES67, remote GUI control

VOICE1 List \$1,500.00 *

*Prices too low to advertise. Call BSW for the lowest price 1-800-426-8434.



Sophisticated, Easy-to-Use Voice Processor

The Wheatstone M-G1 single-channel digital voice processor offers presets, security, networkability and easy-to-set-up parameters. From its PC graphic user interface (GUI), you can control all individual parameters to give each voice talent his or her own sound with just a simple press of a button. Call, email, or visit BSWUSA.com for full specs.

- Control of all audio parameters via intuitive PC GUI
- High-quality, low noise mic preamp
- 44.1, 48 or 96 kHz AES3 output sample rates
- Variable frequency de-esser; voice phase scrambler; adjustable compression, downward expansion

MG-1 List \$1,387.00 *

*Prices too low to advertise. Call BSW for the lowest price 1-800-426-8434.



Smooth On-Air Voice Processing

The Wheatstone M-2 dual-channel voice processor offers a cache of features to make on-air life not only easier, but better-sounding. Set once and forget or create individualized talent settings using custom presets – all recallable via software or automation control. It includes an enhanced 3-band compressor section as well as four bands of EQ.

- High performance mic preamps with 48V phantom power
- 2 completely independent processing channels
- All digital, field proven advanced processing algorithms
- Phase Rotator corrects asymmetrical voice waveforms

M2-WS List \$2,961.00 *

*Prices too low to advertise. Call BSW for the lowest price 1-800-426-8434.



M4: Mic Audio Anywhere In Your Facility

The M4-IPUSB Microphone Processor Blade combines four high-quality microphone preamps, four channels of microphone processing, four independent USB ports, and a WheatNet-IP Blade interface, allowing you to place four microphone inputs anywhere in your WheatNet-IP Intelligent Network (although it also works just fine as a standalone processor). The preamps and processors are accessed and controlled from any point on the network.

- Extremely high performance microphone preamplifiers with 48V phantom power
- Four completely independent processing channels
- Phase Scrambler to correct asymmetrical voice waveforms
- TCP/IP-based remote control from anywhere Via M4-IP
- Use each processor anywhere on your WheatNet-IP Network
- Four independent USB ports

M4-IPUSB List \$5,630.00 *

*Prices too low to advertise. Call BSW for the lowest price 1-800-426-8434.

Time-Tested Electro-Voice RE Mic Series

Ideal for Voice Capture

The Electro-Voice RE320 dynamic cardioid microphone delivers superb detail, dynamic content and natural tonal performance.

- Variable-D pattern proximity control minimizes tonal shifts
- Virtually noiseless performance
- Unique dual-voicing switch selects from two response curves

RE320 List \$337.00 **\$299⁰⁰**



BSW
CUSTOMER
FAVORITE



Legendary Broadcast Microphone

A favorite since the 1960s, the dynamic RE20 gives a slight boost to mid-high frequencies and lets a voice get real close with no bass boominess.

- The classic sound of FM radio voices
- Smooth, natural and controlled sonic character
- Variable-D for minimal proximity effect
- True cardioid polar pattern

RE20 List \$609.00 **\$449⁰⁰**
RE20-BLACK List \$609.00 **\$449⁰⁰**

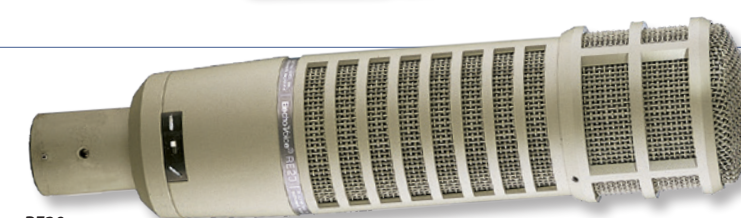

RE20



RE20-BLACK

Revolutionary Broadcast Microphone

The dynamic cardioid RE27N/D boasts a revolutionary neodymium-alloy magnet for increased sensitivity, minimum distortion at high sound pressure levels and an extended frequency response.

- Variable-D reduces proximity effect
- Three switchable filters: one high frequency, two low frequencies
- Internal blast/wind filter reduces P-popping, breath sounds and more

RE27ND List \$700.00 **\$499⁰⁰**

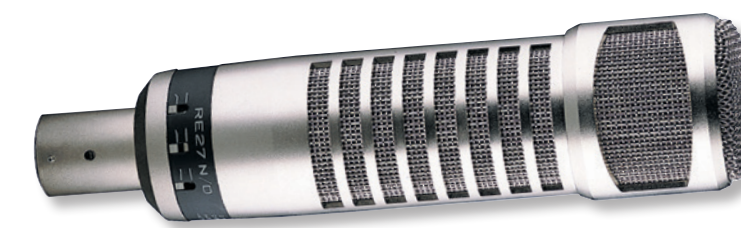

WE HEARD "PAINT IT BLACK"

SO WE DID RE20-BLACK

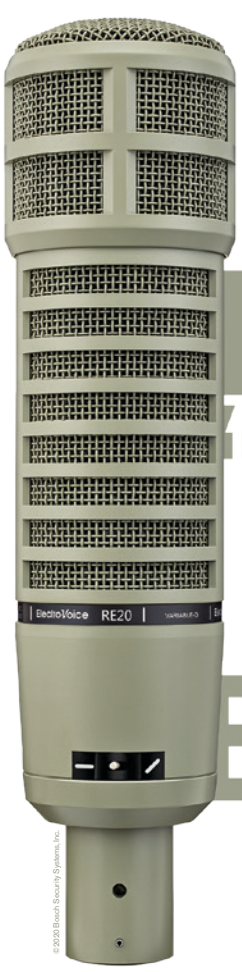

RE320

- Exceptional clarity throughout the vocal range
- Open, vivid and detailed mids and highs
- Two tone-shaping filters
- Integrated pop filter
- Variable-D minimizes proximity effect



RE20 RE20-BLACK

- The classic FM radio voice sound
- Smooth, natural and controlled sound
- Mid-bass tone-shaping switch
- Integrated pop filter
- Variable-D minimizes proximity effect
- Available as RE20 with classic finish, or RE20-BLACK with an elegant, low-reflection dark charcoal finish



RE27N/D

- Full-bodied frequency response
- Crisp and lively high end
- Three tone-shaping filters
- Integrated pop filter
- Variable-D minimizes proximity effect



BSW
CUSTOMER
FAVORITE

RE20-PKG

Save BIG on RE Mic Packages

Get an Electro-Voice 309A shockmount, a custom BSW pop filter and a 20-foot BSW-BMC-20 broadcast mic cable with your favorite RE Series mic. Save up to 54% off list!

RE320-PKG-S List \$759.00 **\$349.99**
RE20-PKG-S List \$858.94 **\$549.00**
RE27ND-PKG-S List \$1,139.45 **\$599.99**
RE20-BLACK-PKG-S List \$858.94 **\$549.00**

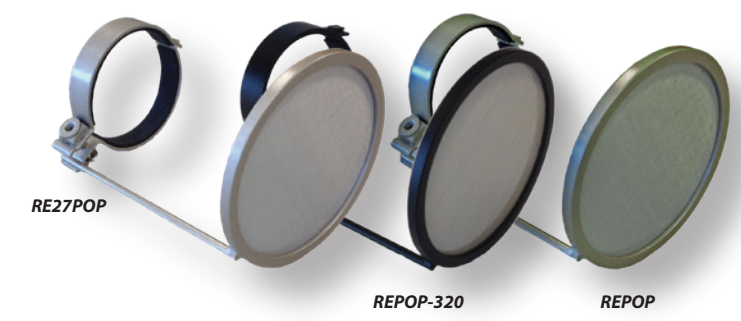

RE27POP

REPOP-320

REPOP

Stop the Pops with the BSW RePop

The BSW RePop's fine mesh metal screen diminishes undesirable P-Popping while keeping the integrity of the hi-end frequency response. The original RePop works with the Electro-Voice RE20, Re27Pop with the EV RE27N/D and RePop-320 with the RE320. They all work great with the Heil PR40, too.

REPOP **\$69.00**
RE27POP **\$69.00**
REPOP-320 **\$69.00**



Call BSW for your best price on Electro-Voice 1-800-426-8434

electrovoice.com | #themicmatters



SHURE



SM7dB | DYNAMIC VOCAL MICROPHONE

BUILT-IN PREAMP. BUILT ON LEGACY.

Introducing the SM7dB Dynamic Vocal Microphone

The SM7dB is a cardioid dynamic microphone with a Shure-designed built-in preamp providing up to +28 dB of low-noise, flat, transparent gain ideal for lower-output interfaces and simplified audio chains.

Features

- + Built-in active preamp providing up to +28dB of extra gain
- + Flat, wide-range frequency response
- + Preamp bypass switch to revert to original SM7B performance
- + Bass roll-off and mid-range emphasis
- + Internal "air suspension" shock isolation
- + Highly effective pop filter eliminates need for any add-on protection
- + Rugged construction and excellent cartridge protection



BSW www.bswusa.com

Call BSW for all your SHURE needs. 1-800-426-8434 • www.BSWUSA.com

Industry-Favorite Broadcast Microphones

Built-In Preamp for Transparent Gain Boost

The SM7dB is a dynamic vocal microphone with built-in preamp providing up to +28 dB of low-noise, flat, transparent gain ideal for almost any interface and simplified audio chains. For podcasters and vocalists, the SM7dB provides improved output and compatibility because of internal phantom powered circuit that is activated by Cloud and optimized by Shure. It features a true bypass gain activation circuit for improved microphone output, selectable gain settings of +18 and +36 dB, smooth, wide, and flat frequency response for speech applications, and bass rolloff and presence boost for tailored response.

SM7DB List \$624.00 \$499.00



Top Choice For Broadcasters

One of the most sought-after mics in the business, the Shure SM7B dynamic microphone offers a smooth, flat, wide-range frequency response and a warm, velvety sound with minimal proximity effect.

- Cardioid polar pattern for maximum rejection and minimum coloration of off-axis sound
- Flat, wide-range frequency response for exceptionally clean and natural reproduction
- Bass rolloff and mid-range emphasis (presence boost) controls with graphic display of response setting
- Powerful rejection of electromagnetic hum, optimized for shielding against broadband interference
- Internal air suspension shock isolation eliminates mechanical noise

SM7B List \$499.00 \$399.00



"Yes, Yes, Yes, and Yes..."



SM7B



More online! Scan for full specs.

Great On-Air Mics from Neumann

Neumann designs some of the finest microphones available for both on-air and recording applications. Both of these mics have what it takes to get the most out of any voice.

- Choice of large diaphragm dynamic or condenser mic
- Integrated pop screen
- Perfect for vocals
- Quick-release headgrille for easy cleaning

BCM104 Condenser \$1,195.00
BCM705 Dynamic \$729.00



BCM705

Great Broadcast Mic with Money Saving Bundle Option

- Rich, natural, condenser-like sound
- Large, 40 mm diaphragm
- Humbucking coil prevents electromagnetic interference
- Hypercardioid polar pattern improves isolation
- Switchable 100 Hz high-pass filter
- Superior off-axis rejection for maximum gain before feedback
- Multistage windscreen for powerful pop filtering
- BP40-PKG Includes: BP40, AT8484 shockmount, Windtech WS1BLK windscreens and BSW-BMC-20 custom broadcast mic cable

BP40 \$349.00
BP40-PKG \$419.00
AT8484 \$99.00

audio-technica



BP40-PKG



More online! Scan for full specs.



BSW
EXCLUSIVE

BSW Exclusive Mic Bundles Save Time and Money



Heil PR40 is the best, ending my quest for "that" sound.
★★★★★
PR40-PKG



Eye-Catching Limited Edition Heil Sound PR 40 Mic Bundles

Heil Sound's PR 40 dynamic broadcast mic offers rich, condenser-like sound with industry-leading rear rejection. It's bundled with a shockmount, custom pop filter and our specially designed broadcast mic cable. For a limited time, get the PR 40 in an eye-catching black and gold finish bundled with essential accessories.

- Package includes shock mount, pop filter, mic cable
- Natural articulation, low distortion, low handling noise
- End fire cardioid pattern, -40 dB of rear rejection
- PR 30 mic also available with same accessories

PR40		\$349.00
PR40B		\$349.00
PR40BG		\$349.00
PR30		\$269.00
PR30B		\$269.00
PR40-PKG	List \$606.95	\$429.00
PR40-BLKGOLD-PKG	List \$555.94	\$459.00
PR30-PKG	List \$458.94	\$379.00



Broadcast Dynamic Microphone

The RØDE Procaster is a professional broadcast quality dynamic microphone, specifically designed to offer no-compromise performance for voice applications in the broadcast environment.

- Balanced, low impedance output
- Internal shock mounting of capsule for low handling noise
- Internal pop-filter to reduce plosives

PROCASTER **\$229.00**



Tightly Focused Studio Mic

The Audix PDX720 high-quality dynamic studio microphone features a hypercardioid polar pattern that's a must-have for any studio professional. With its exceptional versatility, it delivers best in-class audio for a variety of studio applications.

- High-pass filter switch at 120Hz and 155Hz
- Presence boost switch +1.5db and 3db
- Brilliant sound with excellent default gain level
- Frequency response optimized for vocal performance

PDX720 List \$959.00 **\$799.00**



Dedicated Podcast Microphone

Specially designed for podcasting, PodMic delivers a rich, balanced sound to get the most out of any voice. Now available in a cool white finish!

- Broadcast-quality dynamic capsule
- Optimized for speech applications
- Built-in pop filter and internal shock mounting
- Durable, all-metal construction
- Designed to work with RØDEcaster Pro and PSA1 studio arm

PODMIC **\$99.00**
PODMICW **\$99.00**



Multipurpose Compact Dynamic Cardioid Microphone

Full-bodied cardioid pattern and five-position bass control make it an excellent choice for most instruments, as well as group vocals or radio broadcast announcers. One listen and you'll know why it's a classic.

MD421-KOMP List \$329.00 **\$279.00**



Clean Up With Profanity Delays From BSW



NEW

High Performance Profanity Delay Ideal for AoIP

25-Seven's new Program Delay Manager II gives you the exceptional performance you need to handle the demands of today's AoIP world, offering transparent audio quality, program director-friendly features, intuitive operation and more.

2001-00530-000 Program Delay Manager II List \$3,995.00 **\$3,596.00**

- 99 seconds of flexible delay
- PD Alert instantly emails time-stamped audio files whenever Dump is pressed
- Delays IP data, serial streams and GPIO, maintains sync to audio
- Simultaneous control from multiple devices
- Dual Network ports, redundant power, fanless design
- Analog, AES3 digital and Livewire+ connectivity

See the video at bswusa.com/PDM



The Program Delay Manager, Virtualized

PDMX offers all of the same features and functions as PDMII, but in a container-delivered software package that can be deployed on-premises on a COTS server, cloud-hosted services such as AWS, or the Telos Alliance AP-3000 hardware platform.

- PD Alert™ instantly emails time-stamped audio files whenever the Dump button is pressed
- Dump file captures what took place both on-air and off-air
- Seamlessly builds and exits delay, with configurable delay time, build, and dump options
- Delays IP metadata streams and GPIO, maintaining audio sync

3002-00121-000 Program delay software buyout List \$2,750.00 **\$2,475.00**
3002-00121-801 Program delay software, 1 yr sub List \$1,195.00 **\$1,076.00**

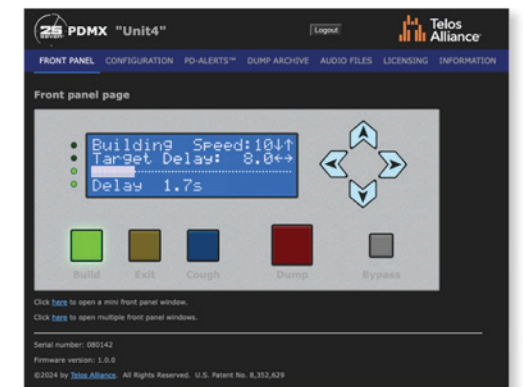

BD600W-PLUS

Profanity delays:
Keeping your live shows
clean, even when your
guests aren't.

800.426.8434

Joey Boothe, GearHead
JoeyB@bswusa.com



80 Seconds of Delay



The Eventide BD600+ delivers up to 80 seconds of high quality revenue and license-protecting delay and features a secondary backup for even more protection.

- 4 - 80 seconds of delay protection
- Secondary backup plays WAV file during delay rebuild
- 24-bit analog XLR and AES/EBU I/O ; USB Remote Control
- BD600E+ Extended Remote adds expanded remote capability for sophisticated automated broadcast chains
- BD600W+ offers convenient WheatNet-IP integration

BD600-PLUS List \$3,999.00*
BD600E-PLUS List \$4,299.00
BD600W-PLUS List \$4,499.00

*Prices too low to advertise. Call BSW for the lowest price 1-800-426-8434.



The Secret to the Tightest On-Air Shows



VP-SURFACE



THE VOXPRO EDIT WHEEL IS NOW AN OPTION ON THE LXE CONSOLE SURFACE. ASK THE BSW GODS FOR PRICING.

The Industry Standard Audio Editor

When you hear a show where all the calls are perfect, with no 'ums' or 'ers' or 'I don't know's, you know that VoxPro is behind it. Wheatstone's VoxPro digital audio editing system lets you record, edit and play back clips in real time on the air in moments. Fast, reliable, and easy-to-learn, the system consists of VoxPro software and a USB hardware control panel (sold separately or available in a money-saving BSW bundle).

VoxPro 7 features new tools for even better performance. For the user, it offers advanced features including Auto-Import, Auto-Record, EZ-Export, Automatic Gain Control, networked file access, customizable folders, and trademark VoiceSlip effect for handling host/caller talk-over. For the engineering staff or system administrator, VoxPro makes networking a snap; its flexibility and versatility allow it to be used in any physical or network configuration.

VoxPro's ClipCleaner toolset includes spectral display, parametric EQ, de-esser, compressor, expander, limiter and noise gate for processing channels independently or jointly. It comes with a standard library of presets for easy setup. It also features FX Macros for creating one-button macros for frequently used effects and other editing operations. FX Macros can be used to create a preset for any effect that can then be assigned to an on-screen button for quick recall.

Contact a BSW GearHead or visit BSWUSA.com for full info on this amazing audio editing system.

- Rich set of playback options
- Editable recordings with several ways to create and use edit points
- Infinite undo/redo capability persists for the lifetime of a file
- Normalization, mute, bleep, reverse, pitch change and time stretch audio effects
- Any number of HotKeys available for immediate one-button playback
- Version 7 features new signal processing toolset, one-button macros and more
- Version 7.1 adds: Producer/Talent multiple tab HotKey pages across entire WheatNet-IP network.
- VoxPro 7.1 is a free upgrade for VoxPro 7 users

VOXPRO7-BUNDLE	Software, controller, license key	List \$4,404.00*
VP-SURFACE	USB controller	List \$2,771.00
VOXPRO-V7S	Software version 7 w/ USB Licence Key 071727	List \$2,436.00

Accessories:

VP-UPG-VP4-7	Upgrade VoxPro Version 4 to version 7	List \$575.00
VP-UPG-VP5-7	Upgrade VoxPro Version 5 to version 7	List \$756.00
VP-UPG-VP6-7	Upgrade VoxPro Version 6 to version 7	List \$441.00

*Prices too low to advertise. Call BSW for the lowest price 1-800-426-8434.



Intuitive Audio Clip Player

Instant Replay 3 is a completely self-contained audio clip player in a box, recording and playing audio in an instant and sporting physical buttons for immediate tactile feedback during audio clip payout. It lets you quickly assign clips to any of the 50 hot-keys on any of the 50 banks and build individual playlists or a stack list from the assigned hot-keys.

- 50 hot-keys; 50 banks
- Full color touchscreen provides real-time information
- Play directly from externally attached USB drives (or copy to the internal system)
- Built in editor allows setting of head and tail points + fade-in / fade-out starting points
- 50 GB of internal solid state memory
- Ethernet networking for file transfer and backup
- Analog balanced audio, plus RCA jacks
- Digital I/O on XLR and BNC

INSTANT-REPLAY-3	List \$3,625.00	\$3,229.00
-------------------------	-----------------	-------------------



Time for a New Clock?

Versatile WallTime Clock

Offering NTP-accurate time with analog and digital clock displays while showing metadata from your automation system and much more, Paravel Systems' WallTime studio clock and notification system conveniently works with a standard computer monitor or TV with no computer required.

WALLTIME	List \$450.00	\$440.00
-----------------	---------------	-----------------



More online! Scan for full specs.



SEE LOTS MORE AT BSWUSA.COM!

Reliable Power From Your UPS

Power controller for ensuring reliable AC power to critical equipment that is powered with an Uninterruptible Power Supply (UPS). BackUPS constantly monitors the output of the UPS, and automatically bypasses the UPS if its output fails or becomes unstable. BackUPS has two AC inputs: LINE and UPS. Line is plugged directly into a local AC socket.

BACKUPS	List \$325.00*
----------------	----------------

*Prices too low to advertise. Call BSW for the lowest price 1-800-426-8434.



Wide Variety of Master Clocks and Timers

ESE's product line covers a wide field, from inexpensive desk clocks to highly accurate GPS Master Clock / Slave systems and time controllers. The ES192A is an affordable 12-hour master clock with hours, minutes and seconds displayed in .56 high amber LED numbers.

- Optional SMPTE, EBU, IRIG-B or IRIG-E output
- ASCII (RS-232C) And ESE time Code Outputs
- Dual 1 PPS Output (20% and 50% Duty Cycles)
- Digital, Video & Analog Slave Clocks Available
- Automatic Daylight Savings Time Correction
- <500 Nano-Second Accuracy

ES101	GPS Master Clock	List \$995.00*
ES110	GPS Based Frequency Generator	List \$1,695.00
ES110P	GPS Based Frequency Generator with Rack Mount	List \$1,750.00
ES126U	Time Code Remote, 1RU	List \$580.00
ES127U	Time Code Remote, 2RU	List \$820.00
ES372U	Console Time Code Display	List \$210.00
ES362UE	100 Minute Up/Down Timer	List \$435.00
ES-520UE	60 Minute Timer	List \$185.00



ES941U	Wall Mount Time Code Display	List \$715.00
ES216P2	Stereo/Dual Mono Audio Level Indicator, Rack	List \$190.00
ES246	Quad 1 x 6 Audio DA (Terminal Block Connectors)	List \$395.00

*Prices too low to advertise. Call BSW for the lowest price 1-800-426-8434.



LED Tally Light Controller

Logic/control interface for controlling low voltage studio tally lights. It can directly power 12 volt DC LED tally lights that draw up to 500 mA. SuperLight includes a flasher circuit, as well as a DPDT relay output that can be used for any low voltage switching, speaker muting, or other utility use.

SUPERLIGHT	\$195.00
-------------------	-----------------



Smooth Multi-Circuit Controller

Henry Engineering's SuperRelay II control interface offers smooth simultaneous switching of multiple circuits, including AC line voltage. It sports six isolated SPDT relay outputs as well as AC and DC tally light outputs that can be set to flash.

SUPERRELAYII	\$99.00
---------------------	----------------



BSW's Big Boom Selection

mika

Specially Designed Booms for On-Air Radio and TV

These Yellowtec Mika booms are perfectly designed for your visually friendly studios to mount either microphones or cameras. Yellowtec's TV booms are low profile with a 26" reach eliminating negative visual impacts in video shots of hosts and guests. The TV booms are designed to mount on Yellowtec vertical poles. The Cam Arms are designed to work with the Cam Studs to mount your cameras with a 31" reach in a studio setting and have several mounting options. Cam Studs can also be mounted on TV booms too. These booms come in models with or without OnAir indicators and are available in natural aluminum or black finishes. They are internally wired with open cable tails for user fitting of connectors or ordered with XLR connectors factory installed.

YT3206	Mic Arm TV black, w/o indicator, open cable end	List \$504.00*
YT3206-XLR	Mic Arm TV black, w/o indicator, XLR-connectors	List \$541.00
YT3207	Mic Arm TV aluminum, w/o indicator, open cable end	List \$504.00
YT3207-XLR	Mic Arm TV aluminum, w/o indicator, XLR-connectors	List \$541.00
YT3208	Mic Arm TV black, OnAir signal, open cable end	List \$599.00
YT3208-XLR	Mic Arm TV black, OnAir signal, XLR-connectors	List \$644.00
YT3209	Mic Arm TV aluminum, OnAir signal, open cable end	List \$599.00
YT3209-XLR	Mic Arm TV aluminum, OnAir signal, XLR connectors	List \$644.00
YT3920	CamArm aluminum, indicator, open cable ends	List \$528.00
YT3920-XLR	CamArm aluminum, indicator, XLR-5 connector	List \$565.00
YT3921	CamArm black, indicator, open cable ends	List \$528.00
YT3921-XLR	CamArm black, indicator, XLR-5 connector	List \$565.00
YT3276	CamStud camera mount aluminum	List \$130.00
YT3277	CamStud camera black	List \$130.00
YT3235	7" Vertical Pole aluminum	List \$61.00
YT3236	7" Vertical Pole black	List \$61.00
POLE-17	Yellowtec Mika pole mounting kit	List \$124.00

*Prices too low to advertise. Call BSW for the lowest price 1-800-426-8434.

mika

Premium Flatscreen Monitor Stands

These stands let you arrange the flat-panel monitors in your studio or workstation efficiently and elegantly. Each of these flat-panel mounts are to be mounted on Yellowtec's own vertical poles and available in natural aluminum or black finishes.

FLEXM	Mika XS Mount aluminum, mounts right next to the pole	List \$204.00*
YT3631	Mika XS Mount black, mounts right next to the pole	List \$204.00
YT3228	Mika SL Mount aluminum, 17" reach	List \$286.00!
YT3628	Mika SL Mount black, 17" reach	List \$286.00
MONARM	Mika Medium Mount aluminum, 19" reach	List \$346.00
YT3630	Mika Medium Mount black, 19" reach	List \$346.00
MONARM-XL	Mika XL Mount aluminum, 27" reach	List \$408.00
YT3629	Mika XL Mount black, 27" reach	List \$408.00
POLE-17	17.5" Vertical Pole aluminum	List \$124.00
YT3640	17.5" Vertical Pole black	List \$124.00
POLE-21	21.5" Vertical Pole aluminum	List \$152.00
YT3643	21.5" Vertical Pole black	List \$152.00
POLE-33	33" Vertical Pole aluminum	List \$199.00
YT3641	33" Vertical Pole black	List \$199.00
PDM-KIT	Yellowtec Mika pole mounting kit	List \$77.00

*Prices too low to advertise. Call BSW for the lowest price 1-800-426-8434.



NEW

mika

Sophisticated Boom Arms

These, Yellowtec Mika mic boom arms sport a classic aluminum or black finish and feature single tube construction with articulated joints to hold mics weighing up to 4.5 lbs. Models are available with and without On-Air indicators and each offer several mounting options. They are internally wired with open cable tails for user fitting of connectors or ordered with XLR connectors factory installed.

YT3105	XS aluminum, OnAir signal, open cable end-21" reach	List \$499.00*
YT3505	XS black, OnAir signal, open cable end-21" reach	List \$499.00
YT3105XLR	XS aluminum, OnAir signal, XLR-connectors-21" reach	List \$544.00
YT3505-XLR	XS black, OnAir signal, XLR-connectors-21" reach	List \$499.00
YT3605	Med black, OnAir signal, open cable end-31" reach	List \$528.00
MIKARM	Med aluminum, w/o indicator, open cable end-31" reach	List \$399.00
YT3601	Med black, w/o indicator, open cable end-31" reach	List \$399.00
YT3205-XLR	Med aluminum, OnAir signal, XLR-connectors-31" reach	List \$573.00
YT3605-XLR	Med black, OnAir signal, XLR-connectors-31" reach	List \$573.00
YT3201-XLR	Med aluminum, w/o indicator, XLR-connectors-31" reach	List \$436.00
YT3601-XLR	Med black, w/o indicator, XLR-connectors-31" reach	List \$436.00
MIKARM-ONAIR-43	XL aluminum, OnAir signal, open cable end-42" reach	List \$639.00
YT3705	XL black, OnAir signal, open cable end-42" reach	List \$639.00
YT3301	XL aluminum, w/o indicator, open cable end-42" reach	List \$539.00
YT3701	XL black, w/o indicator, open cable end-42" reach	List \$539.00
YT3305-XLR	XL aluminum, OnAir signal, XLR-connectors-42" reach	List \$684.00
YT3705-XLR	XL black, OnAir signal, XLR-connectors-42" reach	List \$684.00
YT3301-XLR	XL aluminum, w/o indicator, XLR-connectors-42" reach	List \$576.00
YT3701-XLR	XL black, w/o indicator, XLR-connectors-42" reach	List \$576.00

*Prices too low to advertise. Call BSW for the lowest price 1-800-426-8434.



BSW CUSTOMER FAVORITE

mika

Innovative Desktop Mic Booms

Pleasing to the eye, with internal wiring and coil spring construction hidden from view, Yellowtec's Mika MIKARM Workstation Studio Boom boasts single tube construction with articulated joints to hold mics weighing up to 4.5 lbs.

MIKARM	Mic arm, aluminum finish	List \$399.00 *
MIKARM-ONAIR	Aluminum w/ on-air indicator	List \$528.00
BUSHING	Bushing for mounting arm	List \$115.00
CLAMP	Table clamp	List \$67.00
MAMM	Arm mount for side of pole	List \$157.00
POLE-17	17" vertical pole	List \$124.00
POLE-33	33" vertical pole	List \$199.00
PDM-KIT	Pole mount to desk kit	List \$77.00

Accessories:

YT3211	Bushing for flat mounting to a tabletop XS, Med, XL & Cam Arms with a max thickness of 1.75"	List \$115.00
YT3210	Table Clamp with a mounting range of .70" to 2.9"	List \$67.00
YT3215	Table Through Mount for mounting XS, Med, XL & Cam Arms with a max thickness of .98"	List \$119.00
YT3213	Pole Adapter, aluminum, for mounting XS, Med, XL & Cam Arms to vertical poles	List \$157.00
YT3613	Pole Adapter, black, for mounting XS, Med, XL & Cam Arms to vertical poles	List \$157.00

*Prices too low to advertise. Call BSW for the lowest price 1-800-426-8434.



MIKARM-ONAIR

Cutting-Edge Booms from O.C. White

The Golden Ratio Of MIKa Mic Arms

M-sized mika Microphone Arm is the perfect allrounder in terms of microphone arrangements. It is ideal to shape working desks or interviewing areas where the distance between microphone arm and speaker is not higher than 31" (78.7cm).

MIKARM-USB-AI	Mic arm M with USB-C cable aluminum	List \$409.00 *
MIKARM-USB-BLK	Mic arm M with USB-C cable black	List \$409.00

*Prices too low to advertise. Call BSW for the lowest price 1-800-426-8434



NEW

MIKARM-USB-BLK

New Ultra Low Profile Adjustable Mic Booms

O.C. White's ProBoom Ultima Gen2 ultra low profile adjustable mic booms let your voice talent be both heard and seen. Their innovative design does away with the visual clutter associated with traditional mic booms. Available in a variety of configurations, they support mics weighing up to five pounds. They are not compatible with the first generation of Ultima products.

ULP-10R-13	With 12" fixed horizontal arm, 10" riser	List \$489.00 *
ULP-13	With 12" fixed horizontal arm	List \$369.00
ULP-45-13	With 45° fixed angle arm	List \$419.00
ULP-CLAMP-13	Modular clamp assembly	List \$115.00
ULP-12MA-13	With 12" fixed horizontal arm, 12" riser	List \$589.00
ULP-18MA-13	With 12" fixed horizontal arm, 18" riser	List \$599.00
ULP-2RT-13	With two 12" fixed horizontal arms, 18" riser	List \$995.00
ULP-3R-13	With 12" fixed horizontal arm, 3" riser	List \$499.00
ULP-3RT-13	With three 12" fixed horizontal arms, 18" riser	List \$1,459.00
ULP-4RT-13	With four 12" fixed horizontal arms, 18" riser	List \$1,879.00
ULP-6R-13	With 12" fixed horizontal arm, 6" riser	List \$489.00
ULP-9R-13	With 12" fixed horizontal arm, 9" riser	List \$489.00
ULP-MB-13	With 12" fixed horizontal arm, brushing	List \$419.00

*Prices too low to advertise. Call BSW for the lowest price 1-800-426-8434

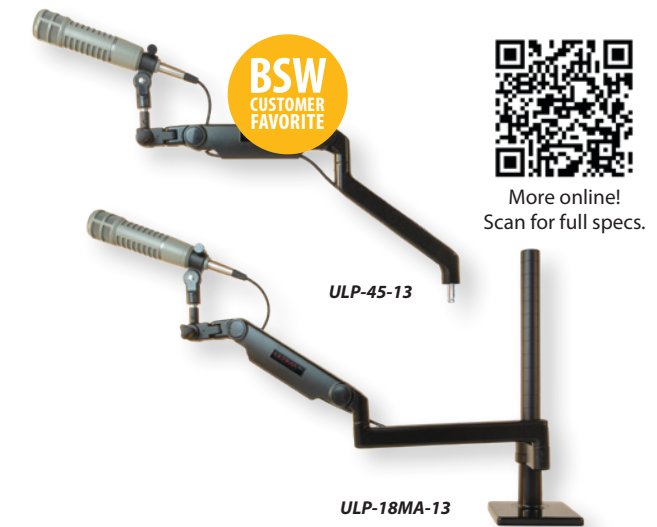

BSW CUSTOMER FAVORITE



More online! Scan for full specs.

ULP-45-13

ULP-18MA-13

Scalable Monitor Systems

O.C. White's ProBoom Ultima Gen2 SMS monitor systems can hold up to six flatscreen monitors simultaneously, as well as offer a common mounting platform for ProBoom Ultima Gen2 mic booms. Assembling quickly and easily, they can be adjusted in seconds as needed. Fit-together joints and fast wire management channels keep your workspace tidy and streamlined. They are not compatible with the first generation of Ultima products.

SMS-1-ULP-13	One monitor arm and 12" fixed horizontal mic arm	List \$975.00 *
SMS-2-ULP-13	Two monitor arms and two 12" fixed horizontal arms	List \$1,329.00
SMS-3-ULP-13	Three monitor arms and three 12" fixed horizontal arms	List \$1,729.00
SMS-4-ULP-13	Four monitor arms and four 12" fixed horizontal arms	List \$2,069.00
SMS-5-ULP-13	Four monitor arms, four 12" fixed horizontal arms, two monitor mounts	List \$2,259.00
SMS-LD-1-ULP-13	One monitor arm and 8" fixed horizontal arm	List \$985.00
SMS-LD-2-ULP-13	Two monitor arms and two 8" fixed horizontal arms	List \$1,329.00
SMS-LD-3-ULP-13	Three monitor arms and three 8" fixed horizontal arms	List \$1,729.00
SMS-LD-4-ULP-13	Four monitor arms and four 8" fixed horizontal arms	List \$2,069.00
SMS-LD-5-ULP-13	Four monitor arms, four 8" fixed horizontal arms, one monitor mount	List \$2,259.00

*Prices too low to advertise. Call BSW for the lowest price 1-800-426-8434



SMS-LD-5-ULP-13

WHITE LITES[®]
O.C. White Co.

Mic & Monitor Arms That Stay Out Of Sight

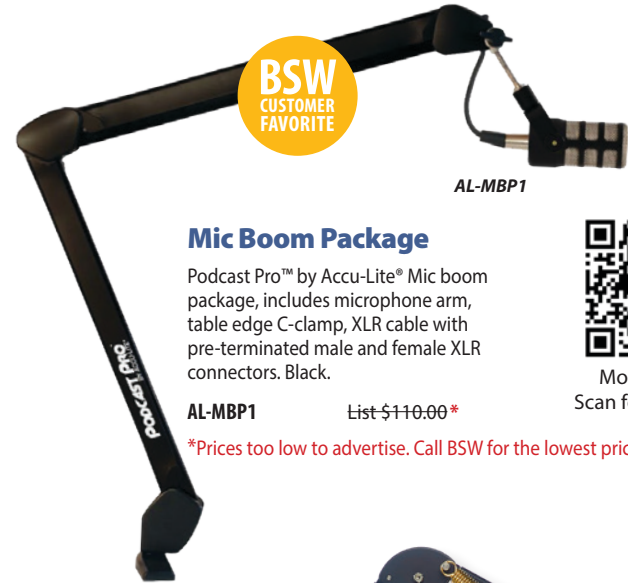

BSW
CUSTOMER FAVORITE

AL-MBP1

Mic Boom Package

Podcast Pro™ by Accu-Lite® Mic boom package, includes microphone arm, table edge C-clamp, XLR cable with pre-terminated male and female XLR connectors. Black.

AL-MBP1 List \$110.00*

*Prices too low to advertise. Call BSW for the lowest price 1-800-426-8434.



More online! Scan for full specs.



ULTIMA ULP, MIC-LITE-ULP

ULTIMA ULP The Elegant & Lowest Profile Mic Arm in a Sleek, Modular, Expandable System

ProBoom Ultima LP Mic Boom with (1) 12in horizontal arm - Machined table bushing included.

ULP-MB-13 0-6 lb rated Ultima Mic Arm List \$419.00*

*Prices too low to advertise. Call BSW for the lowest price 1-800-426-8434.



TALK CAN MAKE THINGS CHEAPER. CALL BSW FOR BEST PRICE! 800.426.8434



BSW
CUSTOMER FAVORITE

Often Copied but Never Duplicated—PROBOOM 61900!

61900BG, MIC-LITE-ULP

ProBoom - The World's Best Professional Studio Mic Arms by O.C. White

- PROBOOM:**
- Solid 1pc. Steel Base Block
 - Music Wire Springs
 - Built in XLR Cradle
 - No Noise On-Air

- 14199-R-B** Elite extended reach mic arm 45" reach with 12" vertical riser in broadcast black List \$255.00*
- 51900BLK** Deluxe mic arm with riser, 29" reach with 12" vertical riser in broadcast black List \$229.00

*Prices too low to advertise. Call BSW for the lowest price 1-800-426-8434.



RØDE

Sturdy Studio Boom Arm

The RØDE PSA1+ is a professional studio arm for mounting microphones to a desk or table, providing full 360 degree rotation and unrestricted mic placement.

PSA1-PLUS List \$149.00 **\$129.00**



HEIL

Versatile Studio Mic Stand

Heil Sound's PL2T boom stand can hold mics weighing up to 2.5 pounds and utilizes a system of internal springs to provide perfect balance and silent, effortless adjustment of its position. A built-in channel for feeding mic cable gives you easy cable maintenance.

PL2T **\$115.00**



BSW
CUSTOMER FAVORITE

GFWMICBCBM2000



BSW
CUSTOMER FAVORITE

GFWMICBCBM3000



GFWMICBCBM4000

Gator Frameworks Desktop Mic Boom Stands

Ideal for podcasting and home broadcasting, these rugged desktop mic boom stands from Gator Frameworks offer impressive reliability and ease of use.

The GFWMICBCBM2000 features a spring-loaded articulating arm holds 2.4 lbs and extends up to 38.6". It rotates a full 360 degrees with minimal noise and sports a knob at the end of the boom for securing a mic at your desired angle.

The GFWMICBCBM3000 also features a spring-loaded articulating arm with a 4.4 lbs capacity and extends up to 32.25". It rotates a full 360 degrees with minimal noise, sports multiple knobs for securing your mic at the desired angle, and boasts a fixed, internally guided 10' XLR cable.

• The GFWMICBCBM4000 is a deluxe desktop stand featuring a 3-color LED On-Air indicator light, spring-loaded articulating arm with a 4.4 lbs capacity and a maximum extension of 32.25". It comes with a removable 10' XLR cable to accommodate most studio mics.

GFWMICBCBM2000	Tripod base with boom	List \$159.99	\$99.99
GFWMICBCBM3000	Round base	List \$209.99	\$129.99
GFWMICBCBM4000	Tripod base with boom, standard clutch	List \$239.99	\$149.99



GFW-MIC-0250



MS300B

Handy Desktop Mic Stands

These desktop mic stands from Gator Frameworks will give you years of reliable performance. Ideal for remote podcast interviews and more.

- GFW-MIC-0250: mini tripod stand offering a convenient collapsible design
- GFW-MIC-0601: larger stand with a weighted 6" round base and twist clutch

GFW-MIC-0250 List \$14.99 **\$8.99**
GFW-MIC-0601 List \$59.99 **\$34.99**



NEW

Ultra-Handy Table Stands

New mlka Table Stands are ideal for positioning your microphone in temporary setups or for guest seats. With the mlka Table Stand you achieve a secure fit and professional balancing of your mic according to its weight. It allows you to customize your mic's position within seconds.

YT3001	Aluminum	\$220.90
YT3001-XLR	With XLR connectors installed	\$255.68
YT3002	With USB-C Cable aluminum	\$220.90
YT3003	Without Cable aluminum	\$220.90
YT3005	"On Air"	\$300.80
YT3005-XLR	"On Air" with XLR connectors installed	\$343.10
YT3401	Black	\$220.90
YT3401-XLR	Black, with XLR connectors installed	\$255.68
YT3402	With USB-C Cable black	\$220.90
YT3403	Without Cable black	\$220.90
YT3405	"On Air"	\$300.80
YT3405-XLR	"On Air" black	\$343.10



More online!
Scan for full specs.

FITS MULTIPLE MICROPHONES!
HEIL PR30, PR40, RODE PODCASTER,
AND PROCASTER

BSW
EXCLUSIVE

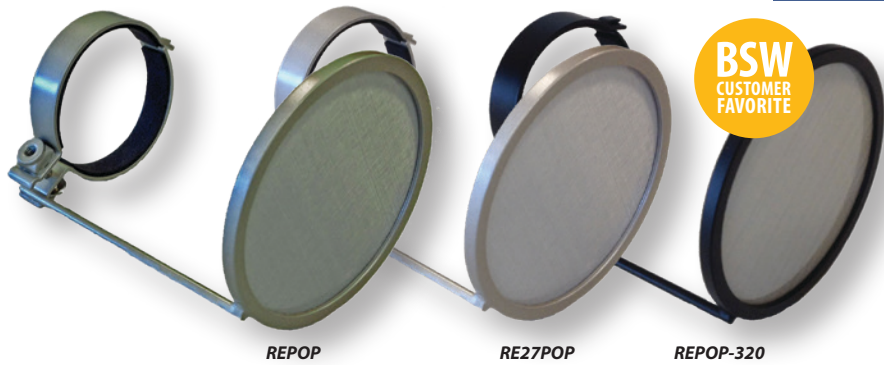

BSW
CUSTOMER
FAVORITE

Pop Filters

Fine mesh metal screen diminishes undesirable P-Popping while keeping the integrity of the hi-end frequency response. Fits any microphone with a 2 in. diameter.

REPOP	for RE20 Mic	\$69.00
RE27POP	for RE27ND/PR40 Mics	\$69.00
REPOP-320	for RE320 Mic	\$69.00



BETTER
BANDS

Strong Bands for Your RE Mic Mount

Better Bands offers wider, stronger bands for the ElectroVoice 309A shock mount for the RE20. These bands means less replacement and savings for you or your station.

- 4-pack of suspension bands for 309A shockmount
- Wider and stronger
- Specially-formulated, heat-resistant silicone
- BN1 is a mounting stud and thumb screw

BB4	List-\$25.00	\$19.99
BN1	List-\$30.00	\$27.99



309A Rubber Bands

4 replacement suspension cords for the Electro-Voice 309A shock mount.

78297PKG	List-\$30.00	\$23.95
-----------------	--------------	----------------



WindTech Microphone Windscreens

WindTech windscreens are high quality, cost-effective and come in a large variety of colors.

- Open-cell foam won't color sound
- Maximum protection from wind-noise and P-popping
- Call or visit our website for full fit and color options

SERIES	DESCRIPTION	DIAMETER (inside)	
WS1BLK	X-large spherical	2"	\$33.75
WS312	Regular spherical, blk	1-3/8"	\$7.50
WS612	Small spherical, blk	1"	\$7.15
WS912	Large spherical, blk	1-5/8"	\$7.99
WS912PACK	5-pack, black	1-5/8"	\$29.95
WS900PACK	5-pack, mixed colors	1-5/8"	\$31.95

RE Series Shock Mount

Electro-Voice's 309A is a suspension shock mount for RE series mics.

309A	\$109.00
-------------	-----------------



Dedicated Windshield

The RØDE WS2 windshield is specially designed to provide extra wind and plosive protection for the RØDE NT1-A studio condenser microphone.

WS2	\$19.99
------------	----------------



Versatile Windshield

The Heil Sound WSPR40 is a foam windshield for Heil PR 30 and PR 40 microphones (it's also compatible with Electro-Voice RE20, RE320 and RE27N/D mics).

WSPR40	\$19.00
---------------	----------------



Great Shotgun Mic Booms

The RØDE Boompole is a precision balanced telescopic boom that extends from 33 inches to 10 feet. With the Boompole, you can mount your microphone securely and swivel it in a range of directions to follow your sound source. The Boompole Pro features a modular design with three sections that you can connect as needed to provide up to 7'2" of reach. The lightweight, low-profile Mini-Boompole extends from 33 inches to six feet, nine inches.

RØDE

BOOMPOLE	33" to 10' extension	\$149.00
MINIBOOMPOLE	33" to 6'9" extension	\$129.00
BOOMPOLE-PRO	Up to 7'2" extension	\$299.00

Super Smooth Automation Solutions

Versatile Broadcast Software

Arrakis NEW-WAVE Windows PC based software is designed specifically for playing audio files from hard disk, Internet streams, FTP stored audio files, MP3 players, smart phones, text to speech and much more. Budget-friendly LA-SUITE boasts the same key features but without the automation engine and scheduling.

- Perfect for Broadcast and Internet Radio
- Live On Air, Automation, and Production
- Simulcast Live, Automate, Stream, and Podcast
- Streaming Radio Server support
- Windows compatible
- On-air radio live assist software, PC

NEWWV-1		List—\$750.00 *
HARMONY-SOUNDCARD	4 Audio Output - 1 Audio input Sound Card	List—\$650.00

*Prices too low to advertise. Call BSW for the lowest price 1-800-426-8434.



BSW
CUSTOMER
FAVORITE



More online!
Scan for full specs.



ARRAKIS SYSTEMS

Premium Automation Package

The Arrakis APEX Plus package features a 16 channel switcher that enables satellite automation and the ability to broadcast professional, college or local ball games. It can receive commands to trigger local breaks, station IDs, and liners. It can also take rain delay and return to game commands for if a game gets rained out. If you don't do satellite automation, ball games or play URL streams, the Hard Disk package is right for you.

- APEX automation On-Air software
- Includes one APEX-Tools license
- Unlimited customer support (phone/email)
- Unlimited software upgrades
- Bridge Switcher, for satellite and ball game automation
- Play network from a URL

APEX-HARD-DISK	List-\$2,699.00*
APEX-PLUS	List-\$4,999.00

*Prices too low to advertise. Call BSW for the lowest price 1-800-426-8434.

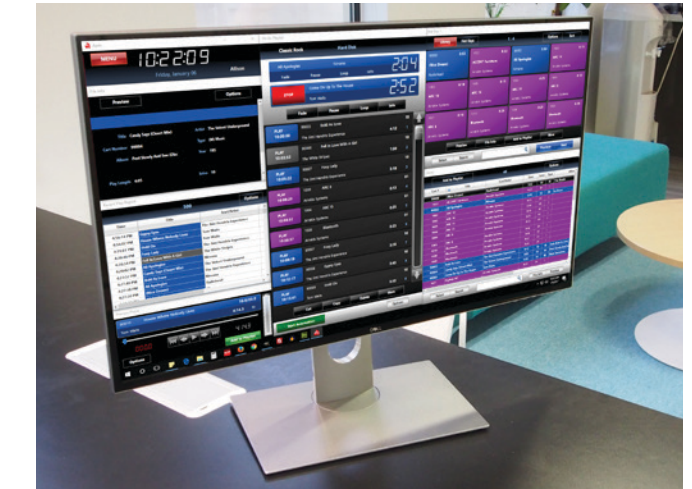

APEX Creator for Efficient Radio and Podcast Production

Arrakis' APEX Creator is a powerful recorder-editor specially designed for Radio and Podcasting audio production applications. It works standalone on a Windows PC, with a third party sound mixer, or integrated with an Arrakis audio console. It can work as an easy-to-use cut and splice editor for assembling audio programs. Its 18 hot key player can play three keys simultaneously with individual level control for each hot key. Hot keys play out to the USB channel on the Arrakis console for mix to the console Program output (or the Default Windows Play codec if not connected to an Arrakis console). The recorder records the Program output from the console or the mic-line input on the PC.

APEX-CREATOR	List—\$200.00*
---------------------	----------------

*Prices too low to advertise. Call BSW for the lowest price 1-800-426-8434.



Boost Your Bottom Line with ENCO Automation



WEBDAD

Automation has never been more powerful

Revolutionize your DAD workflow with WebDAD and AITrack



Breeze through spec ad creation with AI



Call BSW for your best ENCO price
1-800-426-8434 • www.BSWUSA.com

Powerful Instant Audio Playback and Clip Management System

HotShot2 is ENCO's proven audio playback and clip management package for television studio production, master control, remote production, production trucks, and stage events.

HotShot2 provides instant access to audio assets anywhere locally or on the network via a searchable database that supports a virtually unlimited number of audio files and audio types. It conveniently logs what is played for customized reporting. A backlit button box shows actively playing cuts on its 8 banks of 70 buttons.

HotShot2 can play as many as four streams each from four outputs for a total of 16 audio files playing at the same time. Outputs are assignable by column and displayed on the screen.

HotShot2 is available now as a complete package with support for stereo or surround sound applications with optional touch screen monitor.

HotShot2 includes:

- Workstation
- 80-button controller
- ASI 5211 sound card with cable
- Unlimited software upgrades



HOTSHOT2 Button box stereo audio playback package List \$5,295.00*
HOTSHOT2-SURROUND Surround Sound multi-stereo button box package List \$6,295.00

*Prices too low to advertise. Call BSW for the lowest price 1-800-426-8434.



World's Best DAD

DAD provides you with all the tools to make your broadcasts sound better, make running your station easier, and give you unrivaled power and control. With cutting edge integration, capabilities and powerful control automation, DAD keeps your studios running smoothly and efficiently every minute of every day. The highly redundant and flexible architecture allows for infinite scalability and high performance ensuring your specific needs will be met into the future. New advances and improvements are incorporated without long development cycles allowing you to readily embrace new technologies and media. Don't be constrained by the automation system sitting at the core of your operation, let DAD free you up to create radio how you want. DAD will allow you to reduce costs, make the most of your time and grow with you into the future.

DAD ON-AIR:

- Radio automation software license for ON-AIR studios
- Software suite includes: on-air, production, automation, voicetracking, scheduling, content ingest, conversion and transfer tools

DAD PRODUCTION:

- Radio automation software license for production studios
- Software Suite includes: production, voicetracking, scheduling, content ingest, conversion and transfer tools

DAD-ONAIR
DAD-PROD



On-air studio license List \$3,695.00*
 Production studio license List \$2,495.00

*Prices too low to advertise. Call BSW for the lowest price 1-800-426-8434.

BSW
CUSTOMER
FAVORITE

Powerful On-Air and Production Web Streaming Packages

DAD is a complete playout solution scalable from the largest radio broadcast application to small closed circuit systems found in professional sports venues. Running on standard off-the-shelf PC hardware, DAD's complete toolkit allows broadcasters to implement an audio delivery and automation system that precisely meets their needs. It provides a platform for integrating the many sources of content flowing into today's modern broadcast environment including news, traffic, weather, scheduling as well as reconciliation to billing and corporate information systems.

DAD-LP-ONAIR-PKG On-Air package List \$5,495.00*
DAD-LP-PROD-PKG Production package List \$3,995.00

*Prices too low to advertise. Call BSW for the lowest price 1-800-426-8434.





Scan to read about Comrex in use at the 124th US Open.



Deliver Studio-Grade Sound From Anywhere with **ACCESS-NX!**



More online! Scan for full specs.

Loaded Portable IP Audio Codec is THE Work-From-Home Workhorse

Our top-selling codec, the Comrex ACCESS NX portable IP Codec is a work-from-home workhorse designed to take advantage of the latest advances in IP audio transmission. It offers super-fast processors, two mic inputs, phantom power, an internal battery, an EBU 3326/SIP mode for compatibility and lots more. It's compatible with all Comrex IP audio codecs.

ACCESS NX is optimized for running Comrex CrossLock, enabling both powerful error correction and network bonding, while intelligently monitoring and dynamically adjusting network connections in real-time. Call, or visit bswusa.com for full details.

- Network bonding with adaptive management
- 5-inch capacitive touch screen
- Two mic/line switchable XLR inputs
- Stereo line level input and outputs
- Two 1/4" stereo headphone outputs
- Digital mixing and headphone busses
- Input peak limiting
- Selectable producer feed
- Operates on 4G/5G networks, Wi-Fi, Ethernet and POTS (with optional POTS modem)
- LED VU meters
- Internal lithium ion battery



ACCESS-NX	List—\$4,100.00*
ACCESS-NX-MIXER	List—\$1,100.00
BSW-ACCESSNX-CASE	List—\$279.95
ACCESS-CONNECT-MODEM-AV	List—\$475.00

*Prices too low to advertise. Call BSW for the lowest price 1-800-426-8434.



BSW
CUSTOMER
FAVORITE

ACCESS-NX-MIXER
Mixer sold separately

ACCESS-CONNECT-MODEM-AV

ACCESS-NX

Live & Local — National & Worldwide

Do it all with **ACCESS NX**

FEATURES:

- CrossLock VPN for ultra-reliability
- Use any Internet: wired, wifi, cellular, etc
- Switchboard TS for easy NAT traversal
- 2 mic/line inputs & headphone outputs plus an optional 4-channel mixer for a total of 6
- Intuitive 5" capacitive touchscreen for control
- High-quality audio encoding algorithms
- Compatibility with all ACCESS and BRIC-Link models and EBU 3326/SIP for interoperability



BSW
CUSTOMER
FAVORITE

BRIC-Link III for Reliable IP Audio

The Comrex BRIC-Link III offers high-performance audio-to-IP conversion. Leveraging many of the core technical aspects of Comrex's successful remote broadcast ACCESS product line, BRIC-Link III provides for an elegant way of moving linear or compressed audio with very low delay. BRIC-Link III is very simple to use, and can be deployed over a wide range of IP links.

- Enhanced front panel indicators
- Digitized 16-bit audio as well as FLAC, AAC, HE-ACC and Opus algorithms
- Suitable for STLs and other mission-critical functions
- Two units or more required for a complete system
- Switchboard Traversal Server (license sold separately) lets you easily connect and keep track of your codecs on the Internet
- CrossLock provides groundbreaking data channel bonding and redundancy modes for unparalleled broadcast reliability

BRIC-LINK3	List—\$1,900.00*
SWITCHBOARD-TS One license	List—\$100.00

Contact BSW for current pricing 1-800-426-8434.



BSW
EXCLUSIVE

Get a Complete IP Audio System with Exclusive BRIC-Link III Package

Comrex BRIC-Link III is a low-cost, high-performance solution for audio distribution, moving linear or compressed audio over IP networks with ultra-low delay. Easy to use, it's uniquely suited to point-to-point high quality audio links over a variety of data networks, such as ISM band IP radios, T1/E1s, satellite channels, WANs, and LANs. This exclusive package gives you two Comrex BRIC-Link III duplex IP audio codecs bundled with two Middle Atlantic universal rack shelves for one great price.

BRIC-LINK3-PKG	List\$4,150.00*
----------------	-----------------

Contact BSW for current pricing 1-800-426-8434.

Do the Job Right with Comrex



Give Your Studios Full ACCESS

ACCESS NX Rack features completely redesigned hardware, allowing for AES67, AES3 or analog audio I/O. NX Rack can connect to Wi-Fi and 4G modems, and supports a wide range of connection protocols and audio encoders. If you need to run multiple IP codecs at once, ACCESS MultiRack will save you money and space by condensing your rack into one box. Comrex CrossLock technology includes the most advanced network management tool and the option of running multiple networks in bonding or redundancy mode.

- Supports a wide arrange of connection protocols and audio encoders
- Fully AES67 compatible for use with RAVENNA, Dante, WheatNet, or Axia Livewire
- Can connect to Wi-Fi, 4G modems and Ethernet
- Ability to use the Comrex Switchboard
- ACCESS Multi Rack equivalent to five ACCESS codecs in a 1RU chassis

ACCESSNX-RACK	Rackmount stereo IP/POTS codec	List—\$3,200.00*
ACCESS-MULTI-RACK	Rackmount multi-codec	List—\$5,200.00

Contact BSW for current pricing 1-800-426-8434.



COST-EFFECTIVE CHOICE FOR HOME STUDIOS!



Control Multiple Comrex Codecs

Comrex Fleet Commander is a software application for controlling multiple Comrex IP audio codecs simultaneously. With the ability to manage all codecs from one simple window, this easy-to-use tool can save time and increase productivity for busy engineers. Fleet Commander contains all of the functionality of the Web-based Interface, but also comes with a few more features like active metering and the ability to copy peers and profiles between codecs. A Windows application, Fleet Commander can be used to manage every Comrex IP Audio codec in your fleet (depending on CPU and network limitations).

- Simple to use
- Unified interface for multiple codec management
- Compatible with Windows

FLEET-COMMANDER List—\$400.00*

*Prices too low to advertise. Call BSW for the lowest price 1-800-426-8434.

Fact: BSW carries more codecs than the biggest Big Box Store. Don't wander those crowded aisles. Call Paul for it all!

800.426.8434

Paul Schweiger, GearHead
PaulS@bswusa.com



BSW has the Best Selection of Quality Codecs



APT-MULTI-IP-CODEC



Flexible Multi-Channel Audio and MPX Transport

APT's MULTI-CHANNEL IP CODEC transports multiple channels of analog and digital audio or analog MPX/Composite content over IP links and (optionally) with APTmpX, the award-winning algorithm for highest-quality MPX compression. The chassis supports up to 16 audio channels on four AoIP modules within a single rack space unit and even more IP streams with multicast or multiple unicast.

- Dual IP network ports, configurable for management and redundant streaming
- Transports up to two stereo audio channels per module
- Complete Multi-Algorithm Suite as standard
- 192kHz Sampling supports Digital MPX over AES (standard)
- Simplex and duplex operational modes
- Extensive support for 4G/5G connections

- APT SureStream enables broadcast-grade audio over inexpensive IP Links
- Intelligent Networking powered by ScriptEasy and SNMPv2/v3
- Enhanced security with VLAN and built-in firewall
- NTP-based, dynamic content alignment for multi-frequency networks

TF01250-AC-AC	Dual AC-PSU frame	List—\$2,706.00*
STP00034	AoIP module kit audio	List—\$2,289.00
STP00061	AoIP module kit A-MPX	List—\$2,558.00
CD00136	SureStream option	List—\$1,500.00
LC00074	Digital MPX option	List—\$490.00

*Prices too low to advertise. Call BSW for the lowest price 1-800-426-8434.



Broadcast-Grade Stereo Audio IP-Codec

The APT IP CODEC provides a wide range of algorithms, which are standard. It also has dual IP ports and (optional) redundant power supplies. Perfect for STLs and mission-critical applications, this next-generation IP audio codec provides extensive control and monitoring capabilities. NEW: The APT IP Codec is also available for analog MPX/Composite content and supports (optionally) APTmpX, the award-winning algorithm for highest-quality MPX compression.

- Dual IP network ports, configurable for management and redundant streaming
- Extensive support for 4G/5G connections
- 192kHz Sampling supports Digital MPX/Composite over AES (standard)
- APT SureStream enables broadcast-grade audio over inexpensive IP Links
- Intelligent Networking powered by ScriptEasy and SNMPv2/v3
- Enhanced security with VLAN and built-in firewall

- NTP-based, dynamic content alignment for Multi-Frequency Networks
- Optional precision clock module for GPS-based clocking for FM-SFN

APT-IP-CODEC	IP Audio Codec	List—\$2,659.00*
APT-IP-CODEC-MPX	IP audio/MPX codec	List—\$2,790.00
SPP00100-A2	2nd internal AC power supply with mains input for APT IP Codec AC	List—\$444.00
SP02701	GPS Input & SynchoStream Software License for APT IP Codec	List—\$1,770.00
CD00123	SureStream option	List—\$1,500.00
LC00074	Digital MPX option	List—\$490.00

*Prices too low to advertise. Call BSW for the lowest price 1-800-426-8434.

Virtual APT IP Codec for Easy, Low-Cost Program Delivery

WorldCastSystems' Virtual APT IP Codec software supports APT mpX for highest quality MPX compression, SureStream for robust, low cost, and low latency transport over IP, and intelligent ScriptEasy scripting. Using AES67, it can be integrated into virtual studios, removing the need for hardware. High-density encoding/decoding from a single server or in an HA cluster Connects the AES67 studio LAN to any WAN Multiple bidirectional point-to-point or multicast connections.

- Allows high-density encoding/decoding from a single server or in an HA-cluster
- Connects the AES67 Studio LAN to any WAN
- Multiple bidirectional point-to-point, or multicast connections
- Simply and largely scalable
- Easily centralizes and transports a large volume of program signals

Perpetual, single licenses:

SW-VAPT-1-P	Virtual APT IP Codec	List—\$946.00*
SW-VSSR-1-P	Virtual SureStreamer	List—\$946.00
SW-VSE-10-P	Virtual ScriptEasy 10	List—\$1,313.00
SW-VSE-25-P	Virtual ScriptEasy 25	List—\$2,626.00
SW-VSE-50-P	Virtual ScriptEasy 50	List—\$3,938.00

Accessories and Support Contracts:

SU-VAPT	Yearly support for Virtual APT IP Codec	
CD00123	APT SureStream option	List—\$1,500.00
LC00074	APTmpX Option	List—\$490.00

*Prices too low to advertise. Call BSW for the lowest price 1-800-426-8434.

**Call BSW for larger systems offers.



Professional IP Audio Encoders/Decoders

- Simplex audio or Composite/MPX encoder or decoder
- Professional range of algorithms, including aptX
- Bidirectional AUX data transmission
- Extensive support for 4G/5G connections
- Bidirectional AUX data transmission

IP-ENCODER-SILVER	Audio Encoder	List—\$1,380.00 *
IP-DECODER-SILVER	Audio Decoder	List—\$1,380.00
IP-ENCODER-SILVER-MPX	Comp./MPX Encoder	List—\$1,490.00
IP-DECODER-SILVER-MPX	Comp./MPX Decoder	List—\$1,490.00
LC00074	Digital MPX option	List—\$490.00

*Prices too low to advertise. Call BSW for the lowest price 1-800-426-8434.



Back in BLACK



Bridge-IT II

High-end features at a low-end price



Your favorite affordable codec is back with a new look and powerful new features to deliver flexible IP connection solutions. Bridge-IT II is ideal for home studios, simple remotes, STLs, and inter-studio links, plus it includes:

- Support for 2 full-duplex mono connections, or full-duplex stereo, multicasting and multi-unicasting
- Multiple Ethernet and AoIP ports and simple front panel or web-GUI configuration
- Native support for Livewire+, RAVENNA, AES67, ST2110-30, NMOS IS-04 and IS-05 and SIP
- Failover to another connection, HTTP stream, or audio file playback
- Support for wired and cellular wireless connections

Expand the power of your network with Bridge-IT II – the ultimate low cost broadcast codec solution.



www.bswusa.com

Call BSW for your best Tieline price 1-800-426-8434

Versatile, Flexible IP Audio Codecs



New Bridge-IT II Codecs Offer Expanded Flexibility

Tieline's new Bridge-IT II and Bridge-IT XTRA II IP audio codecs deliver high-quality transport for applications such as home studios and simple remote broadcasts, STLs, studio-to-studio links, and multi-unicasting and multicasting. New features offer expanded flexibility for modern networking. Call, email, or visit BSWUSA.com for full specs.

- Native support for AES67, ST2110-30, ST2022-7, Livewire, RAVENNA and more
- Two full-duplex mono connections, or full duplex stereo
- Multiple Ethernet and AoIP ports
- Failover to another connection, HTTP stream, or audio file playback
- Bridge-IT XTRA II includes all algorithms as standard, dual internal power supplies, a front panel stereo headphone output and 4 GPIO in/outs

BRIDGE-IT-II	List \$1,995.00	\$1,896.00
BRIDGE-IT-EXTRA-II	List \$2,995.00	\$2,846.00

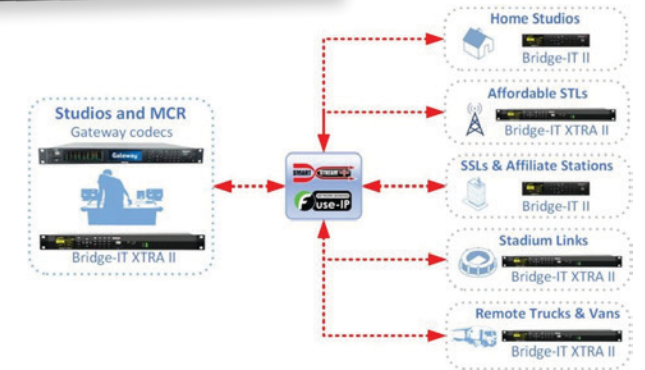

More online! Scan for full specs.



ViA Portable IP Codec

The ViA portable codec from Tieline offers a wealth of IP choices and backup options to make your live remotes incredibly smooth and easy.

- Intuitive, simple to connect LED touch screen
- Supports 3 separate mono connections, stereo, or stereo plus a separate IFB circuit
- Dual Gigabit LAN ports
- Built in Wi-Fi and 2 x USB Cellular Capability
- Fuse-IP bonding of IP interface
- Includes SmartStream PLUS
- Optional ISDN
- Linear audio plus a wide range of algorithms
- Ships with a road case, battery and power supply

VIA	List \$5,445.00	\$5,173.00
TL3G4GDUALVIA-USA	ViA dual LTE aircard for the US market - supports an AT&T and Verizon module	List \$1,635.00 \$1,554.00



Report-IT Enterprise app turns your phone into a codec and recorder.

REPORT-IT-LIVE

More Innovative Tieline Solutions

The handy Report-IT Enterprise app turns your iPhone/Android phone into a 20kHz audio codec and digital recorder. Use cellular or Wi-Fi to stream to a Tieline IP codec in the studio to send live 15kHz audio, or send pre-recorded reports via FTP at 20kHz.

REPORT-IT-LIVE	10 licenses/1 year	List \$399.00	\$380.00
REPORT-IT-LIVE-ADD		List \$59.00	\$57.00
REPORT-IT-LIVE-RENEWAL		List \$59.00	\$57.00
REPORT-IT-LIVE-SERVER		List \$59.00	\$57.00
REPORT-IT-LIVE-SIP		List \$990.00	\$941.00

*Prices too low to advertise. Call BSW for the lowest price 1-800-426-8434.



Cover Your Bases with Barix

BSW
CUSTOMER
FAVORITE



Ultra-Reliable AoIP Streaming

The Barix Exstreamer series features embedded, reliable, IP-enabled audio streaming devices ideal for local and internet-based IP music distribution systems.

- Exstreamer 100, 110: decode IP audio streams and play out the received signal to amplifiers
- Exstreamer 200 decodes IP audio streams and plays out signal via built-in amplifier to 8 Ohm speakers
- Exstreamer 500: multiprotocol IP audio codec with internet radio and VoIP support

EXSTREAMER500	Stereo audio codec	List \$770.00*
EXSTREAMER110	IP audio decoder	List \$320.00
EXSTREAMER100	Decoder w/ display	List \$290.00
EXSTREAMER120	IP codec w/ SD card	List \$320.00
EXSTREAMER205	IP audio decoder w/ S/PDIF, 2X25W output	List \$445.00
EXSTREAMER-STOREANDPLAY	IP audio decoder	List \$280.00
INSTREAMER	IP audio encoder	List \$430.00

*Prices too low to advertise. Call BSW for the lowest price 1-800-426-8434.

BARIX

IP Paging and Intercom Devices

The Barix Annunicom Series features ultra-versatile IP intercom devices that deliver bi-directional transmission of high-quality audio, contact closures and serial data over IP networks. Visit BSWUSA.com for full details.



ANNUNICOM200

ANNUNICOM100	(9.30 VDC 12.24 VAC) USB 2 Watt	List \$425.00 *
ANNUNICOM1000	(24.48 VDC)	List \$995.00
ANNUNICOM155	(24.48 VDC) 5.5 Watt	List \$870.00
ANNUNICOM200	(16.30 VDC, 48 VDC, 16.24 VAC) PoE, USB, 8 Watt	List \$475.00
ANNUNICOM60	(48 VDC), PoE, 5 Watt	List \$340.00
BARIONET-100	IP device server	List \$335.00
BARIXRACKMOUNT	19-inch rackmount shelf	List \$160.00

Accessories:

BARIX6PIN	6-pin terminal block	List \$14.29
BARIXCABLESET	Breakout cable	List \$59.00
BARIXMOUNTINGBRACKET	Mounting bracket	List \$15.00

*Prices too low to advertise. Call BSW for the lowest price 1-800-426-8434.

Background Music Streaming

RetailPlayer offers reliable multi-channel background music and message delivery via the internet.

- Latest generation, robust, cost-effective player
- Cloud or client server based management
- Individual volume and stream selection control

RETAILPLAYER List \$210.00 *

*Prices too low to advertise. Call BSW for the lowest price 1-800-426-8434.



Downloads Audio and Schedules Playback

The Exstreamer Store&Play automatically downloads audio tracks and playlists via IP networks and schedules the playback of the received audio files.

- MP3 decoding
- Stereo line-level output
- USB 2.0 Interface; internal microSD storage, embedded real time clock

EXSTREAMER-STOREANDPLAY List \$280.00 *

*Prices too low to advertise. Call BSW for the lowest price 1-800-426-8434.



Bi-Directional Mono Opus Codec

- Enables remote contribution links with SIP and the Opus open audio format
- Delivers seamless links across VoIP and other IP based communications systems
- Mic/line level input, balanced line level output

MA400-BARIX List \$375.00 *

*Prices too low to advertise.



Stream Live Audio to Mobile Phones

AudioPoint 3.0 can stream live audio via Wi-Fi to the cellphones of up to 250 users as a unicast stream.

- Up to 250 simultaneous streams
- Single channel or multi-channel support
- Web interface for control, status, configuration

AUDIPOINT-30 List \$395.00 *

*Prices too low to advertise.



Live IP Audio Encoder for Streaming

Instreamer ICE encodes analog audio for streaming to an Icecast or Shoutcast internet radio streaming service.

- MP3 and AAC encoding
- Integrated Icecast server feeds up to 50 web radio listeners directly

INSTREAMER-ICE List \$395.00 *

*Prices too low to advertise.



State-of-the-Art STL Systems from BSW

NEW



MPX2

More Innovative Tieline Solutions

Tieline's MPX I and MPX II codecs flexibly and reliably distribute composite FM-MPX signals to transmitter sites. The MPX I smoothly transmits a composite STL signal from a single station with return monitoring. The MPX II can transport up to two discrete composite FM-MPX signals from the studio to transmitters with return monitoring. Both units support analog MPX on BNC, MPX over AES192.

MPX1	Composite FM multiplex codec	List \$3,495.00	\$3,321.00
MPX2	Dual composite FM multiplex codec	List \$4,995.00	\$4,746.00

15-ISH SECONDS CAN SAVE YOU HUNDREDS – CALL BSW FOR BEST PRICE! 800.426.8434

Tieline
The Codec Company



GATEWAY

BSW
CUSTOMER
FAVORITE

Powerful Multi-Channel Codec

Tieline's Gateway can transport multiple channels of mono or stereo audio across any IP network. It streams up to 16 IP audio channels with support for AES67, ST 2110-30, ST 2022-7, RAVENNA, Livewire+, NMOS IS-04 and IS-05, Ember+, AES3 and analog I/O as standard. It's perfect for large-scale audio distribution, studio-to-transmitter links, studio-to-studio links, as well as managing multiple incoming remotes at the studio simultaneously. Gateway "W" versions work seamlessly with the Wheatstone WheatNet-IP intelligent network. An optional Dante card can be installed at purchase to support Dante AoIP networking. The Cloud Codec Controller lets you easily manage an entire fleet of Tieline codecs in real-time from the studio

- Up to 16 mono or 8 stereo bidirectional audio streams
- Natively supports AES67, ST 2110-30, ST 2022-7, RAVENNA, Livewire+, NMOS, Ember+, AES3 and analog I/O options
- Interoperability with WheatNet-IP or Dante networks with optional internal card
- EBU N/ACIP 3326 & 3368 SIP compliant
- Supports HTTP Icecast or Shoutcast streaming.
- Supports multicasting and multi-unicasting

- Program scheduler with automated connect/disconnect
- Multiple layers of backup

GATEWAY-4	4 channels	List \$5,445.00	\$5,173.00
GATEWAY-4D	4-ch, DSP-based with Dante	List \$6,857.00	\$6,515.00
GATEWAY-4W	With WheatNet-IP networkability	List \$6,857.00	\$6,515.00
GATEWAY-8	8 channels	List \$7,625.00	\$7,244.00
GATEWAY-8D	8-ch, DSP-based with Dante	List \$8,710.00	\$8,275.00
GATEWAY-8W	With WheatNet-IP networkability	List \$8,710.00	\$8,275.00
GATEWAY-16	16 channels	List \$14,165.00	\$13,457.00
GATEWAY-16D	16-ch, DSP-based with Dante	List \$15,250.00	\$14,488.00
GATEWAY-16W	With WheatNet-IP networkability	List \$15,250.00	\$14,488.00
GATEWAY-WNET	WheatNet IP Gateway Upgrade	List \$1,680.00	\$1,596.00
GATEWAY-STEREO	Gateway Single Stereo License	List \$2,284.00	\$2,170.00
GATEWAY-2STEREO	Gateway Dual Stereo License	List \$4,246.00	\$4,034.00
GATEWAY-4STEREO	Gateway QUAD Stereo License	List \$8,170.00	\$7,762.00
CLOUD-CONTROL-NETUPGD	Upgrade	List \$399.00	\$380.00
CLOUD-CONTROL-NET	Private network license	List \$699.00	\$665.00

BSW ADVANTAGE CLUB

Sign up today for instant discounts, flexible shipping options, and more!

See p. 4 for details.



Studio Design | Buildouts | Maintenance | A0IP Integration | And More

Get the Gear You Need from BSW,
Then Have INRUSH Set You Up

We have teamed up with INRUSH Broadcast Services, a national leader in media technology integration, to install your new broadcast equipment and seamlessly merge it into your current layout. BSW and INRUSH have got you covered!

Request an install at INRUSH.net

High-Quality Audio and MPX Over IP from 2wcom



NEW

IP-4C

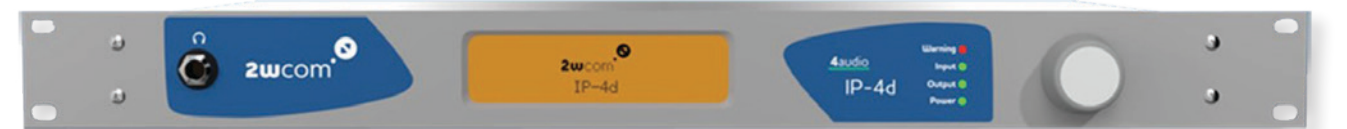

IP-4D



IP-8E-DUAL



MPX-1C



Robust Codecs, Decoders and Encoders

The IP-4c is a point to point or point to multipoint audio codec using IP-based audio network technologies for real-time streaming. Designed for studio-to-studio, studio-to-transmitter links and cross-media tasks, it supports a wide range of protocols for streaming, control and monitoring. Scalability from one to four audio channels using software licenses gives you flexibility in planning your network and reducing your costs. It also features a reliable 90 - 260VAC internal power supply.

The IP-4d is a professional multi-format four-channel audio decoder designed for audio over IP distribution links and supporting a wide range of protocols for streaming, control, and monitoring. Dual Streaming and Pro-MPEG FEC ensure rock-solid IP transmission and Reliable User Datagram Protocol (RUDP) ensures highest packet recovery with minimum bandwidth and low latency. Configuration setup is via an easy-to-use web interface.

The IP-8e is a point to point or point to multipoint real-time streaming IP audio encoder ideal for studio-to-studio, studio-to-transmitter links and cross-media tasks. Its Easy2connect feature provides operators as well as reporters with an easy to use connection establishment (SIP phonebook) when in the field. It also offers DVB-S/S2 multiplexing with program and service tables of up to 8 TS over UDP/Ip tables or of up to 2 TS over ASI interface.

The MPX-1c is a one-channel MPX over IP encoder/decoder giving you real-time distribution of complete FM-MPX (FM composite signal) to connect your signal generation in the studio directly to the transmitter site.

All models are available in dual versions featuring two internal power supplies, and HP versions sporting a slot for two hot plug power supplies.

IP-4C	Audio over IP codec with 90 - 260VAC internal power supply	List-\$2,570.00*
IP-4C-DUAL	Audio over IP codec with two 90 - 260VAC internal power supplies	List-\$2,725.00
IP-4C-HP	Audio over IP codec with slot for two hot plug power supplies	List-\$2,945.00
IP-4D	Audio over IP decoder with 230VAC internal power supply	List-\$2,050.00
IP-4D-DUAL	Audio over IP decoder with two 230VAC internal power supplies	List-\$2,206.00
IP-4D-HP	Audio over IP decoder with slot for two hot plug power supplies	List-\$2,427.00
IP-8E	DVB Audio IP/ASI encoder with 90-260VAC internal power supply	List-\$3,316.00
IP-8E-DUAL	DVB Audio IP/ASI encoder with two 90-260VAC internal power supplies	List-\$3,473.00
IP-8E-HP	DVB Audio IP/ASI encoder with slot for two hot plug power supplies	List-\$3,850.00
MPX-1C	Single-channel MPX/Composite decoder w/ 90-260VAC internal power supply	List-\$2,077.00
MPX-1C-DUAL	Single-channel MPX/Composite decoder w/ 90-260VAC internal power supply	List-\$2,220.00
MPX-1C-HP	Single-channel MPX/Composite decoder w/ slot for two hot plug power supplies	List-\$2,440.00

*Prices too low to advertise. Call BSW for the lowest price 1-800-426-8434.

No one delivers greater performance and network analytics for your IP audio streams



Highly integrated codecs for next-gen, multichannel radio networks and more

Intraplex® IP Link Series

100c · 100e · 100n · 200 · MPXp

Intraplex® Ascent

Up to 32 channels of AES3, Analog, and AES67
Available as software-only solution or as 1RU unit

- Multi-stream encoding lowers channel costs
- Rock-solid, reliable Intraplex connectivity
- Ascent is industry's first solution to support Secure Reliable Transport (SRT) protocol
- Real-time network diagnostics with LiveLook

Ultra-Efficient GatesAir Codecs



More online!
Scan for full specs.



ALSO Intraplex HD Link™

Award-winning digital 950 MHz STL and IP data gateway for reliable multi-path transport

2009 PICK OF THE HIT Radio
2009 BEST OF SHOW Radio
2009 BEST OF SHOW Radio

GatesAir Intraplex IP Link Codecs

Offering a wide range of audio coding options, GatesAir IP Link codecs work great in STLs as well as audio contribution and distribution networks. With its support for IP multicast and multiple unicast streams, one encoder can feed multiple decoders. They boast three independent IP Interfaces for streaming and management and deliver a high level of reliability at budget-friendly prices. Call or visit BSWUSA.com for full details.

- Transparent AES up to 192 kS/s to support composite FM multiplex signal over AES
- Three independent IP interfaces for redundant network operation
- Built-in silence sensor with optional stream switch over
- Automatic backup to audio playout from USB drive or external audio source
- Can encode the same audio source in multiple formats for STL, backup and web streaming
- GatesAir IP-LINK-100 features single bidirectional stereo audio channels
- GatesAir IP-LINK-100P adds advanced signal monitoring capabilities and enables integration with Intraplex SynchroCast systems for multicasting across transmitter networks
- GatesAir IP-LINK-200 features two bidirectional stereo audio channels

IX-IPL-100-AUDPROC	Audio processing license for IX-IPL-100	List—\$650.00 *
IX-IPL-100C	Single bidirectional IP audio codec	List—\$2,133.00
IX-IPL-100MP	IP MPXp codec	List—\$4,152.60
IX-IPL-100P-CSN	Content sync network for IPL-100P	List—\$1,497.50
IX-IPL-200	Two bidirectional stereo audio channels	List—\$4,152.60
IX-IPL-200-AUDPROC	Audio Processing license for IX-IPL-200	List—\$850.00
IX-IPL-200-CSN	Content sync network for IPL-200	List—\$1,497.50
IX-IPL-200-SPL	Dynamic Stream Splicing for IP Link 200	List—\$2,450.00
IX-IPL-100MP-DPKG	Two (2) IPL100MPs and accessories	List—\$10,265.40
IX-IPL200-DPKG	Two (2) IPL200s and accessories	List—\$10,690.92
IX-IPL-LIVELOOK	Intelligent Network Analytics	List—\$495.00
IX-IPL-XPS-MOD	External Redundant Power Supply	List—\$89.10

*Prices too low to advertise. Call BSW for the lowest price 1-800-426-8434.



BSW
Call BSW for your best GATESAIR price
1-800-426-8434 • www.BSWUSA.com



Can't find what
you're looking
for? Call the
GearHeads,
we can help!

800.426.8434

"The ZipOne is everything and MORE than advertised. The audio quality is studio quality and best of all, NO ISDN lines to pay for! I bought two of these and they didn't over promise on these units. They are terrific!"



ZIPONE

IP Codec Handles Toughest Network Conditions

The Telos ZIP ONE 1RU rackmount codec lets you use public IP networks and mobile phone data services for high quality, trouble free audio transmission. Exclusive Agile Connection Technology automatically delivers the best possible audio. This version includes AES/EBU I/O for ultimate flexibility.

USES ACT (AGILE CONNECTION TECHNOLOGY) TO CONTINUOUSLY ADAPT TO NETWORK CONDITIONS

- Audio I/O via AES/EBU, balanced XLR and Axia Livewire IP-Audio interface
- Wide range of high-performance codecs
- Agile Connection Technology for superb transmission

ZIPONE-AES List \$3,295.00 **\$2,966.00**



More online!
Scan for full specs.

CALL BSW FOR THE LOWEST PRICES ON CODECS! 800.426.8434

Telos



Must-Have Multi-Codec Gateway

Telos iPort is a Multi-Codec Gateway designed on an IP backbone that is used by broadcasters worldwide, featuring built-in resilience and reliability even with challenging connections. Worldwide networks use iPort for both distribution and contribution spanning multiple time zones.

IPORT-HIGH-DEN iPort High Density List \$8,395.00 **\$7,556.00**

Virtual Multi-Codec Gateway

Zephyr Connect provides the same features and capabilities as the Telos iPort High Density hardware platform, but in a container-delivered software package that can be installed on-premises on a COTS server or cloud-hosted on services such as AWS. 2 bi-directional codecs are included, expandable to 64 channels per instance in 1-channel increments.

3002-00122-000 Zephyr Connect Base License Buyout List \$2,450.00 **\$2,205.00**
3002-00122-801 Zephyr Connect Base - 1 Year List \$995.00 **\$995.00**



3002-00122-000





HEADS FULL OF KNOWLEDGE



Our GearHeads' heads may wobble and bobble from time to time, but inside those cute, oversized noggins you'll find decades and decades of audio (not to mention video) expertise. If you're looking for the best way to grab your audience, whether you're broadcasting from the studio, on the road or from your home, get in touch with our Gurus. You'll be glad you did. **800.426.8434**

An actual human version of a GearHead will answer your email or phone call.

Not an actual bobble head!

Also not an actual bobble head!



- | | | | | | | | |
|--------------------------------------------------------|-----------------------------------------------|---------------------------------------------|-----------------------------------------------|-------------------------------------------------|--------------------------------------------------|----------------------------------------------|-----------------------------------------------|
| Mike Dorris
INRUSH
GearHead
since 2024 | Jamie Singer
GearHead
since 2004 | John Lynch
GearHead
since 1992 | Bryan Seeley
GearHead
since 2012 | Paul Schweiger
GearHead
since 1997 | Justin Warbreck
GearHead
since 2006 | Joey Boothe
GearHead
since 2021 | Brian Walker
GearHead
since 2023 |
| JamieS@bswusa.com | JohnL@bswusa.com | BryanS@bswusa.com | PaulS@bswusa.com | JustinW@bswusa.com | JoeyB@bswusa.com | BrianW@bswusa.com | |

Out of This World Satellite Receivers



Up to Four Channels of Reliable Reception

2wcom's SAT-4D professional four-channel DVB audio satellite receiver offers uncompromised and reliable reception from one up to four of your audio programs from satellite. The decoder is designed for audio over satellite distribution links, with microsecond accuracy synchronization by GPS latency control (useful for simultaneous signal output of all decoders of a network or for audio description). It supports all known DVB-S/S2 standards and protocols for satellite reception (including 16,32 & 64APSK) and offers symbol rates from 256k to 45 Msym/s.e.

The SAT-4D offers a variety of possible algorithms like MPEG1 Layer 2, MPEG2 Layer 3, most AAC profiles including the new xHE-AAC and AAC-ELDv2, OPUS, Ogg Vorbis, PCM, Enhanced aptX, Dolby Digital plus (on request) and more. Supported by 3 backups, it ensures you'll never go off-air. You can select a range of backup sources such as Icecast/Shoutcast, TS over IP and file playback from the internal memory.

The SAT-4DA is a feature-rich four-channel DVB-S/S2 audio receiver with full analog stereo support. The perfect DVB satellite receiver and decoder for radio networks, it delivers uncompromised and reliable reception of up to four audio programs from satellite.

The SAT-4da is ideal for high-density analog installations, boasting eight XLR outputs to support up to four analog stereo channels. The decoder is designed for audio over satellite distribution links. The combined XLR connectors can be used for digital or analog output (up to four stereo pairs on 8 XLR outputs). Like the SAT-4D, it supports all known DVB-S/S2 standards and protocols for satellite reception (including 16, 32 APSK) and offers symbol rates from 1 up to 45 Msym/s.

Options for SAT-4D and SAT-4DA:

VER63610	Activation of additional audio channel (SAT-4DA)	List—\$455.00*
VER63616	Activation of additional audio channel (SAT-4D)	List—\$130.00
VER63613	Low symbol rate tuner 128 kSym/s (SAT-4D)	List—\$130.00
VER63013	Real-time streaming (SAT-4D)	List—\$195.00
VER63614	Audio-Backup IP input - Icecast/Shoutcast (SAT-4D)	List—\$130.00
VER63615	Audio-Backup File playback (SAT-4D)	List—\$130.00
VER63617	BISS descrambling (SAT-4D)	List—\$260.00
VER63001	Ravenna, AES67, PTP (SAT-4D)	List—\$195.00
VER63012	Livewire+ (SAT-4D, SAT-4DA)	List—\$195.00
VER63003	SFN (single frequency network) (SAT-4D)	List—\$650.00
VER63016	MPX-2ds: SRT/RIST decoder (SAT-4D)	List—\$195.00
VER63024	MPE (Multi Protocol Encapsulation) decoding (SAT-4D)	List—\$260.00
VER63025	TS forwarding over IP (SAT-4D)	List—\$325.00
VER63009	Breakout cable RS232 (SAT-4D, SAT-4DA)	List—\$125.00
VER45851	Hot swap power supply 90 - 230 AC (SAT-4D)	List—\$300.00
VER45852	Hot swap power supply 48VDC (SAT-4D)	List—\$300.00

*Prices too low to advertise. Call BSW for the lowest price 1-800-426-8434.



BSW ADVANTAGE CLUB



BECOME A **MEMBER**

Apply on BSWUSA.com under accounts, email sales@bswusa.com or Call 1-800-426-8434.

Get High Quality, Reliable STL with BSW

BSW
CUSTOMER
FAVORITE



GTX-5

Martí GTX/GRX Series for Superior STL

The Martí GTX/GRX Series transmitters and receivers deliver a frequency-agile Studio to Transmitter Link (STL) with a wide frequency range from VHF to SHF. Both transmitters and receivers offer full digital readout with an intuitive front panel jog wheel and provide extensive RS232-based programmability and monitoring.

Transmitters and receivers come in three configurations: "M" models offer MPX, Mono, and Stereo inputs, "S" models add a stereo encoder, and "AES" models give you that plus an AES/EBU digital audio interface.

They are available in most standard STL frequency bands from 215 MHz to 2.6 GHz (frequency agile within each band), and in power levels up to 15 watts. Call, email or visit BSWUSA.com for more information and specs.

- Compact, direct modulated low noise synthesized, oscillator, with 10 or 25 kHz programming step
- External in-field programmability of frequency and power, without any special instruments over a broad range
- Simple and modular internal construction

GTX-M	List \$3,267.00 *
GTX-S	List \$3,500.00
GRX-M	List \$3,138.00
GRX-S	List \$3,501.00
GTX-AES	List \$4,111.00

*Prices too low to advertise. Call BSW for the lowest price 1-800-426-8434.



More online!
Scan for full specs.

MARTI

Frequency Agile STL System

The Armstrong XLink microprocessor-controlled transmitter/receiver system is frequency agile with heightened sensitivity and impressive selectivity. Virtually instant frequency changes make the XLink the perfect main and back-up STL system.

- 3 SCA, 1 MUX and 1 Mono inputs
- Front panel LCD display for easy control and monitoring of system parameters
- Remote control ready
- Seamlessly interfaces with Armstrong's DX Series of Digital encoders and decoders

XLINK	List \$6,900.00*
XLINKR	List \$3,300.00

*Prices too low to advertise. Call BSW for the lowest price 1-800-426-8434.



Powerful IP Audio Transport Interface

- Works as a translator between high-quality studio networks and low-bandwidth STL connectivity options such as IP wireless radios
- Interfaces directly to an IP wireless radio or commercial leased line for point-to-point connectivity between locations
- AES67 compatible; WheatNet-IP compatible
- Two AES and two analog audio inputs; four programmable logic ports

EDGE	List \$4,202.00 *
-------------	-------------------

*Prices too low to advertise. Call BSW for the lowest price 1-800-426-8434.

When You Think STL, Think BSW

BSW
CUSTOMER
FAVORITE



SL9003QHP-4S



Crystal-Clear, Seamless STL

Moseley Starlink SL9003QHP is an open-architecture, all-digital, HD Radio ready, multi-channel linear audio STL. A fully transparent link in your air chain, it lets the clarity of your audio shine through. AES/EBU I/O combine with a built-in variable rate converter to offer seamless, compression-free connectivity.

SL9003QHP-2S	One 44.1 kHz stereo pair @16 QAM	List \$15,900.00*
SL9003QHP-2SLAN	One 44.1 kHz stereo pair w/ RS-232	List \$17,450.00
SL9003QHP-4S	Two 32 kHz stereo pairs @ 32 QAM	List \$18,450.00
SL9003QHP-4SLAN	Two 32 kHz stereo pairs w/ RS-232	List \$19,950.00
SL9003QHP-8SLAN	8-channel digital STL system w/ IP	List \$21,450.00
SL9003QHP-LAN	Digital STL system, IP only	List \$14,900.00
SL9003QHP-RT	STL repeater with no decode channels	List \$8,500.00
SL9003QHP-RT2	STL repeater with 2 decode channels	List \$10,000.00

SL9003QHP-RT4	STL repeater with 4 decode channels	List \$11,500.00
SL9003QHP-RT8	STL repeater with 8 decode channels	List \$12,500.00
SL9003QHP-TX2	2-channel digital STL transmitter	List \$9,000.00
SL9003QHP-TX4	4-channel digital STL transmitter	List \$10,600.00
SL9003QHP-TX8LAN	8-channel digital STL transmitter w/ IP	List \$12,500.00
SL9003QHP-RX2	2-channel digital STL receiver	List \$7,500.00
SL9003QHP-RX4	4-channel digital STL receiver	List \$8,650.00
SL9003QHP-RX8LAN	8-channel digital STL receiver	List \$10,000.00
STARLINKSL9003T1-2X0	Simplex 2-channel T1/E1/STL	List \$7,500.00
STARLINKSL9003T1-2X2	Full duplex 2-channel T1/E1/STL	List \$10,500.00
STARLINKSL9003T1-2X2LAN	Full duplex 2-channel w/ LAN	List \$12,900.00

*Prices too low to advertise. Call BSW for the lowest price 1-800-426-8434.



XLINK



BSW
CUSTOMER
FAVORITE



Flexible STL Systems from GatesAir

GatesAir's Intraplex line offers a wide range of robust, reliable Studio-to-Transmitter Links that are ideal for audio contribution/distribution networks of any size and architecture.

IX-STLHD:

- STL system specifically designed for IBOC conversion for HD Radio
- Includes two T1 multiplexers and linear stereo audio encode and decode modules

IX-STLHDPLUS:

- IBOC conversion for HD Radio with enhanced apt-X audio compression
- Includes two T1 multiplexers and linear stereo audio encode and decode modules

IX-HDL950-IP:

- HD Link STL system with transmitter unit and receiver unit, configured for IP and aux audio transport only

IX-HDL-PLUS-IP:

- HD Link STL system with transmitter unit and receiver unit, configured for IP and aux audio transport only

IX-HDL950T-IP:

- HD Link Transmitter unit. Configured for IP and aux audio transport only

IX-HDL-950-MAC:

- Harris Intraplex Main/Alt Controller for HD Link 950 MHz systems. Allows hot-standby redundancy of two HD Link transmitters with automatic switching based on main unit failure or user command. Includes control cables to connect to two HD Link transmitters. RF cables sold separately

XLINKR	List \$13,872.00*	IX-HDL-PLUS-IP	List \$16,459.20*
IX-STLHDPLUS	List \$12,930.00	IX-HDL950T-IP	List \$9,533.16
IX-HDL950-IP	List \$16,459.20	IX-HDL-950-MAC	List \$1,790.42

*Prices too low to advertise. Call BSW for the lowest price 1-800-426-8434.



AXON & NEURO

Smart I/O Modules for Smaller Sites & Applications



AXON 8D

8 Digital Input Interface



AXON 8A

8 Analog Input Interface



AXON 5R

5 Relay Output Interface

Combine up to 5 I/O Cards to build a Smart Telemetry Unit with 55 Configuration Possibilities

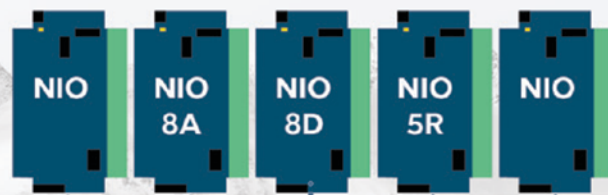

- The HTML 5 Web GUI Allows Easy Configuration & Status List View
- Send Alarms via Email or SNMP TRAPs to an SNMP Manager
- Complete SNMP v1/v2c/v3 Agent to work with most NMS Systems
- Build Onboard Automation with Jobs, Schedulers & Math Functions
- Use Remote Commands to Control Relays on any Other Davicom Products

Intelligent Site Management is a No-Brainer



More online!
Scan for full specs.

Intelligent, Flexible Cortex Systems

Davicom's new generation of intelligent site management systems meet the most stringent requirements of the broadcast industry. These best-in-class, stand-alone monitoring and control units interface easily with virtually any type of remote site equipment and sensors, ensuring maximum flexibility and expandability.

Cortex units can make decisions based on Virtual Logic Gates. Using the readings from the sensors they are connected to, they can automatically control a broad range of equipment at the remote site in multiple ways.

Cortex 360 systems are loaded with features large operations need for comprehensive site management. Cortex 320 systems are optimized to give small market and noncommercial stations all the core benefits of Cortex.

Call, email, or visit BSWUSA.com for full info and specs on all of Davicom's powerful, easy-to-operate Cortex systems.

CORTEX-320-1	Expandable RTU, 1 RU height, half-width included	List—\$3,875.00*
CORTEX-320-1P	Cortex-320 Package	List—\$4,462.00
CORTEX-360-1	Expandable Main RTU SNMP, Ethernet, Dual Power Supply	List—\$6,422.00
CORTEX-360-1P	Cortex-360 Package	List—\$7,634.00
MEXM-1	Expansion Modules	List—\$3,096.00
MEXM-2	Expansion Modules	List—\$3,096.00
DVLD-1	Lightning Detector	List—\$1,296.00
DVLC-1	Lightning Strike Counter	List—\$2,237.00
DTPI	Temperature Probe Interface	List—\$702.00
DAVNET1-10	Alarm Management Software	List—\$4,811.00
NEURO	I/O Telemetry Unit	List—\$945.00
NIO-8A	8-Analog Input Card for NEURO	List—\$425.00
NIO-8D	8-Digital Input Card for NEURO	List—\$295.00
NIO-5R	5-Relay Output Card for NEURO	List—\$355.00

*Prices too low to advertise. Call BSW for the lowest price 1-800-426-8434.

Modular Input/Output Solutions for Superior Control

The NIO-5R adds 5 Form-C Relays that can be used to control other on-site equipment. Relays can be pulsed or latched and also controlled by multiple sources. Maximum of 2 NIO-5R in a NEURO, with mix of 8A or 8D in 3 other slots.

The NIO-8A adds 8 flexible analog inputs that are bipolar & differential. They can accept signals from various sensors thanks to their numerous input ranges, starting at ±0.5 V all the way up to 40 V and including the 4-20 mA industrial sensor standard. You can add up to 5 NIO-8A in a NEURO.

The NIO-8D adds 8 digital inputs that are available for reading logic levels or wet/dry relay contacts, with programmable active high or active low settings. You can add up to 5 NIO-8D in a NEURO.

NIO-5R	5 Relay Output Card	List—\$355.00*
NIO-8A	8 Analog Input Card	List—\$425.00
NIO-8D	8 Digital Input Card	List—\$295.00

*Prices too low to advertise. Call BSW for the lowest price 1-800-426-8434.

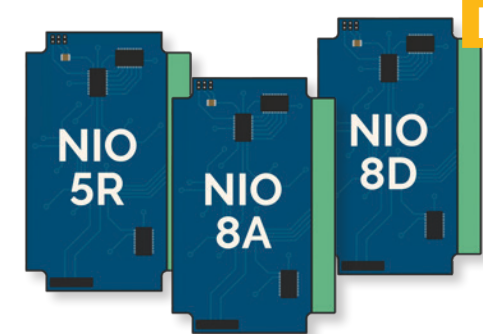

Smart Telemetry Solution

Davicom's intelligent AXON line is specifically designed for smaller remote telemetry applications. Available in three configurations (analog, digital and relay) they offer autonomous devices for alarm, monitoring and automation functionalities, while also implementing distributed intelligence at each location. Thanks to their SNMP agents, these units are the perfect remote telemetry companions to report to any SNMP Manager, including the Davicom's Cortex Series. Please note that these units require an 8-30 VDC Power Supply @ 110-200mA (sold separately).

The AXON-8A's flexible analog inputs are bipolar and differential. They can accept signals from various sensors thanks to their numerous input ranges.

The AXON-8D's inputs are available for reading logic levels or wet/dry relay contacts, with programmable active high or active low settings.

The AXON-5R comes with 5 Form-C Relays that can be used to control other on-site equipment. Relays can be pulsed or latched and also controlled by multiple sources.

AXON-8A	Eight-input analog interface	List—\$896.00*
AXON-8D	Eight-input digital interface	List—\$770.00
AXON-5R	Five relay output interface	List—\$806.00

*Prices too low to advertise. Call BSW for the lowest price 1-800-426-8434.





BSW CUSTOMER FAVORITE

Affordable Remote Site Control

Broadcast Tools' WVRC-8 Plus is a cost-effective, 1RU solution for dial-up recordable voice response and web-enabled site control and monitoring via a web browser, smartphone, or SNMP. You can also program it for dial-up operation via the web interface. You can configure each analog, status, silence sensor, temperature sensor and power failure input to dial-out and/or email up to eight individual phone numbers/email addresses, allowing different input alarms to be routed to different call-out numbers and/or email recipients.

- NTP time base and/or battery-backed real time clock/calendar
- Four virtual metering channels
- 1/8" temperature probe port
- Internal temperature monitor
- Stereo Silence Sensor monitoring with remote telco monitoring
- Allows voice alarms when internet connection or DNS is lost
- Front panel microphone for remote aural site monitoring via phone
- Simple telco hybrid with send and caller balanced audio I/O
- Event-driven and time-based automatic command capabilities

WVRC8PLUS	8 channels	List—\$2,069.00	\$1,965.55
WVRC4PLUS	4 channels	List—\$999.00	\$949.05



SITESENTINEL16G2

Dependable Site Monitoring Systems

Broadcast Tools' Site Sentinel 16 G2 is a full-featured, web-enabled 16-channel remote control featuring a desktop/mobile browser compatible web interface, 16 metering inputs, four virtual metering channels, 16 optically-isolated status (logic) inputs, 33 programmable SPDT relays, four temperature probe inputs, one internal temperature sensor, stereo silence sensor, and power failure input. It includes built-in support for email alarms and SNMP. The Site Sentinel 4 gives you an Ethernet port, four channels of metering inputs, optically-isolated status inputs, normally open dry contact relays, power failure input and a stereo silence sensor input.

SITESENTINEL16-G2	16-channel system	List—\$1,719.00
SITESENTINEL4	4-channel system	List—\$588.05



Easy To Use Serial Remote Control Computer Interface

The SRC-16 + G2 is a computer GPIO interface for the real world. Connecting through RS-232 serial or TCP/UDP Ethernet, it can notify your PC software program if any of 16 optically isolated inputs have been opened or closed, and allows your software to control 16 relay outputs. You can control it via short "burst" type ASCII or binary hex commands from your PC (computer mode). Two SRC-16 + G2's can be used to bi-directionally transport contact closures in pair mode. You can also configure user-defined strings for the input and outputs. Half-rack chassis. Optional RA-1 rack shelf.

SRC16-PLUS	List—\$679.00	\$645.05
-------------------	---------------	-----------------

Accessories:

RA-1	Rackmount shelf	\$103.55
-------------	-----------------	-----------------



Ethernet-Based Remote Control

The I/O Sentinel 4 G2 is a robust, full-featured Ethernet based data acquisition and remote-control device with four optically isolated status (logic) inputs and four programmable relays. You can control and monitor it locally and/or remotely over any IP network, including private networks, industrial control networks and the internet.

IOSENTINEL4-G2	List—\$319.00	\$303.05
-----------------------	---------------	-----------------



ADMS44.22-G2



SS6.1MLR-BNC

Must-Have Matrix and BNC Switchers

The ADMS 44.22 G2 provides matrix audio switching of 4 RJ45 analog inputs, 4 XLR AES inputs, 2 RJ45 analog outputs, and 2 XLR AES outputs. It sports RJ45 audio jacks for analog I/O connections, XLR jacks for digital I/O connections, and plug-in euroblock screw terminal connectors for remote control. The ACS 8.4 G2 delivers matrix audio switching of 8 stereo inputs to 4 stereo outputs. It boasts RJ45 audio jacks for I/O connections and plug-in euroblock screw terminal connectors for expansion and remote control. The SS 6.1 MLR/BNC is a 6x1 BNC switcher designed for N+1 installations and other applications where MPX baseband, AES-3id, or other unbalanced signal switching is necessary. It offers control via front panel controls and/or remotely with simple opto-isolated contact closure inputs and dry contact status relay outputs.

ADMS44.22-G2	List—\$2,369.00 *	
ACS8.4-G2	List—\$1,849.00	
SS6.1MLR-BNC	List—\$679.00	\$645.05

*Prices too low to advertise. Call BSW for the lowest price 1-800-426-8434.

You're in Control with BURK and BSW



More online! Scan for full specs.

BURK TECHNOLOGY



BSW CUSTOMER FAVORITE

Superior Site Control

The Burk ARC Plus Touch combines the features of the award winning ARC Plus with the intuitive navigation of a touch screen for smooth, comprehensive IP-based remote control. It offers easy operator access via front panel, web, PC software, smartphone or telephone, as well as email alerts and selective alarm reporting for efficient fault resolution. Ready for expansion, it scales to 256 metering and status channels, 256 relay pairs and 512 virtual channels.

- TCP/IP-based platform; built-in web interface
- Scales to more than 1,000 sites
- Advanced front-panel control
- Onboard automatic routines
- Email alerts for alarm conditions; selective alarm notifications
- Touch screen (ARC Plus Touch)

ARC-PLUS-TOUCH	IP-based transmitter remote control	List—\$3,785.00*
RSI	Recordable speech interface	List—\$1,155.00
JETFLOWCHARTS	Jet Active Flowcharts	List—\$345.00

*Prices too low to advertise. Call BSW for the lowest price 1-800-426-8434.



Terrific Transmitter Site Monitoring

Keep your transmitter running reliably by monitoring the environment and alerting staff to potentially harmful conditions. The Burk Plus-X EM monitors temperature, humidity, flood/leak, and many other conditions including sound, light and security. Email, SMS and SNMP notifications ensure that responsible personnel can respond quickly. The affordable Plus-X EM connects to any on-site or off-site ARC Plus via LAN/WAN.

- Integrates with ARC Plus over existing LAN/WAN
- Supports a maximum of 32 sensors
- Built-in temperature, light and sound sensors
- Easily expandable with external sensors
- Integrates with IP security cameras
- Alert personnel via email, SMS and SNMP traps
- Spot trends and prevent problems from developing with onboard charting
- Onboard web interface for setup, historical monitoring and access, data and charts

PLUSX-EM32	List—\$895.00*
-------------------	----------------

Additional External Sensors

TEMPSENSOR	Temperature Sensor	List—\$109.00
HUMIDITY-SENSOR	Temperature/Humidity Sensor	List—\$125.00
SMOKE-DETECTOR	Smoke Detector	List—\$275.00
DOOR-CONTACT	Door Contact	List—\$15.00
MOTION SENSOR	Motion Sensor	List—\$90.00
FLOOD-DETECTOR	Flood and Leak Detector	List—\$150.00

*Prices too low to advertise. Call BSW for the lowest price 1-800-426-8434.

ARC NOW
REMOTE CONTROL - READY TO GO

Customized Remote Site Control

Burk's ArcNOW takes the effort out of remote control implementation. Describe your remote site to the experts at Burk, and your new ARC Plus or ARC Solo system will arrive ready to run with preconfigured monitoring and control points, automated functions using Jet™ Active Flowcharts, email and text alarm notification lists, periodic log capture, report distribution and AutoPilot™ custom views.

- Customized to your requirements
- Optimize your system design
- Get your system up and running faster

ARC-NOW	List—\$1,905.00*
----------------	------------------

*Prices too low to advertise. Call BSW for the lowest price 1-800-426-8434.



Simply Elegant Remote Site Control

The Burk ARC Solo includes many of the powerful features of the ARC Plus while offering the simplicity of a self contained remote control unit. 16 meters, status and relays are all available on the rear apron. Macros, email notifications and even a new recordable speech interface are built in. For smooth and easy remote control, the ARC Solo is a great choice.

- IP-based broadcast remote control
- Easy operator access via web, PC software, smartphone or telephone

ARC-SOLO	List—\$3,785.00*
-----------------	------------------

*Prices too low to advertise. Call BSW for the lowest price 1-800-426-8434.

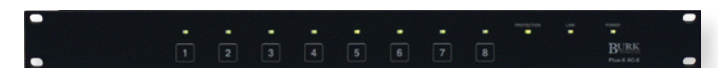

Remotely Reboots Digital Gear

The Plus-X AC-8 provides independent management of equipment connected to 120V outlets, allowing remote rebooting of digital gear. Broadcasters can also remotely manage HVAC, lighting and other appliances. It connects directly to the Burk ARC Plus remote control via Ethernet, or to any remote control (including the GSC3000 and ARC-16) using general-purpose inputs.

- Remotely power cycle and control equipment via AC
- Easy local control with front-panel buttons; built-in web control
- Ideal for use with the ARC Plus, easy to integrate with any remote control
- 100 to 132 VAC, 50/60 Hz
- 8' attached 14/3 grounded power cord
- 15A circuit breaker with reset button

PLUSX-AC-8	List—\$1,195.00*
-------------------	------------------

*Prices too low to advertise. Call BSW for the lowest price 1-800-426-8434.

VX Series

Compact • Efficient • Affordable

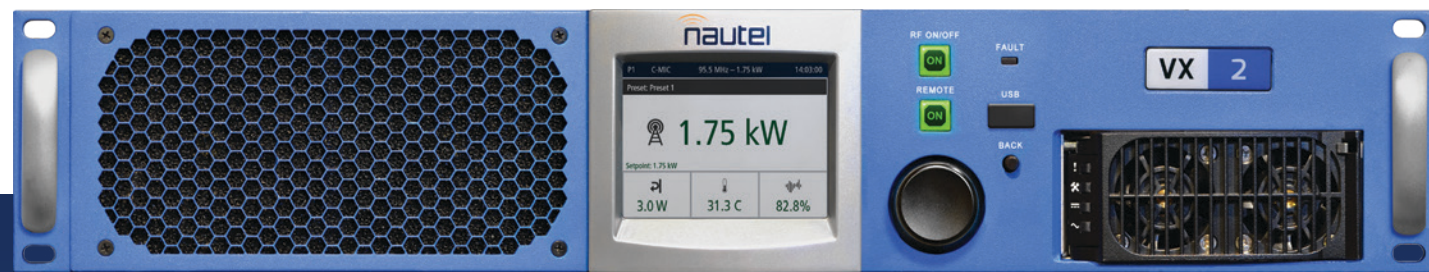

Analog Transmitters 150 W–6 kW FM

- 11 power choices to fit your needs
- AUI: Secure, HTML5 Tx Control
- Instrumentation, RDS, SNMP, Presets
- Modular 3-6 kW for easy service & low weight
- 100% North American: Design, Build, #1 Support
- Rigorous testing and quality assurance
- Long service-life design
- LPFM certified models
- 4 year warranty



BSW
www.bswusa.com

Call BSW for your best NAUTEL
price 1-800-426-8434

Shrink Your Energy Bill with Nautel and BSW

Nautel NX Series: Efficient, Energy-Saving Digital/Analog AM Transmitters

The NX Series features compact standalone transmitter designs with outputs from 3 kW to 50 kW. All models come standard with free MDCL power saving technology to significantly reduce your energy bills.

- AM pre-correction, unmatched linearity
- Industry's top efficiency
- 1.8 MHz direct digital modulation (NX300: 2.7 MHz)
- 17" touch screen on 25+ kW transmitters
- 100% remote web access to the user interface
- RF and audio spectrum analyzer
- Trimode: Analog, HD Radio®, all DRM modes
- Call BSW for a custom quote

NX3	Solid State modular 3 kW AM Transmitter *
NX5	Solid State modular 5 kW AM Transmitter
NX10	Solid State modular 10 kW AM Transmitter
NX25	Solid State modular 25 kW AM Transmitter
NX50	Solid State modular 50 kW AM Transmitter

Prices too low to advertise. Call BSW for the lowest price 1-800-426-8434.



FROM COMPACT RACK MOUNT TRANSMITTERS TO MASSIVE POWERHOUSES, BSW IS YOUR TRANSMITTER DEALER!

Call BSW for All Your Nautel Needs

With over 55 years of constant innovation, Nautel is the recognized world leader in the design, manufacture, sales and support of high power, solid-state RF products for radio.

BSW carries the full line of Nautel RF equipment, and can supply you with the gear you need, in any configuration. Give us a call or drop us an email and we'll get it for you at the best possible price.

NVLT Series: Highly Efficient FM Transmitters For Significant Energy Savings

The NVLT Series of solid-state, modular analog/digital FM transmitters features 3.5 kW to 40 kW transmitters boasting the highest efficiency in their class to deliver significant energy savings.

Each design is optimized to offer the features you want without the extra cost for external combiners, exciters, control systems, instrumentation or system rack. Extensive redundancy in all models offers outstanding reliability. Call BSW for a custom quote.

- Proven NV Series architecture
- Highest efficiency in its class (72%) for significant energy savings
- Integrated direct-to-digital exciter
- IP audio and streaming input
- Award winning instrumentation and control
- Intelligent VS Series features
- Automatic fail-safe audio source
- Parallel power amplifiers, parallel power modules and switching power supplies
- Easy path to HD Radio® operation
- Call BSW for a custom quote

NV3.5LT	3.5 kW, analog *
NV5LT	5 kW, analog
NV10LT	10 kW, analog

Prices too low to advertise. Call BSW for the lowest price 1-800-426-8434.



Industry-Leading Nautel Transmitters



GV² Series: Digital, Intelligent, Analog/ Digital FM Transmitters

Nautel GV² transmitters are the first in the industry capable of integrating all HD Radio™ components inside the transmitter. Engineered using Nautel's field-proven binary combined high-power architecture, they offer the industry's highest digital power outputs, commercial-grade instrumentation, advanced intelligent features and award-winning control via Nautel's AUI. Omnia® for Nautel covers all FM and HD Radio audio processing needs and provides Livewire® AoIP inputs for all audio streams.

- New IQ interface card
- New HTML AUI
- Embedded compute engine with 10X more processing power
- Optimized power supplies
- Solid state storage
- Virtualization Engine

GV2-3.5D	3.5 kW, digital *	GV2-7.5A	7.5 kW, analog
GV2-3.5A	3.5 kW, analog	GV2-7.5D	7.5 kW, digital
GV2.5A	2.5 kW, analog	GV2-10A	10 kW, analog
GV2.5D	2.5 kW, digital	GV2-10D	10 kW, digital

Prices too low to advertise. Call BSW for the lowest price 1-800-426-8434.

Low Power Single-Phase AC Transmitter

Power module integrating multiple RF amplifier units. The individual RF amplifiers and modulator units are connected to the power modules using plug-in industry standard "D" connectors and bolted directly to a heatsink. Servicing consists of simple exchange, using only a screwdriver. Component level repair can be performed at a workbench or near the transmitter using a convenient test cable that provides all test signals from the host transmitter.

- Automatic Standby
- Unattended Operation
- Maximum Redundancy
- Power outputs: 3 kW or 6 kW

XR3-1.PH	3 kW 1 phase, dual exciter, single phase AC *
XR6-1.PH	6 kW 1 phase, dual exciter, single phase AC

*Prices too low to advertise. Call BSW for the lowest price 1-800-426-8434.

Solid State, AM Broadcast Transmitter

The J1000 transmitter provides excellent functionality and flexibility for the broadcaster. The advanced PDM modulation correction and automatically adjusted power supply operation voltages yield low distortion figures from 10 watts to 1100 watts. Direct digital synthesis technology ensures a pure and stable RF carrier frequency that can be interfaced to a GPS reference.

- Redundant Architecture
- Excellent Sound Quality
- Built-in Scheduler
- Single Phase Power
- Simple Frequency Change
- Plug and Play

J1000	1kW AM Broadcast Transmitter *
--------------	--------------------------------

*Prices too low to advertise. Call BSW for the lowest price 1-800-426-8434.



More online!
Scan for full specs.

Nautel VX Transmitters: Lighter, Faster, Stronger



VX5



VX1

VX Series: Feature-Rich State-of-the-Art FM Transmitters

Nautel's VX Series of compact analog FM transmitters offers plenty of power options, including the most advanced type-certified Low Power FM transmitter available.

New features, superior audio performance, improved reliability, and a host of audio input and audio back-up sources make the upgrade to a VX Series Exciter one of the most cost effective, feature rich improvements you can make to your main or stand-by transmitter. Call or email for a custom quote.

- More power choices to fit your needs
- AUI: Secure, HTML5 transmitter control
- Instrumentation, RDS, SNMP, Presets
- Modular 3-6kW for easy service & low weight
- 100% North American design, build, #1 support
- Rigorous testing and quality assurance
- Long service-life design
- LPPM certified models
- 4-year warranty
- Call BSW for a custom quote

VX150	150 W FM Transmitter *	VX3	3kW FM Transmitter
VX300	300 W FM Transmitter	VX3.5	3.5kW FM Transmitter
VX600	600 W FM Transmitter	VX4	4kW FM Transmitter
VX1	1kW FM Transmitter	VX5	5kW FM Transmitter
VX1.5	1.5kW FM Transmitter	VX6	6kW FM Transmitter
VX2	2kW FM Transmitter		

*Prices too low to advertise. Call BSW for the lowest price 1-800-426-8434.

**CALL BSW FOR BEST PRICE! OPERATORS ARE
STANDING BY! (OK, THEY'RE PROBABLY SITTING).
800.426.8434**

At BSW, we stand behind all the gear we sell.
To do that, we'll need a key to your transmitter station.

800.426.8434

Jamie Singer, GearHead
JamieS@bswusa.com



Level up your FM broadcast



- up to **10 YEARS** WARRANTY
- APT IP DECODER inside
- Full RDS
- WEB streaming
- 5 band SOUND processor

Ecreso FM AiO Series

Are you looking for a low or medium power FM transmitter that will meet your needs for cost-efficiency, rock-solid transmission, and superior sound quality that your listeners will love?

Ecreso FM AiO Series is an advanced digital FM transmitter range that exceeds all expectations for new-gen FM radio broadcast. Available in 100W to 2kW, it hosts top-tier software features including a full RDS encoder, audio/MPX over IP input, 5-band sound processor, web streaming, and SmartFM. With its user-centric design, it simplifies radio operations and makes your life easier - less peripheral equipment, high repairability, and advanced control. You also protect your investment with FCC certification for 100W and 300W LPFM broadcasting, and for the entire range benefit from an optional warranty of up to 10 years. You also benefit from the convenience of a local repair center with technical support, located in Miami, FL.

Designed for commercial, non-commercial, community, religious, and educational FM radio broadcasters, Ecreso AiO Series is a game-changing FM transmitter that offers the market's lowest Total Cost of Ownership (TCO).

World-Class FM Transmitters



AIO-ESSENTIALS-1K

New Ecreso AiO Series: The Lowest Total Cost of Ownership

The Ecreso AiO series are the latest generation of Ecreso / WorldCast Systems transmitters. With up to 76% efficiency and the patented SmartFM technology (up to 40% energy savings), the new Ecreso transmitters provide the lowest electricity consumption on the market. The AiO series also brings together the expertise of APT and Audemat, resulting in a built-in APT IP Decoder with SureStream, APTmpX, and a full Audemat RDS Encoder. Additional features such as the direct-to-channel digital modulator, a 5-band sound processor and hot-swappable PA power supply complete this flagship FM transmitter.

ESSENTIALS: 2-year warranty and web GUI, Advanced Metering Interface, SNMP, IceCast streaming, Direct-to-channel digital modulator, wide-band sound processor, GPIO

AIO-ESSENTIALS-100	AiO series 100W (FCC certified)	List—\$3,490.00*
AIO-ESSENTIALS-300	AiO series 300W (FCC certified)	List—\$3,790.00
AIO-ESSENTIALS-600	AiO series 600W	List—\$4,590.00
AIO-ESSENTIALS-1K	AiO series 1kW	List—\$5,590.00
AIO-ESSENTIALS-2K	AiO series 2kW	List—\$8,690.00

*Prices too low to advertise. Call BSW for the lowest price 1-800-426-8434.



- +60 YEARS OF FM RADIO expertise
- APT Inside
- Full RDS
- 5 band SOUND processor
- up to 10 YEARS WARRANTY
- FCC Certified

PERFORM: 4-year warranty, Essentials version and Surge protector, Dynamic RDS, 5-band sound processor **OR** APT IP Decoder (with SureStream and APTmpX)

AIO-PERFORM-100	AiO series 100W (FCC certified)	List—\$4,590.00*
AIO-PERFORM-300	AiO series 300W (FCC certified)	List—\$4,890.00
AIO-PERFORM-600	AiO series 600W	List—\$5,690.00
AIO-PERFORM-1K	AiO series 1kW	List—\$6,690.00
AIO-PERFORM-2K	AiO series 2kW	List—\$9,790.00

*Prices too low to advertise. Call BSW for the lowest price 1-800-426-8434.

EXTREME: 10-year warranty, Perform version and Surge protector, Full RDS encoder (UECP compatible), 5-band sound processor, APT IP Decoder (with SureStream and APTmpX), SmartFM

AIO-EXTREME-100	AiO series 100W (FCC certified)	List—\$5,990.00*
AIO-EXTREME-300	AiO series 300W (FCC certified)	List—\$6,490.00
AIO-EXTREME-600	AiO series 600W	List—\$6,990.00
AIO-EXTREME-1K	AiO series 1kW	List—\$7,990.00
AIO-EXTREME-2K	AiO series 2kW	List—\$12,990.00

*Prices too low to advertise. Call BSW for the lowest price 1-800-426-8434.

ASK ABOUT FINANCING YOUR NEXT TRANSMITTER WITH BSW CALL 1.800.426.8434!

Efficient Ecreso FM Transmitter Series

Engineered to meet the needs of the most demanding network operators and stations, Ecreso FM 3kW, 5kW & 10kW combine reliable performance, high efficiency of up to 76%, and advanced technology into a compact, yet modular design. At the heart of the transmitter, the direct-to-frequency digital modulator feeds the RF stage with an extremely pure and high-quality signal while hosting many on-boards features:

- SmartFM
- 5-band sound processor
- Dynamic RDS
- Audio backup
- Web GUI
- GPIO
- 3-year standard warranty
- Up to 10-year warranty

EFM-ESSENTIALS-3K	FM 3kW – Essentials	List—\$13,390.00*
EFM-PERFORM-3K	FM 3kW – Perform	List—\$14,490.00
EFM-EXTREME-3K	FM 3kW – Extreme	List—\$17,990.00
TF01205-RT03	FM 5kW	List—\$51,929.00
TF01206-RT03	FM 10kW	List—\$69,591.00

*Prices too low to advertise. Call BSW for the lowest price 1-800-426-8434.



EFM-ESSENTIALS-3K

TF01206-RT03

Efficient, Versatile FM Transmitters



Efficient NiCOM FM Exciter/Transmitters

NiCOM's NT Series of phase-locked loop programmable FM exciter/transmitters are meticulously designed and feature high-quality components for years of trouble-free use. Available in models with up to 5000 watts of output power, they offer ultra-efficient MOSFET technology, a frequency range of 87.5 MHz to 108 MHz and an easy-to-use control interface.

- Includes low pass/harmonic filter
- Instant front panel programmability in 10 kHz increments
- Adjustable power output with automatic power control
- All functions via LCD password protected
- Frequency range: 87.5 MHz to 108 MHz
- Frequency stability: better than 5 ppm (± 500 Hz)
- Modulation type: direct carrier frequency modulation
- FCC and Industry Canada approved

NT30	FM transmitter 30w "N" type connector	List—\$1,990.00 *
NT-30H	FM transmitter 50w "N" type connector	List—\$2,090.00
NT150-LCD	FM transmitter 150w "N" type connector	List—\$3,090.00
NT250-LCD	FM transmitter 250w "N" type connector	List—\$3,190.00
NT500-LCD	FM transmitter 500w "N" type connector	List—\$4,190.00
NT1000-LCD	FM transmitter 1000w "7/16" EIA connector	List—\$5,390.00
NTI2000	FM transmitter 2000w "7/16" EIA connector with stereo / RDS / TCP/IP remote	List—\$9,990.00

*Prices too low to advertise. Call BSW for the lowest price 1-800-426-8434.



High Performance FM Transmitters

Crown Broadcast FM transmitters feature a built-in audio processor and stereo generator (higher power models also include an exciter) and deliver a consistently high level of performance.

Boasting low loss circuit boards and copper heat spreaders in the RF chain, they function with less heat and improved life span. A robust power supply with switching voltage and power regulators for AC or DC operation let you use them anywhere power can be generated.

- Low/Medium/High power transmitters with built-in audio processor and stereo generator FM1000T
- 87-108 MHz user-selectable frequency range
- Frequency Agile from front panel
- SWR metering from remote control
- Ability to control output power from remote control
- 3-Year warranty
- 24-hour service support
- Meets or exceeds all FCC requirements

FM30T	3W - 30W FM transmitter	List—\$4,045.00 *
FM150T	15W - 150W FM transmitter	List—\$5,145.00
FM300T	30W - 300W FM transmitter	List—\$6,900.00
IREC-CLASSIC	Remote interface for Crown Classic transmitters	List—\$850.00

*Prices too low to advertise. Call BSW for the lowest price 1-800-426-8434.

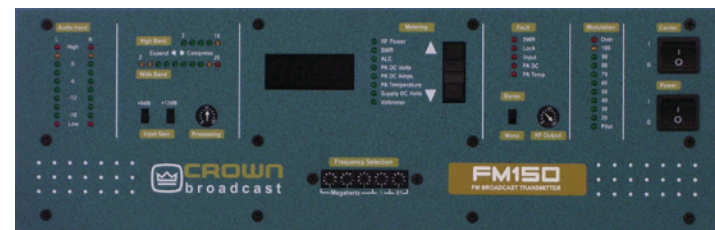

FM150T



IREC-CLASSIC

CALL BSW FOR LOWEST PRICES! 1.800.426.8434

Premium AAT FM Radio Transmitters



American Amplifier Technologies, LLC

American Amplifier Technologies FM Radio Digital Transmitters

American Amplifier Technologies (AAT) solid-state digital FM transmitters are meticulously designed and produced with quality materials and rigorous engineering standards to deliver many years of superb performance.

These solid-state, frequency-agile FM transmitters feature efficient state-of-the-art transistors and power supplies, and utilize power LDMOS technology with extensive monitoring via Ethernet and Remote Samples

Contact a BSW GearHead to find the configuration that's ideal for your FM transmission needs.

- Frequency agile 87.5 - 108MHz
- Efficient state-of-the-art transistors and power supplies
- Extensive monitoring via Ethernet and Remote Samples
- Solid state power MOSFET technology (1, 2, 3 kW models)
- Solid state power LDMOS technology (5, 6 KW models)
- 2-year warranty

AAT-FM-50	50 Watt FM-Series transmitter	List—\$4,625.00 *
AAT-FM-150	150 Watt FM-Series transmitter	List—\$4,941.00
AAT-FM-300	300 Watt FM-Series transmitter	List—\$5,673.00
AAT-FM-500	500 Watt FM-Series transmitter	List—\$6,270.00
AAT-FM-750	750 Watt FM-Series transmitter	List—\$6,391.00
AAT-FM-1000	1000 Watt FM-Series transmitter	List—\$8,851.00
AAT-FM-1500	1500 Watt FM-Series transmitter	List—\$12,209.00
AAT-FM-2000	2000 Watt FM-Series transmitter	List—\$15,643.00
AAT-FM-2500	2500 Watt FM-Series transmitter	List—\$16,786.00
AAT-FM-3000	3000 Watt FM-Series transmitter	List—\$18,500.00
AAT-FM-3500	3500 Watt FM-Series transmitter	List—\$21,214.00
AAT-FM-4000	4000 Watt FM-Series transmitter	List—\$26,500.00
AAT-FM-5000	5000 Watt FM-Series transmitter	List—\$33,643.00
AAT-FM-6000	6000 Watt FM-Series transmitter	List—\$37,929.00
AAT-FM-8000	8000 Watt FM-Series transmitter	List—\$52,214.00
AAT-FM-10000	10000 Watt FM-Series transmitter	List—\$65,071.00
AAT-FM-12000	12000 Watt FM-Series transmitter	List—\$69,357.00
AAT-FM-15000	15000 Watt FM-Series transmitter	List—\$76,500.00
AAT-FM-20000	20000 Watt FM-Series transmitter	List—\$123,643.00
AAT-FM-25000	25000 Watt FM-Series transmitter	List—\$137,929.00
AAT-FM-30000	30000 Watt FM-Series transmitter	List—\$143,571.00
AAT-FM-40000	40000 Watt FM-Series transmitter	List—\$253,643.00
AAT-FM-60000	60000 Watt FM-Series transmitter	List—\$278,571.00

*Prices too low to advertise. Call BSW for the lowest price 1-800-426-8434.

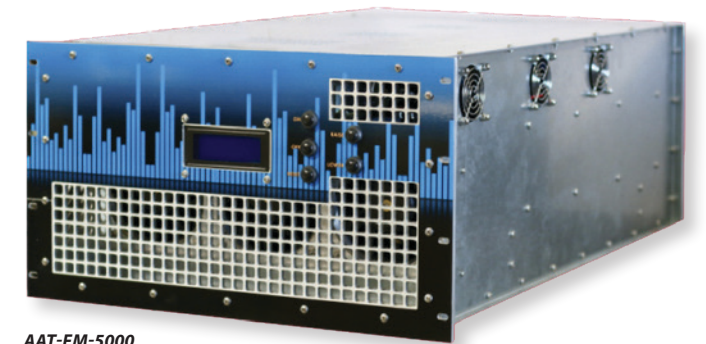

AAT-FM-5000



AAT-FM-1000

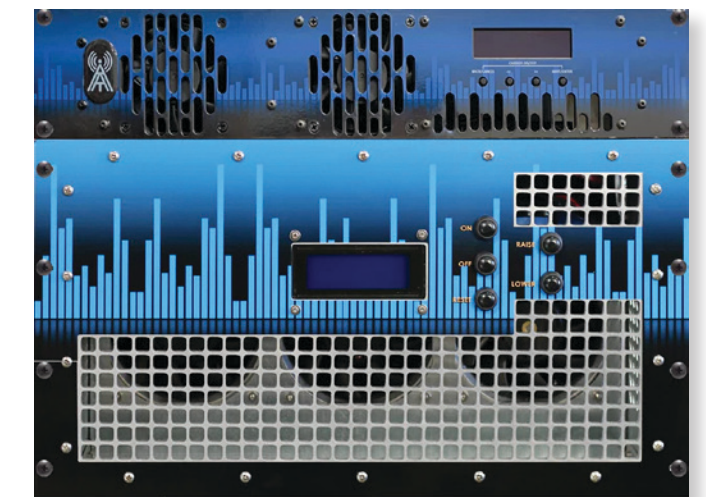

FM SERIES TRANSMITTER

CLASS LEADING FEATURES: STEREO ENCODER, RBDS/RDS GENERATOR, & SCA

Make Your FM Signals Crystal-Clear With Premium AAT Bandpass Filters

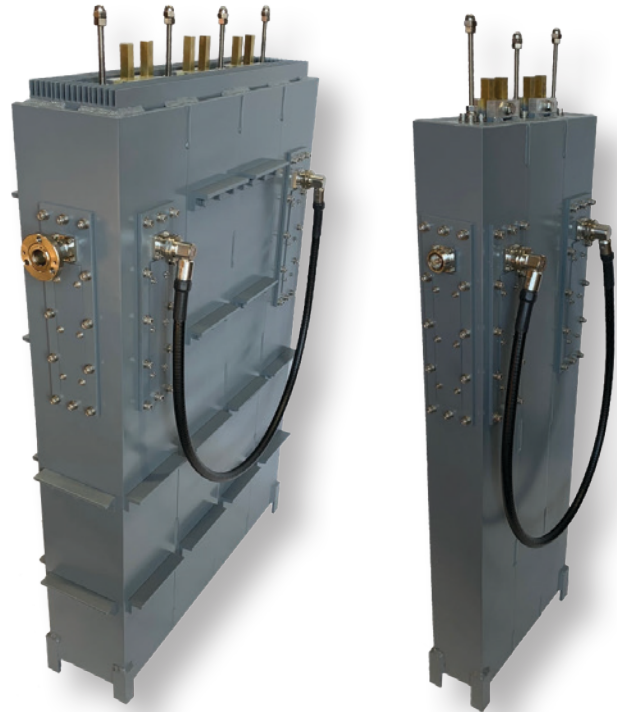

American Amplifier Technologies FM Bandpass Filters

American Amplifier Technologies (AAT) broadcast filters are designed using a high quality aluminum iris couple cavity. Each band pass filter unit provides 400 kHz of passband bandwidth. The cross coupled notch networks are provided as an option when additional attenuation is needed at 2 MHz or less from the pass band channel. Excellent for both analog and digital operations, 1 kW through 60 kW systems are available.

- 88-108 MHz
- High-quality aluminum, brass, and copper materials
- Floor, ceiling, or wall-mount configurations
- No finger stock use
- Cross coupled



BP-IR-2-1K	1kW 2-cavity bandpass filter	List—\$3,548.00 *
BP-IR-3-1K	1kW 3-cavity bandpass filter	List—\$4,032.00
BP-IR-4-1K	1kW 4-cavity bandpass filter	List—\$4,355.00
BP-IR-2-1.5K	1.5kW 2-cavity bandpass filter	List—\$4,508.00
BP-IR-3-1.5K	1.5kW 3-cavity bandpass filter	List—\$4,758.00
BP-IR-4-1.5K	1.5kW 4-cavity bandpass filter	List—\$5,081.00
BP-IR-2-3K	3kW 2-cavity bandpass filter	List—\$5,323.00
BP-IR-3-3K	3kW 3-cavity bandpass filter	List—\$5,565.00
BP-IR-4-3K	3kW 4-cavity bandpass filter	List—\$5,887.00
BP-IR-2-7K	7kW 2-cavity bandpass filter	List—\$6,927.00
BP-IR-3-7K	7kW 3-cavity bandpass filter	List—\$7,250.00
BP-IR-4-7K	7kW 4-cavity bandpass filter	List—\$7,895.00
BP-IR-2-12K	12kW 2-cavity bandpass filter	List—\$7,984.00
BP-IR-3-12K	12kW 3-cavity bandpass filter	List—\$9,113.00
BP-IR-4-12K	12kW 4-cavity bandpass filter	List—\$9,919.00
BP-IR-2-20K	20kW 2-cavity bandpass filter	List—\$11,282.00
BP-IR-3-20K	20kW 3-cavity bandpass filter	List—\$11,653.00
BP-IR-4-20K	20kW 4-cavity bandpass filter	List—\$12,718.00
BP-IR-2-40K	40kW 2-cavity bandpass filter	List—\$12,823.00
BP-IR-3-40K	40kW 3-cavity bandpass filter	List—\$15,403.00
BP-IR-4-40K	40kW 4-cavity bandpass filter	List—\$20,242.00
BP-IR-2-60K	60kW 2-cavity bandpass filter	List—\$15,403.00
BP-IR-3-60K	60kW 3-cavity bandpass filter	List—\$18,629.00
BP-IR-4-60K	60kW 4-cavity bandpass filter	List—\$25,000.00

BP-IR-2-1K-N	1kW 2-cavity bandpass filter with notch	List—\$4,000.00 *
BP-IR-3-1K-N	1kW 3-cavity bandpass filter with notch	List—\$4,500.00
BP-IR-4-1K-N	1kW 4-cavity bandpass filter with notch	List—\$4,917.00
BP-IR-2-1.5K-N	1.5kW 2-cavity bandpass filter with notch	List—\$4,917.00
BP-IR-3-1.5K-N	1.5kW 3-cavity bandpass filter with notch	List—\$5,333.00
BP-IR-4-1.5K-N	1.5kW 4-cavity bandpass filter with notch	List—\$5,667.00
BP-IR-2-3K-N	3kW 2-cavity bandpass filter with notch	List—\$5,833.00
BP-IR-3-3K-N	3kW 3-cavity bandpass filter with notch	List—\$6,250.00
BP-IR-4-3K-N	3kW 4-cavity bandpass filter with notch	List—\$6,583.00
BP-IR-2-7K-N	7kW 2-cavity bandpass filter with notch	List—\$8,158.00
BP-IR-3-7K-N	7kW 3-cavity bandpass filter with notch	List—\$8,417.00
BP-IR-4-7K-N	7kW 4-cavity bandpass filter with notch	List—\$8,750.00
BP-IR-2-12K-N	12kW 2-cavity bandpass filter with notch	List—\$8,917.00
BP-IR-3-12K-N	12kW 3-cavity bandpass filter with notch	List—\$10,083.00
BP-IR-4-12K-N	12kW 4-cavity bandpass filter with notch	List—\$10,750.00
BP-IR-2-20K-N	20kW 2-cavity bandpass filter with notch	List—\$13,083.00
BP-IR-3-20K-N	20kW 3-cavity bandpass filter with notch	List—\$13,417.00
BP-IR-4-20K-N	20kW 4-cavity bandpass filter with notch	List—\$14,083.00
BP-IR-2-40K-N	40kW 2-cavity bandpass filter with notch	List—\$14,250.00
BP-IR-3-40K-N	40kW 3-cavity bandpass filter with notch	List—\$17,083.00
BP-IR-4-40K-N	40kW 4-cavity bandpass filter with notch	List—\$22,583.00
BP-IR-2-60K-N	60kW 2-cavity bandpass filter with notch	List—\$19,250.00
BP-IR-3-60K-N	60kW 3-cavity bandpass filter with notch	List—\$22,583.00
BP-IR-4-60K-N	60kW 4-cavity bandpass filter with notch	List—\$27,583.00

*Prices too low to advertise. Call BSW for the lowest price 1-800-426-8434.

More Awesome AAT RF Gear



AAT Dummy Loads: the Smart Choice

RF dummy loads simulate the presence of an antenna load without radiating any electromagnetic energy. They are designed to absorb RF power and dissipate it as heat. This prevents the RF energy from being radiated as electromagnetic waves, which could interfere with other RF systems. Dummy loads are usually designed to match the impedance of the RF system. This impedance matching ensures that the RF power is absorbed efficiently and minimizes reflections that could cause signal distortion or damage to the RF system. They are also used in testing and calibration of RF equipment. They provide a stable and controlled load for testing

the performance of RF transmitters, amplifiers, and other RF components. By simulating the presence of an antenna load, they allow accurate measurements and adjustments to be made without radiating the RF energy.

American Amplifier Technologies (AAT) designs their dummy loads to operate superbly for with many years. AAT dummy loads are designed and produced with quality materials, simplicity, and rigorous engineering standards, ensuring the dummy loads deliver outstanding performance day in and day out. Contact a BSW GearHead to get the lowdown on BSW's wide selection of AAT dummy loads.

DL-1K-RM	1 kW rack mountable dummy load, 3U, 120 / 220 VAC 50/60Hz	\$3,850.00
DL-2K-RM	2 kW rack mountable dummy load, 3U, 120 / 220 VAC 50/60Hz	\$4,550.00
DL-3K-RM	3 kW rack mountable dummy load, 3U, 120 / 220 VAC 50/60Hz	\$5,560.00
DL-1K-RM-MODULE	1 kW rack mountable load module for DL-RM units	\$1,720.00
DL-2K-RM-MODULE	2 kW rack mountable load module for DL-RM units	\$1,995.00
DL-3K-RM-MODULE	3 kW rack mountable load module for DL-RM units	\$2,750.00
DL-5K	5 kW dummy load	\$4,594.00
DL-10K	10 kW dummy load	\$5,280.00
DL-25K	25 kW dummy load	\$9,544.00
DL-50K	50 kW dummy load	\$14,988.00
DL-75K	75 kW dummy load	\$20,206.00

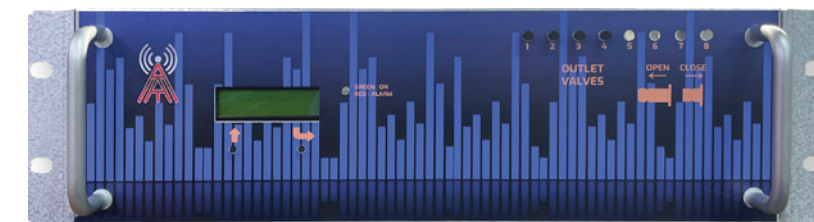

Trust in BSW and Keep Your Waveguide Dry

AAT's rack mountable dehydrators banish moisture in a transmitter's waveguide, eliminating reflected energy that can increase the Standing Wave Ratio (SWR) of the system. These ultra-reliable models provide local alarms for power and system failures, low/high pressure, and high humidity. The RM-DEH-IP's remote monitoring interface offers 10/100 BaseT ethernet, auto-sensing with the following protocols: HTTP, TCP/IP, SNMP, TFTP, FTP, Telnet and DHCP.

- Maximum flow rate is 254 SCFD (300 l/h)
- Safety valve factory set at 10 PSI +/-15%
- Desiccant regeneration is automatic by heating
- Enclosure protection is IP20 according to IEC529
- Dimensions: 5.2" H x 19" W x 9.4" D
- Net weight: 14.3 lbs (6.5 kg)

- Designed for continuous operation and automatic duty
- Continuous tracking of output pressure through Pulse Width Modulation (PWM)
- Output pressure programmable from 1.5– 7 PSI

RM-DEH	Rack mountable dehydrator	List \$6,133.00*
RM-DEH-IP	Rack mountable dehydrator with IP remote interface	List \$7,196.00

*Prices too low to advertise. Call BSW for the lowest price 1-800-426-8434.



Double your bang. For half the bucks.

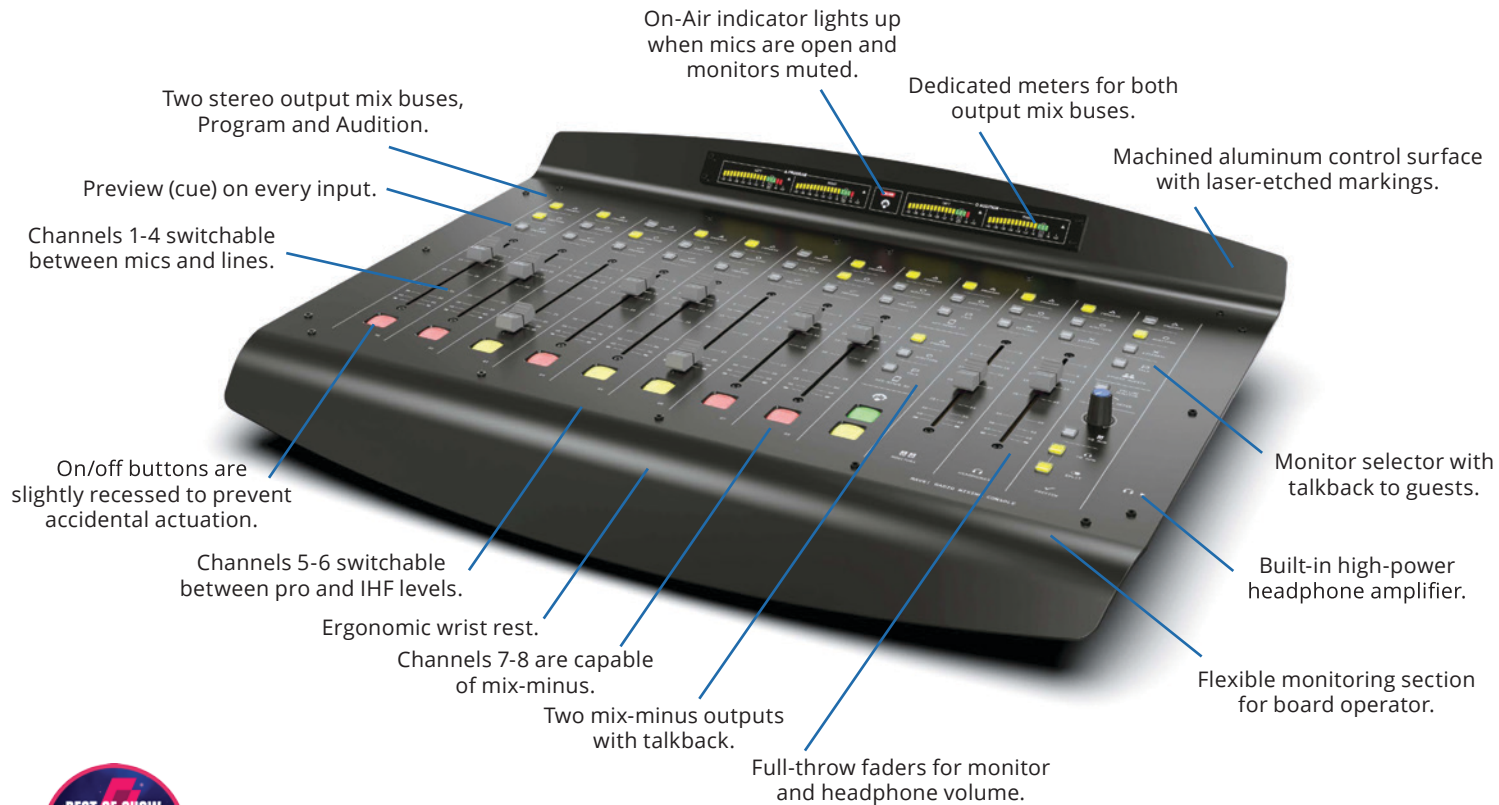

RAVE! Radio mixing console.
\$2,199 MSRP. Yes way.

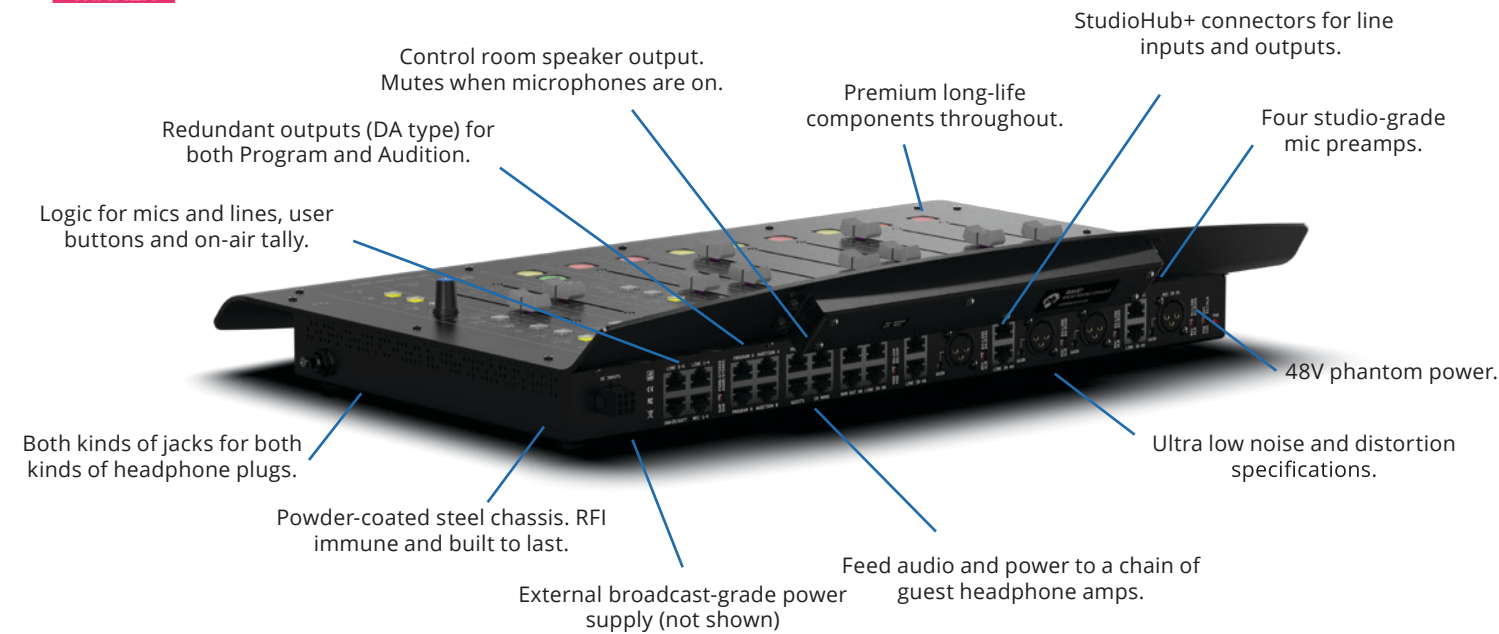

P4200W



P210WLP-V

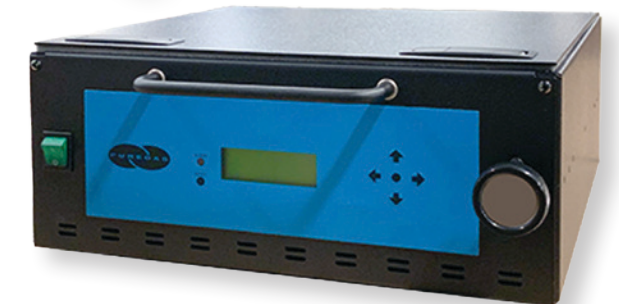

P210WLP

Kiss Moisture Goodbye with Altec Dehydrators

RF dehydrators are designed to remove moisture from the transmission lines and waveguides used in radio broadcasting. Moisture can cause signal loss, interference, and corrosion, leading to degraded performance and equipment damage. By effectively controlling moisture levels, RF dehydrators help maintain the integrity of the radio signals and ensure optimal transmission quality. They also remove moisture in transmission lines. Moisture can cause variations in the impedance, resulting in signal distortion, reduced coverage, and poor reception. Dehydrators ensure consistent signal transmission and reception. Moisture can also be detrimental to

the sensitive electronic components used in radio broadcasting equipment. It can cause short circuits, corrosion, and other forms of damage, leading to equipment malfunction or failure. RF dehydrators extend the lifespan and reliability of the broadcasting system. By preventing signal degradation and equipment damage, RF dehydrators help reduce maintenance and repair costs.

Altec dehydrators are carefully designed and constructed of the finest materials, ensuring superb performance and long life. Contact a BSW GearHead to take advantage of BSW's huge selection of AAT dehydrators.

P210WLP	Waveguide Dehydrator 110 - 125 VAC, 50/60 Hz	\$11,579.00	P1502W	Waveguide Dehydrator 208 - 253 VAC, 50/60 Hz	\$7,141.00
P210WLP-V	Waveguide Dehydrator 110 - 125 VAC, 50/60 Hz with Vertical Mount Installation	\$6,876.00	P1502WHP	Waveguide Dehydrator 208 - 253 VAC, 50/60 Hz with Outdoor Enclosure	\$9,272.00
P212WLP	Waveguide Dehydrator 208 - 253 VAC, 50/60 Hz	\$6,747.00	P1502WHPX	Waveguide Dehydrator 208 - 253 VAC, 50/60 Hz with Outdoor Enclosure	\$9,272.00
P212WLP-V	Waveguide Dehydrator 208 - 253 VAC, 50/60 Hz with Vertical Mount Installation	\$6,474.00	P1502WLP	Waveguide Dehydrator 208 - 253 VAC, 50/60 Hz with Outdoor Enclosure	\$8,757.00
P1500W	Waveguide Dehydrator 110 - 125 VAC, 50/60 Hz	\$7,141.00	P1502WLPX	Waveguide Dehydrator 208 - 253 VAC, 50/60 Hz with Outdoor Enclosure	\$9,272.00
P1500WHP	Waveguide Dehydrator 110 - 125 VAC, 50/60 Hz with Outdoor Enclosure	\$11,579.00	P1502WX	Waveguide Dehydrator 208 - 253 VAC, 50/60 Hz with Outdoor Enclosure	\$10,371.00
P1500WHPX	Waveguide Dehydrator 110 - 125 VAC, 50/60 Hz with Outdoor Enclosure	\$9,272.00	P4200W	Waveguide Dehydrator 110 - 125 VAC, 50/60 Hz	\$10,959.00
P1500WLP	Waveguide Dehydrator 110 - 125 VAC, 50/60 Hz	\$8,757.00	P4200WLP	Waveguide Dehydrator 110 - 125 VAC, 50/60 Hz	\$10,959.00
P1500WLPX	Waveguide Dehydrator 110 - 125 VAC, 50/60 Hz with Outdoor Enclosure	\$11,296.00	P4202W	Waveguide Dehydrator 220 - 230 VAC, 1-Phase, 50/60 Hz	\$10,661.00
P1500WX	Waveguide Dehydrator 110 - 125 VAC, 50/60 Hz with Outdoor Enclosure	\$10,370.00	P4202WLP	Waveguide Dehydrator 220 - 230 VAC, 1-Phase, 50/60 Hz	\$10,959.00

Get Pristine Signal Integrity with AAT

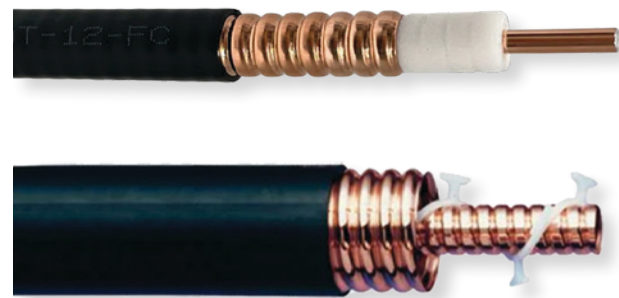

AAT Coaxial Line and Connectors

RF coaxial cables are a great choice for delivering high-quality audio, video, and data transmissions. Boasting a unique construction that includes an inner conductor, an insulating layer, a metallic shield, and an outer jacket, coaxial cables are designed to minimize electromagnetic interference (EMI) and ensure maximum signal integrity.

RF coaxial connectors are vital to maintaining the performance and reliability of these cables. Common types of connectors, such as DIN, N-type, and EIA ensure a strong, secure link that preserves the cable's signal integrity while providing the versatility needed for RF applications.

American Amplifier Technologies' (AAT) coaxial cables are crafted with precision and care, utilizing high-grade materials to enhance durability and environmental resistance. This commitment to quality results in cables that can withstand the rigors of both indoor and outdoor use, offering exceptional performance in any setting. Paired with AAT's reliable connectors, these cables will transmit data at high speeds and resolutions, facilitating seamless, uninterrupted streaming of clear, crisp audio. **Contact a BSW GearHead for full info on these fine cables and connectors.**

RG11 Coax:

AAT-RG11	RG11 Coaxial line - 75 ohm	List—\$12.40*
RG11-TYPEFM	RG11 Type-F male connector	List—\$4.25
RG11-TK	RG11 Crimp tool kit	List—\$75.00

1/2in Standard/Super Flex Coax:

AAT-12-COAX-F	1/2" standard 50 ohm foam coax	List—\$4.25
N-M-12	1/2" type N Female coax connector	List—\$30.00
N-M-12MALE	1/2" type N male coax connector	List—\$30.00
716-12C	7/16" DIN Male coax connector	List—\$40.00
716-12C-90	7/16" DIN Male 90° coax connector	List—\$46.00
78-EIA-12-CC	7/8" EIA connector w/ O ring, kit	List—\$190.00
AAT-12-COAX-SF	1/2" Super Flex 50 ohm foam coax	List—\$4.60
AAT-N-M-12-SF	Type N Male for 1/2" Super Flex	List—\$31.00
AAT-N-M-12-SF-90	90° Type N Male for 1/2" Super Flex	List—\$51.00
AAT-716-12C-SF	7/16" DIN Male 1/2" Super Flex	List—\$56.00
AAT-716-12C-SF90	90° DIN Male for 1/2" Super Flex	List—\$66.00

7/8in Foam/Air Coax:

AAT-78-COAX-F	7/8" 50 ohm foam coax	List—\$8.75
AAT-78-CC-78-AAT	7/8" EIA connector for foam coax	List—\$310.00
ATT-78-CC-78-RSB	7/8" EIA CN for Rosenberger coax	List—\$310.00
AAT-78-CC-78-LCF78-50	7/8" EIA CN for coax RFS LCF78-50	List—\$310.00
AAT-78-CC-78-AVA5-50	7/8" EIA for Commscope AVA5-50	List—\$310.00
AAT-78-CC-78-LDF5-50A	7/8" EIA for Andrew LDF5-50A	List—\$310.00
AAT-78-CC-78-EC5-50-A	7/8" EIA for Eupen EC5-50-A	List—\$310.00
AAT-716-78C	7/16" DIN Male for 7/8" foam cable	List—\$310.00
AAT-78-AC	7/8" 50 ohm Air Pass	List—\$92.00
AAT-78-CC-78-CA	7/8" EIA for 7/8" Air Pass coax	List—\$8.75

1-5/8in Foam/Air Coax:

158-EIA-158-C	1-5/8" EIA for 1-5/8" foam coax	List—\$625.00
158-EIA-158-C-AVA7-50	1-5/8" EIA for Andrew AVA7-50	List—\$425.00
158-EIA-158-C-LDF7-50A	1-5/8" EIA for Andrew LDF7-50A	List—\$425.00
158-EIA-158-C-LCF158-50A	1-5/8" EIA for RFS LCF158-50A	List—\$425.00
AAT-158-AC	1-5/8" 50 ohm air pass	List—\$15.80
158-EIA-158-CA	1-5/8" EIA for air pass coax	List—\$425.00

3-1/8in / 4in / 5in Air Coax:

AAT-HC318-AC	3-1/8" 50 ohm air coax	List—\$52.13
HC318-AC-318C	3-1/8" EIA connector for 3" air coax	List—\$1,652.00
HC40-AC-4C	4" 50 ohm air coax	List—\$62.45
HC40-AC-318C	4" 50 ohm air 3-1/8" connector	List—\$1,950.00
HC50-AC-5C	5" 50 ohm air coax	List—\$208.00
HC50-AC-618C	5" 50 ohm air 6-1/8" connector	List—\$3,250.00

Coax Accessories:

AAT-12-H	1-5/8" butterfly hanger, 10 per kit	List—\$31.00
AAT-78-H	1-7/8" butterfly hanger, 10 per kit	List—\$31.00
AAT-158-H	1-5/8" butterfly hanger, 10 per kit	List—\$39.00
AAT-30-H	3" butterfly/clamp hanger, 10 in kit	List—\$164.00
AAT-40-H	3-1/8" & 4" b-fly/clamp hangers, 10	List—\$177.00
AATGK-12	1/2" ground kit	List—\$39.00
AATGK-78	7/8" ground kit	List—\$51.00
AATGK-158	1-5/8" ground kit	List—\$51.00
AATGK-30	3" ground kit	List—\$65.00
AATGK-40	3-1/8" and 4" ground kit	List—\$78.00
AATHOIST-12	1/2" hoist grip, lace up	List—\$31.00
AATHOIST-78	7/8" hoist grip, lace up	List—\$35.00
AATHOIST-158	1-5/8" hoist kit, lace up	List—\$35.00
AATHOIST-30	3" hoist grip, lace up	List—\$153.00
AATHOIST-40	3-1/8" and 4" hoist grip, lace up	List—\$146.00
AAT-BC	Angle Adapter, beam clamp kit, 10	List—\$93.00
AAT-3850	Round member standoff	List—\$55.00
AAT-HGK-6-CTS	Turnbuckle and chain kit	List—\$133.00
AAT-SE-P-4INCH	Entry Panel 4 x 4 (for 4" boots)	List—\$35.00
AAT-4IN-BOOT-NOINSERT	4" boot assembly (no insert)	List—\$31.00
AAT-BOOT-INSERT-78-3	7/8" coax 3-hole entry boot insert	List—\$20.00
AAT-BOOT-INSERT-781123	7/8" one-hole & 1/2" three-hole	List—\$20.00
AAT-BOOT-INSERT-158	1-5/8" one-hole entry boot insert	List—\$24.00
AAT-BOOT-INSERT-129	1/2" nine-hole entry boot insert	List—\$20.00
AAT-12-HC-9H-RB	1/2" nine hole cushion hanger (5)	List—\$61.00
AAT-78-1H-12-3H-RB	7/8" one-hole, 1/2" 3-hole, cushion	List—\$61.00
AAT-78-3H-RB	7/8" cushion hanger, 3-hole, (5)	List—\$61.00

*Prices too low to advertise. Call BSW for the lowest price 1-800-426-8434.



DB4005



DB7007

In-Depth Radio Monitoring from DEVA Broadcast

DEVA Broadcast offers a wide range of innovative, high-performance, cost-effective radio monitoring equipment for your specific needs. Call or visit our website for more details on DEVA Broadcast gear.

DB4005	SDR-Based FM Radio Monitor	List—\$3,495.00	\$3,145.50
DB7007	Advanced Re-Broadcast Receiver	List—\$2,650.00	\$2,385.00
BS-2	Band Scanner 2, FM & MOD Analyzer, RDS Decoder, built-in GPS receiver for signal coverage survey	List—\$1,450.00	\$1,305.00
BS-GPS	Band Scanner GPS - FM Band Spectrum & Mod Analyzer, RDS/RBDS Decoder-Reader with built-in GPS Receiver	List—\$1,425.00	\$1,282.50
BS-PRO	FM Band Spectrum and Mod Analyzer	List—\$1,150.00	\$1,035.00



DB8009

MPX and Audio Silence Monitor with Advanced Backup Capabilities

DB8009-MPX guarantees highly dependable monitoring of the Composite Stereo signal, Analog and Digital Audio feed and in case of signal loss automatically switches over to a backup source. The most notable advantage of this product, however, are the MPX inputs and outputs providing reliable MPX backup capability. In addition to that, it also offers built-in MP3 and IP Audio backup source options and incorporates a fully DSP-based core. Another important feature is its capability for alert notifications which, in case radio silence is detected, can be generated via email, SNMP or analog opto-coupled outputs. The device provides UPnP for easy discovery in local networks, as well as digital volume control of all audio sources, and can be incorporated effortlessly into the setup of either a single station or large radio networks.

DB8009-MPX	MPX & Audio Silence Monitor with Advanced Backup Capabilities	List—\$2,690.00	\$2,421.00
DB8008	Digital Silence Monitor with MP3 and IP Audio Backup Players	List—\$2,450.00	\$2,205.00



NEW

DB45

DB45	FM Radio Receiver and Modulation Analyzer	List—\$1,850.00	\$1,665.00
DB7002	Professional FM/DAB/DAB+ Monitoring Receiver	List—\$3,000.00	\$2,700.00
DB6400	Advanced FM and Digital Radio 4-Band Audio Processor with Backup Audio Player	List—\$2,695.00	\$2,425.50



RADIO-EXPL3-HD

On-the-Go HD Radio and DAB/DAB+ Radio Analyzers

The DEVA Radio Explorer III HD Radio boasts an FM tuner and an FM/HD tuner for precision and versatility. It measures all important signal parameters, including RF level, MPX deviation, Left & Right Audio levels values, DAAI and CDNR. It also features a built-in FM RDS/RBDS Decoder, an HD Radio PAD Decoder, as well as a Loudness Meter. The Radio Explorer III DAB features two powerful DAB tuners for superb accuracy and reliability. Besides measuring all important DAB signals, it can also monitor up to 10 services. It stores all measured parameters in a log file for further analysis through the DEVA Device Manager software.

RE3-FM	Radio Explorer III FM, Third Generation Mobile FM	List—\$3,950.00	\$3,145.00
RE2-FM	Radio Explorer II, Mobile FM Radio Analyzer	List—\$3,650.00	\$3,285.00
RE1-FM	Radio Explorer, Mobile FM Radio Analyzer	List—\$2,350.00	\$2,115.00



RDS Encoding with High Quality Spectral Purity

The Audemat RDS Encoder boasts an integrated RDS encoder and offers high quality spectral purity along with a handy built-in FM tuner. It also provides 16 inputs, eight relay outputs, MPX over AES, SNMP management and much more.

AUDEMAT-RDS-ENCODER	List—\$3,139.00 *
AUDEMAT-RDS-ENCODER-LT	List—\$2,090.00

*Prices too low to advertise. Call BSW for the lowest price 1-800-426-8434.

- Audemat ScriptEasy powerful performance
- RDS2 ready
- MPX over AES removes the last analog link from your chain
- Built-in FM tuner (standard in US version)
- ScriptEasy software for configuration and remote administration
- MasterView for customized end-user views of data and control
- SNMP Management
- UECP Control
- Future-proof platform



For Smooth Broadcast Monitoring



Triple Your Pleasure

The Inovonics 677 Triple Tuner is a powerful, state-of-the-art EAS monitor receiver in a compact half-rack package. It boasts three built-in unique receivers, each capable of AM, FM or NOAA reception. Each receiver sports a balanced monaural XLR audio output to serve as EAS monitor or on-air monitor throughout the broadcast facility. The 677 has an easy front panel setup with jog-wheel menu navigation and front panel readout. On the back panel, six

rear-panel GPOs may be user-assigned to alarm functions. Its dynamic Web interface provides control and monitoring remotely via any Web enabled device. It also offers remote listening by Web stream, as well as alarms/notification via email and SMS messages. SNMP is fully supported.

677 Three EAS monitor receivers in one List \$2,300.00 **\$2,070.00**



551

Precision FM and HD Radio Monitoring

The Inovonics 551 (3U) and 552 (1U) modulation monitors deliver precision monitoring of off-air analog FM and HD Radio signals remotely via front panel display (551) or any Web-enabled device (551 and 552). Both models decode FM and up to four HD signals simultaneously (so no extra options to purchase).

- Full-time off-air program audio available simultaneously as L/R-analog, AES3-digital and Dante-based AES67 AoIP streaming
- Collects histograms of signal parameters and displays HD Radio album artwork, station logos and more via front panel display (551) or remote Web interface (551 and 552)
- Spectrum graphs include RF Baseband, MPX and Left/Right audio; O-Scope views for MPS, Pilot, RDS and all audio channels

551 With LED meters and touch LCD List \$9,900.00 **\$8,910.00**
552-00 With minimal front panel display List \$8,800.00 **\$7,920.00**



552-00



Amazing AM Modulation Analyzer

The Inovonics 526 fourth-generation all-digital AM modulation monitor combines detailed DSP signal analysis with a menu-driven touchscreen display, plus Webserver-based total access for remote operation, including measurements, graphical data and direct Web-browser audio monitoring of the off-air program.

- Remotely tune AM band, read metering, peak flashers
- Tuning Range: 520kHz to 1720kHz in 10kHz steps; 522kHz to 1719kHz in 9kHz steps.
- Graphic 5-inch touchscreen and remote display of all level metering
- Station Rotation for round robin monitoring of up to 30 preset stations
- Remote control and monitoring via Web
- Enhanced alarm logging with notifications via Email/SMS and SNMP
- Remote listening with multi-user stream and Dante/AES67 AoIP

526 List \$6,000.00 **\$5,400.00**

Comprehensive RDS/RBDS is Easy with BSW



NEW

Dynamic RDS Encoding You Can Trust

The Inovonics INOmini 704 offers easy and reliable dynamic RDS text messaging at a budget-pleasing price. Compatible with all standard playout systems, it will identify your station by format, display your station's "street name", and continuously update artist and song title information as provided by the playout system through a network connection. An intuitive Web interface delivers comprehensive setup, programming and management.

- Quick-and-easy way to add a dynamic RDS/RBDS presence
- Scrolling-PS and Radio Text static messaging (up to 128 characters)
- LCD display
- Web interface for setup, programming, and management
- Encoder programming is easily confirmed on-site via LCD display
- Rapid data transfer allows scrolling messages to be updated in seconds
- May be used with any stereo-generator and exciter

704 List \$990.00 **\$891.00**

Inovonics' Web-Enabled SiteStreamer Series

- **INOmini 638:** FM/HD Radio remote signal monitor
- Sends instant error messages via email or SMS text
- **INOmini 637:** AM receiver for remote signal monitoring
- **INOmini 635:** FM receiver for remote signal monitoring
- Streams off-air audio or a wired audio feed back to any computer, tablet or mobile device

635 FM/RDS SiteStreamer List \$1,100.00 **\$990.00**
637-AM AM SiteStreamer List \$1,080.00 **\$972.00**
638 FM/HD Radio remote signal monitor List \$1,150.00 **\$1,035.00**



638



Magnificent All-Digital FM Modulation Monitor

The Inovonics Model 541 FM Modulation Monitor delivers a wealth of information about the transmitted signal, including RF carrier and all subcarriers, the audio component defining the technical quality that the listener hears, and full decoding of RDS data and SCA audio. It combines detailed DSP signal analysis with a menu-driven touchscreen display, plus Webserver-based total access for remote operation, including measurements, graphical data and direct Web-browser audio monitoring of the off-air program.

- Superb off-air reception of analog-FM broadcasts with highly-accurate displays of total modulation and other measurements
- Analog, AES3, HTTP/UDP Web-streaming and independent AoIP-streaming program audio outputs, plus an FM composite/MPX baseband output

541 List \$6,000.00 **\$5,400.00**



703-00

Affordable RDS/RBDS Presence

The Inovonics 703 INOmini encoder is a quick, inexpensive way to an RDS/RBDS presence, with easy USB programming using the supplied Windows software. It will identify your station by format, display your station's street name and continuously transmit station promos or advertising messages to your listeners. It can store your station's data in its non-volatile memory and can then be re-installed at the transmitter site.

703-00 List \$690.00 **\$621.00**
Accessories:
RK-00 Rack-mount kit **\$99.00**



RDS-SG5



RDS-SG6

Powerful RDS/RBDS Encoders

DEVA Broadcast's SmartGen 5 encoder supports all RDS applications in conformity with European CENELEC and United States NRSC standards and it is fully compatible with UECP EBU SPB490 Version 7.05. The interactive function RT+ for song tagging is also fully supported.

Based on the latest RDS technology, SmartGen 6 guarantees fully digital synthesis of the RDS signal. It's a cost-effective solution for sending of TMC, EWS Services and song tagging via the supported RT+ function.

RDS-SG5	List \$1,850.00	\$1,665.00
RDS-SG6	List \$2,250.00	\$2,025.00



NEW

Compact, Full Duplex IP Audio Codec

The DEVA Broadcast DB910 lets you send and receive audio at the same time, while guaranteeing fast and easy monitoring of the signal fed to the transmitter.

- Full duplex IP audio transmission
- Comprehensive control and easy setup via a standard web browser
- Analog audio I/O (4 x 1/4" phone jack connectors)
- Digital audio I/O (2 x 1/4" phone jack connectors)
- 6 x General Purpose Inputs and Outputs
- High quality HE-AAC (v.1 and v.2), MPEG-1 and MPEG-3 decoding
- Sample rate support up to 48 kHz
- Auto backup switching in the event of an audio loss
- Built-in MP3 Player

DB910	List \$1,250.00	\$1,125.00
-------	-----------------	-------------------

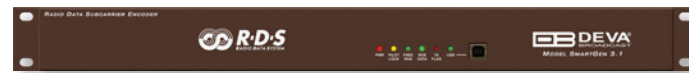

RDS-SG3.1

Workhorse RDS/RBDS Encoders

The DEVA Broadcast SmartGen 3.1 can transmit basic RDS information along with decoder information, music/speech flags, PS and radio text scrolling options. It offers a fully digital synthesis of the RDS signal and two types of operating modes: loop-through and side-chain.

- Works with any FM exciter and stereo generator
- Supports both RDS and RBDS standards
- Fully digital synthesis of RDS signal
- MPX loop-through and side-chain modes
- Internal or external pilot/MPX synchronization
- Built-in dedicated 19kHz source for internal sync
- USB programming interfaces
- Built-in failsafe bypass relay
- Intuitive Windows configuration software
- Easy installation and set up

RDS-SG31	List \$650.00	\$585.00
RDS-SG41	List \$1,295.00	\$1,165.50



RDS-SG4.1

The SmartGen 4.1 is a fully digital RDS/RBDS encoder that supports all service IDs and offers simultaneous scrolling PS and RadioText messaging. It's fully compatible with the latest UECP EBU SPB490 Version 7.05. The interactive function RT+ for song tagging is also fully supported.

- Works with any FM exciter and stereo generator
- Supports RT+ for songs and content tagging
- Supports TMC (Traffic Message Channel)
- Compatible with EWS (Emergency Warning System)
- Embedded WEB server for interactive supervision
- Fully digital synthesis of RDS signal
- Internal or external pilot/MPX synchronization
- MPX loop-through and side-chain modes
- Remote RDS viewer to visualize broadcasted data
- Interfaces with all popular radio automation systems
- SNTP for automatic synchronization of the built-in clock
- Real time clock schedules for scrolling text and text lists



More online! Scan for full specs.



Smart RDS/RBDS Encoder

The DEVA Broadcast SmartGen Mini's USB and LAN connectivity lets you program its non-volatile memory using any PC and the supplied Windows software.

- Compact chassis: 4.72" x 4.06" x 1.2"
- Works with any FM exciter and stereo generator
- Supports RT+ for songs and content tagging
- Supports TMC (Traffic Message Channel)
- Compatible with EWS (Emergency Warning System)
- Embedded WEB server for interactive supervision
- Fully digital synthesis of RDS signal

RDS-MINI	List \$850.00	\$795.00
----------	---------------	-----------------

Stay on Top of Things with BSW



Full-Featured FM/HD Radio/IP Audio Confidence Monitoring Receiver

The DEVA DB3011 offers brilliant acoustic characteristics with extensive feature set. The high-selective DSP-based tuner of the device allows the HD Radio, FM and Internet stream of the station to be selected, monitored and listened to. It not only allows you to constantly monitor the sound of your station, but will also measure and store for future analysis the RF level and Left & Right Audio Levels.

DB3011	HD confidence monitor	List \$2,350.00	\$2,232.50
--------	-----------------------	-----------------	-------------------



Ultra-Versatile Modulation Monitor

The Belar FMCS-1 modulation monitor can handle FM RF carrier measurements, AM and Sync AM noise measurements, variable BW digital IF and composite filtering. It also delivers RDS injection/phase and full data decoding along with peak and RMS measurements. It boasts an RJ-45 connector to link to the internet for remote monitoring, and a headphone output for local monitoring.

FMCS-1		List \$7,695.00*
--------	--	------------------

*Prices too low to advertise. Call BSW for the lowest price 1-800-426-8434.



HD (and More) Modulation Monitor

Equip your station for years to come with this state-of-the-art HD radio monitor. The Belar FMHD-1 will effortlessly decode HD radio signals and analog FM signals simultaneously, displaying HD radio status, data, time alignment, and configuration information, as well as audio metering and RF and audio spectrums.

FMHD1	FM HD Radio mod monitor	List \$7,895.00*
-------	-------------------------	------------------



Versatile Modulation Monitors

Belar's FMM-2 is a wideband, FM monitor that measures the total modulation characteristics of monaural as well as multiplexed FM transmitters.

*Prices too low to advertise. Call BSW for the lowest price 1-800-426-8434.

FMM2	FM modulation monitor	List \$3,595.00*
FMS2	FM stereo mod monitor	List \$4,995.00
FMM4A	FM frequency monitor	List \$2,695.00
SCMA1	SCA modulation analyzer	List \$3,995.00
AMDA1	AM distribution amp	List \$1,195.00



More online! Scan for full specs.



Ultra-Compact RDS/RBDS Encoder

The cost-effective DEVA Broadcast SmartGen Micro can transmit all basic RDS information along with decoder information and music/speech flags.

- Compact chassis: 4.72" x 4.06" x 1.2"
- Works with any FM exciter and stereo generator
- Supports both RDS and RBDS standards
- Fully digital synthesis of RDS signal
- MPX loop-through and side-chain modes
- Internal or external pilot/MPX synchronization
- Built-in dedicated 19kHz source for internal sync
- USB programming interfaces

RDS-SG41	List \$525.00	\$472.50
----------	---------------	-----------------



Cutting Edge Digital Modulation Monitors

The Belar FMMA-1 Wizard is a microprocessor controlled, digital baseband FM modulation monitor/analyzer that precisely measures peak modulation, peaks per minute, average peak modulation, modulation density and more.

The FMSA-1 digitizes the composite baseband signal and decodes the stereo multiplex portion using digital signal processing techniques.

FMMA1	Modulation Monitor	List \$4,495.00*
FMSA1	DSP-based Modulation Monitor	List \$4,995.00

*Prices too low to advertise. Call BSW for the lowest price 1-800-426-8434.



Precision AM Frequency Monitor

The Belar AMM-4 is a digital AM frequency monitor designed especially for automatic broadcast transmitter monitoring. It accurately monitors any frequency from 10 kHz to 50 MHz. Its front panel LED indicator will warn of low RF level or loss of carrier.

- ±10 Hz and ±20 Hz off-frequency alarms
- RF level, invalid count and count inhibit alarms
- External timebase input, 1 MHz output

AMM4	AM freq monitor	List \$2,395.00*
LP1	Shielded AM loop antenna	List \$625.00
LP1A	Shielded antenna w/ preamp	List \$750.00

*Prices too low to advertise. Call BSW for the lowest price 1-800-426-8434.



Effortlessly Manage Alerts With VIAVI and BSW

BSW
CUSTOMER
FAVORITE



More online!
Scan for full specs.



EASYCAP-B4030



One-Box Solution for Audio/Video Alerts

The Viavi EASyCAP Encoder/Decoder has everything you need to deliver audio and video alerts, such as EAS, CAP, local access messages, audio/video peripherals, control over serial and network based devices, interfaces for network management systems as well as network protocols and interfaces.

- One-box integrated solution
- Flexible and expandable open architecture
- IP-based alerting protocols
- Ethernet support for remote network control
- CAP IPAWS
- 2 RU chassis with 3.5" color touch-screen LCD
- Two RS-232 serial ports, four USB ports, two Ethernet ports
- Six balanced 600 ohm audio inputs for EAS monitoring
- NTSC video character generator

EASYCAP-B4030	EASyCAP for TV Broadcasters W 3 Internal AM/FM/NOAA Radios	List \$3,495.00
EASYCAP-MPEG-LIC	License Key for one (1) EASyCAP unit that enables the MPEG-2/MPEG-4 streaming output	List \$995.00
EASYCAP-NETWORK-LIC	License Key for one (1) EASyCAP unit that enables the Network Management feature	List \$995.00
EASYCAP-CUSTOM-LIC	License Key for one (1) EASyCAP unit that enables the custom messaging software feature	List \$595.00
EASYCAP-COMPLIANCE-LIC	License Key for one (1) EASyPLUS or EASyCAP unit that enables the Compliance Assistant feature	List \$495.00

*Prices too low to advertise. Call BSW for the lowest price 1-800-426-8434.

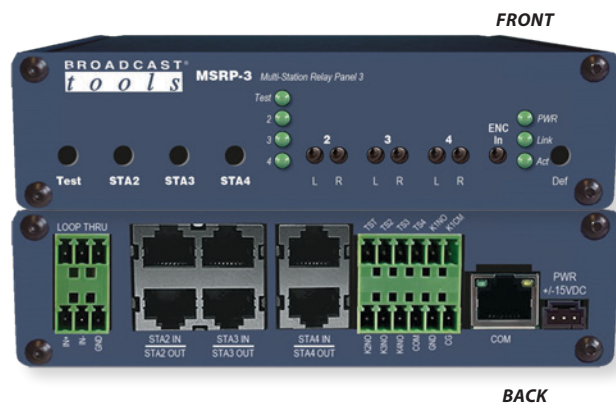

FRONT

Elegant EAS Relay/Switcher

Broadcast Tools' MSRP-3 provides additional alert audio distribution and transparent audio interrupt switching for the Sage ENDEC. Together with the single balanced stereo switched audio interrupt relay built into the ENDEC, the MSRP-3 will deliver interrupt switching for four stereo audio paths. Standard pinout RJ45 station audio input and output jacks make installation with Cat5 or Cat6 patch cables plug and play. The encoder audio input is an unbalanced monoaural RCA jack, eliminating the need for external level conversion.

MSRP-3	Three Station Analog EAS Relay	List \$629.00	\$597.55
MSRP-3-ETHERNET	Three Station Analog EAS Relay with Ethernet Option (MSRP-3 Net)	List \$659.00	\$629.00



BSW
CUSTOMER
FAVORITE

Feature-packed and cost-effective! **SAGE Alerting Systems**

Proven EAS Encoder/Decoder

The Sage Digital ENDEC offers an internal AES/EBU interface, LAN support, and a Web Browser-based interface to support a new generation of EAS users. While the Digital ENDEC continues to support Radio, TV and Cable users, it also supports the first responder and state/county/local emergency centers with emerging standards such as IPAWS and CAP. Future-proof, it is designed to be ready for future revisions to the EAS system. Accessories include Pro and Lite versions of Emergency Management Software, a relay panel to control up to 3 additional stations from a single ENDEC and a remote control to activate functions within the ENDEC system.

- 6 audio inputs; 6 serial ports
- Encoder and Microphone input
- 4x20 LCD display
- Internal speaker and Line Out
- Four contact closures; five GPIO inputs
- Web-Based control; 10/100 Base-T LAN support
- 2 USB connectors for printers, additional serial ports, future expansion
- AES/EBU Digital Audio Interrupt with active switching
- 64 MByte onboard storage for log files

DIGITALENDEC	EAS Encoder/Decoder	List \$2,895.00*
---------------------	---------------------	------------------

Accessories:

RM-1	Rack mount for ENDEC-RP2	List \$89.00
-------------	--------------------------	--------------

*Prices too low to advertise. Call BSW for the lowest price 1-800-426-8434.

The Best EAS Technology is at BSW

BSW
CUSTOMER
FAVORITE



More online!
Scan for full specs.



DASDEC-III



New Emergency Messaging Solutions from Digital Alert Systems

Digital Alert Systems' DASDEC-III covers all current EAS requirements and is designed to handle future needs with easy software upgrades in a flexible, proven hardware package boasting a host of communication interfaces and standards. You can choose from two base hardware models and customize to fit your specific needs. Call BSW to get the configuration that's right for you.

The DAS3-2RADIO license key module for the DAS3-EL gives you dual (2) tri-band radio receivers for AM, FM, or WX (NOAA). The DAS3-3RADIO license key module for the DAS3-EX provides triple (3) tri-band radio receivers AM, FM, or WX (NOAA).

The DAS3-AES is a factory-installed AES digital audio expansion module for DASDEC-III models only. It activates a separate AES program audio loop with power-off bypass.

The following factory-installed expansion modules work with the DAS3-EX and DASDEC-II (/4, and /5 models only): EXP-GPIO-E offers expanded GPIO (10 inputs and 10 outputs). EXP-EAS-E provides expanded EAS decoder audio inputs (two extra analog mono audio input channels). EXP-2NICGIG delivers dual port Gig-E expansion, providing a total of three unique Ethernet NICs.

DAS3-EL	Entry Level Emergency Messaging Platform, FCC Certified EAS/CAP Decoder-Only	List \$2,195.00 *
DAS3-EL-WARS	Extends Standard DAS3-EL 2-Year Warranty to 5-Years	List \$330.00
DAS3-EX	Expandable Emergency Messaging Platform, FCC Certified EAS/CAP Encoder/Decoder	List \$3,395.00
DAS3-EX-WARS	Extends Standard DAS3-EX 2-Year Warranty to 5-Years	List \$510.00
DAS3-CX	Cable eXpansion Messaging Platform, FCC Certified Encoder/ Decoder platform	List \$4,990.00
DAS3-CX-WARS	Extends Standard DAS3-CX 2-Year Warranty to 5-Years	List \$750.00
DAS3-GX	Grouped eXpansion Messaging Platform, FCC Certified Encoder/ Decoder platform	List \$5,440.00
DAS3-GX-WARS	Extends Standard DAS3-GX 2-Year Warranty to 5-Years	List \$815.00
DAS3-2RADIO	Dual (2) tri-band radio receivers AM, FM, or WX (NOAA) license key module for DAS3-EL	List \$600.00
DAS3-3RADIO	Triple (3) tri-band radio receivers AM, FM, or WX (NOAA) license key module for DAS3-EX	List \$750.00
DAS3-AES	AES digital audio expansion module for DASDEC-III	List \$450.00
R194	Composite (NTSC) CG and stereo audio switch	List \$4,595.00
R194P	8-channel composite (PAL) CG and stereo audio switch	List \$4,595.00
R177M	Master baseband switch, 1x8 stereo A/V DA & eight ganged 2x1 A/V switches	List \$1,595.00
R165A	Audio/Video switch	List \$1,495.00
EXP-GPIO-E	Expanded GPIO 10 Inputs and 10 Outputs	List \$795.00
XBOB-4	Analog NTSC video EAS text crawl system	List \$650.00
RF-PRO-1B	External amplified AM radio antenna	List \$1,031.25
R164	Stereo audio/video switch	List \$495.00
EXP-2NICGIG	Dual port Gig-E expansion for DAS3-EX and DASDEC-II	List \$395.00
DASENCS	DASDEC One-Net encoder software	List \$400.00
EXP-EAS-E	Expanded EAS decoder audio Inputs	List \$395.00
USB-4RS232	USB to 4 Serial Port expander, provides four (4) additional RS-232 serial ports	List \$350.00
J55-FM	External FM (88-108MHz) horizontal 5-element Yagi radio antenna	List \$450.67
627A	Stereo Audio/Video external switch module	List \$395.00
J56-162	External 162MHz NOAA (WX) vertical 5-element Yagi radio antenna	List \$295.00
USB-1NICGIG	Single Port USB to Gigabit ethernet expansion	List \$100.00
AL-FFFF-9	75 Ohm F-Female to F-Female gas discharge tube lightning suppression	List \$65.00

*Prices too low to advertise. Call BSW for the lowest price 1-800-426-8434.

Upgrade Your Broadcast Antennas



BSW
CUSTOMER
FAVORITE

BKP180-HD

Versatile NiCOM FM Antennas

NiCOM FM antennas are available in broadband, narrow band and 900 MHz (for STL applications). Proudly built in the USA, they offer rugged reliability with a three-year warranty.

The BKP120 is a folded edge anodized aluminum parabolic antenna. Because of its high directivity and gain, it's ideal for long distance STL links. The BKG1/P broadband dipole antenna is constructed of stainless steel and is designed to last a long time in any weather condition. Because of its sturdy construction, it can support up to 2.5 kW of input power with the appropriate connector. Call or visit our website for full details.

Type	Model #	Band Type	List Price	Max input power
Parabolic	BKP120	900 MHz	\$535.00*	100 Watts
Parabolic	BKP120-HD	900 MHz	\$760.00	100 Watts
Dipole	BKG1P	Broadband	\$590.00	2.5 kW
Parabolic	BKP180-HD	900 MHz	\$1,240.00	100 Watts
Circular	BKG77	Broadband	\$760.00	1 kW
Circular	BKG88	Narrow Band	\$420.00	500 Watts

*Prices too low to advertise. Call BSW for the lowest price 1-800-426-8434.



FOR A LOW PRICE QUOTE WITH NO HANG-UPS, CALL BSW! 800.426.8434



BKG77

Antennas You Can Count On

NiCOM BKG and BKY series FM antennas boast sturdy stainless steel construction for long life in even the most extreme weather conditions. Call us to find the best configuration for your particular needs.

BKG1P	Broadband portable dipole, 1 kW	List \$690.00*
BKG1P-F	With 7/8 connector, 2 kW	List \$830.00
BKG1P-M	With 7/16 connector, 2 kW	List \$790.00
BKG77	Broadband circular, 1 kW	List \$899.00
BKG77F	With 7/8 connector, 2 kW	List \$999.00
BKG77-M	With 7/16 connector, 2 kW	List \$949.00
BKG88	Narrowband circular, 500 W	List \$650.00
BKY3P	Broadband 3-element, 1 kW	List \$890.00

*Prices too low to advertise. Call BSW for the lowest price 1-800-426-8434.



Rugged Power Dividers

NiCOM BAC series power dividers smoothly divide power equally from the transmitter to all antennas connected to it. They are available in different versions depending on the power input and I/O types needed. Constructed of brass, with internal silver-plated lines and teflon insulators, these rugged units are built for high performance and built to last.

- 3-output and 4-output versions (other versions available)
- Impedance: 50 Ohms
- VSWR: 1.05:1
- Frequency bandwidth: 15 MHz
- Max power input: BAC3N: 1 kW; BAC3L: 2 kW; BAC4N: 1 kW; BAC4L: 2 kW; BAC4FL: 5 kW

Other power input options available (call BSW).

BAC3L	One 7/8 input, three N outputs	List \$740.00*
BAC3N	One N input, three N outputs	List \$640.00
BAC4FL	One 7/8 input, four 7/16 outputs	List \$810.00
BAC4L	One 7/8 input, four N outputs	List \$750.00
BAC4N	One N input, four N outputs	List \$650.00

*Prices too low to advertise. Call BSW for the lowest price 1-800-426-8434.

BSW is Your Antenna Connection



PR950



HDCA-10-HCM



Premium Kathrein-Scala Antennas

Kathrein-Scala antennas are designed for professional FM transmit and receive applications as well as control station, point-to-point, and SCADA applications. These antennas are made with premium materials using state of the art electrical and mechanical designs resulting in superior performance and long service life. Call, email or visit BSWUSA.com for more information on our wide selection of state-of-the-art Kathrein-Scala antennas.

- Heavy duty aluminum castings and stainless steel hardware
- State-of-the-art electrical and mechanical designs
- Superior performance
- Long service life
- Models to meet every need
- Professional FM transmit and receive applications
- Control station, point-to-point, and SCADA applications
- Vertical, horizontal polarization options
- Center-mount, rear-mount options
- Gain, frequency range, impedance options



CA7-460



YA7FMLURM

Scan for more information.



CALL BSW TO CONFIGURE YOUR ANTENNA AND GET THE BEST PRICING HUMANLY POSSIBLE! 800.426.8434

HDCA-5-HCM	FM yagi, 88-108 MHz, center-mount, 75 ohms	List \$1,388.00*
HDCA-10-HCM	FM yagi, 88-108 MHz, center-mount, 75 ohms	List \$2,074.00
YA7-155	Broadband dipole Yagi, 150-164 MHz, 50 ohms	List \$1,171.00
YA7-FMH-HCM	FM yagi, 98-108 MHz, center-mount, 50 ohms	List \$1,326.00
YA7FMHURM	FM yagi, 98-108 MHz, rear-mount, 50 ohms	List \$1,485.00
YA7FMLURM	FM yagi, 88-98 MHz, rear-mount, 50 ohms	List \$1,499.00
YA7FMLHCM	FM yagi, 88-98 MHz, center-mount, 50 ohms	List \$1,340.00
CLFMHRM75	FM log-periodic, 88-108 MHz, 75 ohms	List \$2,116.00
CLFMVRM50N	FM log-periodic, 88-108 MHz, 50 ohms	List \$2,377.00
PR950	Paraflector, 940-960 MHz, 50 ohms	List \$1,953.00
FMVMP	FM dipole, 88-108 MHz, 50 ohms	List \$883.00
CA7-460	Broadband yagi, 450-470 MHz, 50 ohms	List \$678.00
TY900	Broadband yagi, 890-960 MHz, 50 ohms	List \$302.00
MF950B	Broadband, half-parabolic, 940-960 MHz, 50 ohms	List \$1,031.00
MKPx2	Antenna mounting kit for MF90B	List \$61.00

*Prices too low to advertise. Call BSW for the lowest price 1-800-426-8434.

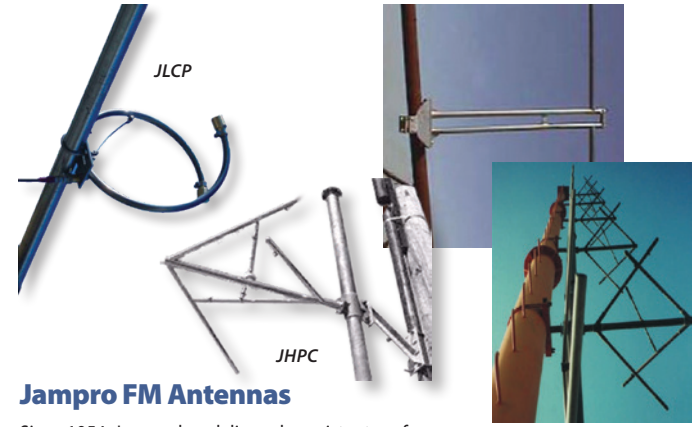

Jampro FM Antennas

Since 1954, Jampro has delivered consistent performance and quality based on rock-solid engineering. Today, over 15,000 broadcasters worldwide benefit from Jampro systems, and BSW is the number one source for Jampro antennas.

Circularly Polarized Low Power FM Antennas (may also be used for translators)

The JLCP is designed specifically for omni-directional low power applications such as LPPM, Translator and Booster stations.



# Bays	Model #	Input Connector	List Price	Max input power
1	JLCP-1	Type "N"	\$915.00*	500 Watts
2	JLCP-2	Type "N"	\$2,010.00	500 Watts
2	JLCP-2-1KW	7/8" EIA	\$2,995.00	1 kW
2	JLCP-2-2KW	7/8" EIA	\$3,445.00	2 kW
3	JLCP-3	7/8" EIA	\$4,185.00	1 kW
3	JLCP-3-2KW	7/8" EIA	\$5,845.00	2 kW
4	JLCP-4	Type "N"	\$4,015.00	500 Watts
4	JLCP-4-1KW	7/8" EIA	\$5,000.00	1 kW
4	JLCP-4-2KW	7/8" EIA	\$5,900.00	2 kW

*Prices too low to advertise. Call BSW for the lowest price 1-800-426-8434.

Vertically Polarized Low Power FM Antennas: Available in configurations up to 8 bays. Contact BSW for more details.

The JLVP is a low power antenna designed specifically for omni-directional translator/booster applications.

# Bays	Model #	Input Connector	List Price	Max input power
1	JLVP-1	Type "N"	\$955.00*	500 Watts
1	JLVP-1-1KW	7/8" EIA	\$1,325.00	1 kW
2	JLVP-2	Type "N"	\$1,785.00	500 Watts
2	JLVP-2-1KW	7/8" EIA	\$2,740.00	1 kW
4	JLVP-4	Type "N"	\$4,165.00	500 Watts
4	JLVP-4-1KW	7/8" EIA	\$5,150.00	1 kW

*Prices too low to advertise. Call BSW for the lowest price 1-800-426-8434.

Circularly Polarized Medium Power FM Antennas: Radomes and configurations up to 12 bays available. Contact BSW for more details.

The JMPC antenna is the medium power version of the acclaimed PENETRATOR antenna, which has become an industry standard for quality and performance.

# Bays	Model #	Input Connector	List Price	Max input power
1	JMPC-1	1-5/8" EIA female	\$3,595.00*	10 kW
2	JMPC-2	1-5/8" EIA female	\$5,184.00	10 kW
3	JMPC-3	1-5/8" EIA female	\$7,745.00	10 kW
4	JMPC-4	1-5/8" EIA female	\$10,365.00	10 kW

*Prices too low to advertise. Call BSW for the lowest price 1-800-426-8434.

Circularly Polarized High Power Antennas

The JAMPRO JHPC antenna is the high power version of the industry-standard PENETRATOR antenna, offering exceptional performance and rugged design.

# Bays	Model #	Power Gain	List Price	Max input power
1	JHPC-1	0.46	\$5,140.00*	10 kW
2	JHPC-2	1.00	\$8,240.00	20 kW
3	JHPC-3	1.5	\$11,325.00	25 kW
4	JHPC-4	2.1	\$14,865.00	35 kW

*Prices too low to advertise. Call BSW for the lowest price 1-800-426-8434.



Superior VSWR bandwidth!

ERI FM Antennas

For more than 65 years, ERI has served the broadcast industry with products of the highest quality and dependability. BSW is proud to offer a wide line of ERI antennas to meet your broadcast needs.

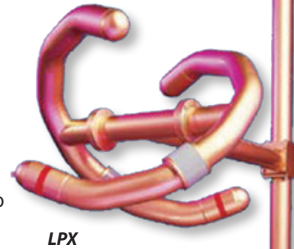

LPX

Low Power FM Antennas (1 - 4 bays)

The 100A Series antenna is the latest development in ERI's famous ROTOTILLER® style FM antenna. The 100A Series antenna is designed for non-pressurized, translator and low power FM applications. This antenna is also available in half wavelength bay-to-bay configurations, which will limit RFI problems by reducing downward and upward radiation.

Mounting brackets and attachment hardware suitable for round members up to 4" diameter are included. Stand-off pole mounting brackets and antenna input jumper cables are also available. Contact BSW for your specific application.

# Bays	Model #	Input Connector	List Price	Max input power
1	100A-1M	7-16 DIN Male	\$1,868.00*	1000 watts
2	100A-2F	7-16 DIN female	\$3,621.00	2000 watts
4	100A-4F	7-16 DIN female	\$7,127.00	2000 watts
2	100A-2F-HW	7-16 DIN female	\$3,621.00	2000 watts
4	100A-4F-HW	7-16 DIN female	\$7,127.00	2000 watts

*Prices too low to advertise. Call BSW for the lowest price 1-800-426-8434.

Medium Power FM Antennas (1 - 4 bays)

ERI is the only manufacturer to use large diameter outer conductors and a completely enclosed, pressurized, internal series feed system. The result is a simple and reliable method of coupling power to the elements. Unlike competing designs, ERI series fed antennas do not require a troublesome secondary current loop for element excitation with all the resulting disadvantages. All ERI antennas include brackets for mounting on leg, pole, or face mounting (up to 42-inch uniform cross section tower); brackets for other mounting configurations are optionally available. Contact BSW for your specific application.

# Bays	Model #	Input Connector	List Price	Max input power
1	LPX-1E	1-5/8-inch EIA female	\$4,252.00*	9 kW
2	LPX-2C	3-1/8-inch EIA female	\$9,567.00	12 kW
3	LPX-3E	1-5/8-inch EIA female	\$10,378.00	9 kW
3	LPX-3C	3-1/8-inch EIA female	\$12,630.00	12 kW
4	LPX-4E	1-5/8-inch EIA female	\$13,441.00	9 kW
4	LPX-4C	3-1/8-inch EIA female	\$15,693.00	12 kW
2	LPX-2E-HW	1-5/8-inch EIA female	\$7,315.00	9 kW
2	LPX-2C-HW	3-1/8-inch EIA female	\$9,567.00	12 kW
3	LPX-3E-HW	1-5/8-inch EIA female	\$10,378.00	9 kW
3	LPX-3C-HW	3-1/8-inch EIA female	\$12,630.00	12 kW

*Prices too low to advertise. Call BSW for the lowest price 1-800-426-8434.



Shively Antenna Systems

Celebrating fifty seven years of leadership in broadcast antenna system design and optimization. Our record with the FCC and regulatory agencies around the world is unsurpassed. We can operate throughout the RF spectrum, but FM is our passion.

SF-M-1E	1 bay End Fed SF FM antenna system	List—\$8,610.00*
SF-M-2E	2 bay End Fed SF FM antenna system	List—\$13,400.00
SF-M-2C	2 bay Center Fed SF FM antenna system	List—\$13,650.00
SF-M-2E-HW	2 bay Half Wave End Fed SF FM antenna system	List—\$13,400.00
SF-M-2C-HW	2 bay Half Wave Center Fed SF FM antenna system	List—\$13,400.00
SF-M-3E	3 bay End Fed SF FM antenna system	List—\$16,890.00
SF-M-3C	3 bay Center Fed SF FM antenna system	List—\$17,250.00
SF-M-3E-HW	3 bay Half Wave End Fed SF FM antenna system	List—\$16,890.00
SF-M-3C-HW	3 bay Half Wave Center Fed SF FM antenna system	List—\$17,250.00
SF-M-4E	4 bay End Fed SF FM antenna system	List—\$22,950.00
SF-M-4C	4 bay Center Fed SF FM antenna system	List—\$23,450.00
SF-M-4E-HW	4 bay Half Wave End Fed SF FM antenna system	List—\$23,450.00
SF-M-4C-HW	4 bay Half Wave Center Fed SF FM antenna system	List—\$23,450.00
SF-M-5E	5 bay End Fed SF FM antenna system	List—\$28,200.00
SF-M-5C	5 bay Center Fed SF FM antenna system	List—\$29,450.00
SF-M-5E-HW	5 bay Half Wave End Fed SF FM antenna system	List—\$28,200.00
SF-M-5C-HW	5 bay Half Wave Center Fed SF FM antenna system	List—\$29,450.00
SF-M-6C	6 bay Center Fed SF FM antenna system	List—\$34,450.00
SF-M-6C-HW	6 bay Half Wave Center Fed SF FM antenna system	List—\$34,450.00
SF-M-7C	7 bay Center Fed SF FM antenna system	List—\$37,450.00
SF-M-7C-HW	7 bay Half Wave Center Fed SF FM antenna system	List—\$37,450.00
SF-M-8C	8 bay Center Fed SF FM antenna system	List—\$43,910.00
SF-M-8C-HW	8 bay Half Wave Center Fed SF FM antenna system	List—\$43,910.00
SF-M-9C	9 bay Center Fed SF FM antenna system	List—\$48,650.00
SF-M-9C-HW	9 bay Half Wave Center Fed SF FM antenna system	List—\$48,650.00
SF-M-10C	10 bay Center Fed SF FM antenna system	List—\$53,450.00
SF-M-10C-HW	10 bay Half Wave Center Fed SF FM antenna system	List—\$53,450.00
SF-M-11C	11 bay Center Fed SF FM antenna system	List—\$59,450.00
SF-M-11C-HW	11 bay Half Wave Center Fed SF FM antenna system	List—\$59,450.00
SF-M-12C	12 bay Center Fed SF FM antenna system	List—\$63,500.00
SF-M-12C-HW	12 bay Half Wave Center Fed SF FM antenna system	List—\$63,500.00
SF-HP-1E	1 bay End Fed SF FM Antenna antenna system	List—\$9,567.00
SF-HP-2E	2 bay End Fed SF FM antenna system	List—\$14,889.00
SF-HP-2C	2 bay Center Fed SF FM antenna system	List—\$15,167.00
SF-HP-2E-HW	2 bay Half Wave End Fed SF FM antenna system	List—\$14,889.00
SF-HP-2C-HW	2 bay Half Wave Center Fed SF FM antenna system	List—\$14,889.00
SF-HP-3E	3 bay End Fed SF FM antenna system	List—\$18,767.00
SF-HP-3C	3 bay Center Fed SF FM antenna system	List—\$19,167.00
SF-HP-3E-HW	3 bay Half Wave End Fed SF FM antenna system	List—\$18,767.00
SF-HP-3C-HW	3 bay Half Wave Center Fed SF FM antenna system	List—\$19,167.00
SF-HP-4E	4 bay End Fed SF FM antenna system	List—\$25,500.00
SF-HP-4C	4 bay Center Fed SF FM antenna system	List—\$26,056.00
SF-HP-4E-HW	4 bay Half Wave End Fed SF FM antenna system	List—\$25,500.00
SF-HP-4C-HW	4 bay Half Wave Center Fed SF FM antenna system	List—\$26,056.00
SF-HP-5E	5 bay End Fed SF FM antenna system	List—\$31,333.00
SF-HP-5C	5 bay Center Fed SF FM antenna system	List—\$32,722.00
SF-HP-5E-HW	5 bay Half Wave End Fed SF FM antenna system	List—\$31,333.00
SF-HP-5C-HW	5 bay Half Wave Center Fed SF FM antenna system	List—\$32,722.00
SF-HP-6C	6 bay Center Fed SF FM antenna system	List—\$38,278.00
SF-HP-6C-HW	6 bay Half Wave Center Fed SF FM antenna system	List—\$38,278.00
SF-HP-7C	7 bay Center Fed SF FM antenna system	List—\$41,611.00
SF-HP-7C-HW	7 bay Half Wave Center Fed SF FM antenna system	List—\$40,789.00
SF-HP-8C	8 bay Center Fed SF FM antenna system	List—\$48,789.00
SF-HP-8C-HW	8 bay Half Wave Center Fed SF FM antenna system	List—\$48,789.00
SF-HP-9C	9 bay Center Fed SF FM antenna system	List—\$54,056.00
SF-HP-9C-HW	9 bay Half Wave Center Fed SF FM antenna system	List—\$54,056.00
SF-HP-10C	10 bay Center Fed SF FM antenna system	List—\$59,389.00
SF-HP-10C-HW	10 bay Half Wave Center Fed SF FM antenna system	List—\$59,389.00
SF-HP-11C	11 bay Center Fed SF FM antenna system	List—\$66,056.00
SF-HP-11C-HW	11 bay Half Wave Center Fed SF FM antenna system	List—\$66,056.00
SF-HP-12C	12 bay Center Fed SF FM antenna system	List—\$70,556.00
SF-HP-12C-HW	12 bay Half Wave Center Fed SF FM antenna system	List—\$70,556.00
FM-IV-CP-1	1 bay IV-CP antenna system	List—\$2,460.00
FM-IV-CP-2	2 bay IV-CP antenna system	List—\$6,300.00
FM-IV-CP-3	3 bay IV-CP antenna system	List—\$8,795.00
FM-IV-CP-4	4 bay IV-CP antenna system	List—\$15,255.00
FM-IV-CP-5	5 bay IV-CP antenna system	List—\$15,950.00
FM-IV-CP-6	6 bay IV-CP antenna system	List—\$16,175.00

*Prices too low to advertise. Call BSW for the lowest price 1-800-426-8434.

Get the Job done Right

BSW
CUSTOMER
FAVORITE



AARON-655

Reliable Rebroadcast Receivers

These Inovonics rebroadcast receivers are designed to handle the most challenging reception scenarios. AARON 655 will always return to the programmed frequency and reception mode following a power interruption. AARON 650 offers composite pass-through and baseband regeneration modes. AARON 640 is a budget-friendly version.

- **AARON 655:** rebroadcasts FM and HD1- HD8; supports analog, AES-digital and streaming program inputs; RDS encoder passes or regenerates incoming RDS. Superior sensitivity, selectivity, and RF shielding
- **AARON 650:** rebroadcasts FM; state-of-the-art DSP-based receiver performance
- **AARON 640:** rebroadcasts FM; decodes entire analog baseband

AARON-655	List \$2,900.00	\$2,610.00
AARON-650	List \$2,800.00	\$2,520.00
AARON-640	List \$2,600.00	\$2,340.00

BSW IS THE SOURCE FOR INOVONICS GEAR. CALL TODAY! 800.426.8434



611



662

Feature-Rich Streaming Monitor

The Inovonics 611 delivers uninterrupted monitoring of online internet radio and other streaming applications, offering plenty of processing power and advanced functionality. It features balanced analog and AES-digital outputs as well as self-logging alarms that constantly check for audio loss, stream loss and Internet loss. The Web-enabled 662 DAB/DAB+ SiteStreamer provides comprehensive remote audio monitoring via the Internet.

- Support for HTTP and HTTPS streams
- Stream formats: Icecast/Shoutcast, HLS (Ras, MPEG-TS, fMP4)
- Can rotate through preset streams sequentially, monitoring one stream at a time
- Failover support: preset back-up streams with customizable failover triggers
- Adjustable output levels for Analog L/R and AES-digital
- Alarms and notifications via email or SMS for audio loss, stream loss, internet loss

611	Internet audio streaming monitor	List \$51,900.00	\$1,710.00
662	Remote audio monitor	List \$1,150.00	\$1,035.00
RK-00	Custom 1U 19" rack shelf	List \$110.00	\$99.00



RK-00

BSW is Your Best Connection to Broadcast Tools



NEW

DTD16PLUS-G2NET



NEW

DTMF Decoders with USB and More

The DTD-16 + G2 is a loaded, user programmable DTMF tone/sequence decoder that decodes single tones or sequences up to six tones in length, which can be assigned to any one of eight SPST normally open relays, eight open collectors and the USB/RS-232 serial ports. The DTD-16 + G2 NET adds handy USB/RS-232 serial/Ethernet ports.

DTD16PLUS-G2NET	List \$399.00	\$379.05
DTD16PLUS-G2	List \$369.00	\$350.55

Four Channel Smart GPIO Converter

The Smart Relay 4 G2 provides four independent GPIO interfaces in one box, each equipped with two optically isolated inputs (wet or dry) and a 2PDT relay output. Features include: Independent user programmable Boolean logic and pulse stretching (delays) from 50ms to 99 hours, 59 minutes, 59.99 seconds.

SMARTRELAY4-G2	List \$319.00	\$303.05
----------------	---------------	-----------------

Top-Notch Passive Switcher/Router

Broadcast Tool's Universal 4.1 MLR Web is a web-based four input, one output switcher/router designed to pass AES or stereo balanced signals. Compatible with mobile and desktop web browsers. Features email alarm and SNMP capability.

- Front panel channel selection push buttons with active channel LED indicators
- Contact closure remote control and Web/TCP control

UNIVERSAL4.1-MLR-WEB	Web/TCP control	List \$749.00	\$711.55
----------------------	-----------------	---------------	-----------------



More online!
Scan for full specs.

Whatever the job, BSW has the tools you need to switch without a hitch!

8X2 Active Stereo Matrix Switcher

The ACS 8.2 PLUS cleanly provides matrix audio switching of 8 stereo inputs to 2 stereo plus 2 mono outputs. You can assign any or all inputs to any or all outputs, with any input assigned to output one having fading capabilities.

ACS8.2PLUS	List \$1,439.00	\$1,367.05
------------	-----------------	-------------------



- True matrix switching
- Logic functions via microprocessor and non-volatile memory
- Internal stereo silence sensors monitor both output channels
- Front panel input selection switches

Transparent 8x1 Stereo Routing Switcher

The Broadcast Tools SS 8.1 MLR is an eight input, single output switcher/router with mechanical latching relays. It's ideal for all types of passive signal switching controlled via front panel switches, contact closures and/or multi-drop RS-232 serial. It can route a signal in either direction and will keep routing signals even after losing power. Inputs may be balanced or unbalanced, while output levels, impedance, distortion, noise and balancing will match that of the selected input.

SS8.1MLR	List \$809.00	\$768.55
SS8.1MLR-RJ	List \$809.00	\$768.55



SS8.1MLR

- Front panel channel selection push buttons with active channel LED indicators
- Audio MUTE function allows user to turn off all audio
- Audio/signal switching via sealed mechanical latching relays
- Internal silence sensor with front panel LED indicator
- Fully RFI proofed



8x4 Analog Matrix Switcher

The ACS 8.4 G2 provides matrix audio switching of 8 stereo inputs to 4 stereo outputs. Matrix switching allows any/or all inputs to be assigned to any/or all outputs. Control via front panel push-button controls, contact closures, open collectors, logic, multi-drop RS-232 serial and/or TCP/UDP Ethernet commands. Installation is simplified with RJ45 audio jacks for input and output connections and plug-in euroblock screw terminal connectors for expansion and remote control.

ACS8.4-G2	List \$1,849.00	\$1,756.55
-----------	-----------------	-------------------

*Prices too low to advertise. Call BSW for the lowest price 1-800-426-8434.



Handy Helper from Broadcast Tools

- Built-in web server, web-based notification, monitoring, configuration, and control
- Front panel, remote, and web-based switcher controls.
- AES inputs feature silence sensors/phase monitors with front panel activity and alarm LED indicators.
- Silence trip level detection from -12dB to -35dB in 1 dB steps for each stereo channel

AES-AUDIO-SENTINEL-WEB	List \$899.00	\$854.05
------------------------	---------------	-----------------



Super Silence Monitors and More

Essential Workhorses from Broadcast Tools



Web-Enabled AES Switcher/Router

The AES Switcher Sentinel 4 XLR is a web-enabled, zero latency, transparent four input, one output switcher/router with mechanical latching relays designed to pass AES/EBU digital audio. It's perfect for passive AES signal switching via front panel controls, web browser controls, contact closures, TCP commands, and SNMP. When silence and/or out-of-phase audio is detected on the AES output it can automatically switch to a different AES input.

- Built-in web server for notification, monitoring, configuration and control
- Front panel, remote, and web-based switcher controls

AES-SWI-SENTINEL4-XLR List-\$829.00 **\$787.55**

Web-Enabled 2-Channel Silence and Phase Monitor

The Audio Sentinel 4 Web/RJ is Broadcast Tools' next-generation web-enabled two channel stereo silence and phase monitor with an integrated, transparent, 2x1 switcher. It is designed to monitor two analog audio sources, one primary, the other back-up. When silence is detected on the primary input it can automatically switch to the back-up input via mechanical latching relays.

- Built-in web server provides web-based (HTML5) notification, monitoring, configuration, and control
- Support for STARTTLS secure SMTP authentication (gmail, etc.)
- Front panel, remote, and web-based switcher controls

AUDIOSENTINEL-PLUS-WEB-RJ List-\$619.00 **\$588.05**



AES-AUDIO-SENTINEL4-WEB



AUDIOSENTINEL-4-WEB

Web-Enabled 4-Channel Silence Monitors

The Audio Sentinel 4 >> Web and AES Audio Sentinel 4 >> Web are web-enabled four channel stereo/eight mono channel silence monitors. The Audio Sentinel 4 >> Web features four balanced analog stereo inputs while the AES Audio Sentinel 4 >> Web features four AES/EBU inputs. You can also configure the inputs to act as two separate mono channels, letting you monitor up to a total of eight different mono audio sources. You can configure each channel for silence, stereo out of phase, and error monitoring as well as generate email/SNMP alarms.

AUDIOSENTINEL-4-WEB List-\$619.00 **\$588.05**
 AES-AUDIO-SENTINEL4-WEB List-\$1,639.00 **\$1,557.05**

6x1 BNC Switcher

The SS 6.1 MLR/BNC is a transparent 6x1 BNC switcher designed for N+1 installations and other applications where MPX baseband, AES-3id, or other unbalanced signal switching is necessary. Switching is accomplished using mechanical latching gold contact relays. Control via front panel controls and/or remotely with simple opto-isolated contact closure inputs and dry contact status relay outputs, as well with RS-232 serial commands, or TCP/UDP commands over Ethernet.

SS6.1MLR-BNC List-\$679.00 *

*Prices too low to advertise. Call BSW for the lowest price 1-800-426-8434.

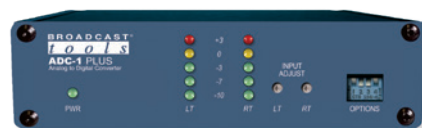

Reliable Analog to Digital Converter

Delivering high quality analog to 24-bit digital audio conversion, the ADC-1 Plus is ideal for converting the analog output of equipment to stereo AES. It offers balanced stereo analog inputs and AES output via XLR connectors.

ADC1-PLUS List-\$599.00 **\$569.05**



Essential GPI Interface

The Broadcast Tools GPI-16 Plus interfaces 16 general-purpose logic inputs to a PC COM or USB port.

- Four user-selectable unit IDs
- Four user-selectable baud rates
- USB and RS-232 interface for connection to PC

GPI-16-G2 List-\$319.00 **\$303.05**
 GPI-16-G2NET List-\$349.00 **\$331.55**



Transparent Silence Detector

- Transparent stereo/dual-mono silence monitor
- Front panel, remote control and relay monitoring
- Plug-in euroblock screw terminals

SILENCE-SENTINEL-BASICG2 List-\$259.00 **\$246.05**



1RU RJ45 to XLR Rack Panels

Converts XLR jacks to RJ45s using the standard Cat5 audio pinout. For each pair of XLRs there are three RJ45s allowing for stereo on one RJ45 or mono/AES on individual RJ45s.

RJ-XLR-16F R16 XLR-F jacks, for 8 stereo in or 16 mono/AES in List-\$319.00 **\$303.05**
 RJ-XLR-16M 16 XLR-M jacks, for 8 stereo out or 16 mono/AES out List-\$319.00 **\$303.05**

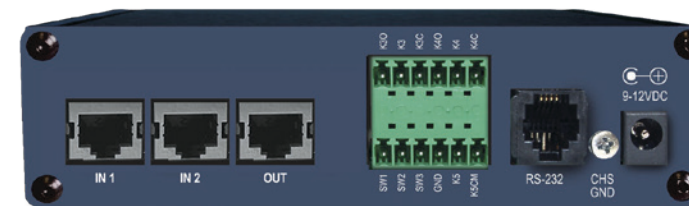

Back

SS2.1MLR-RJ



Front

SS2.1MLR-RJ

RJ45 Audio Switchers/Routers

The SS 2.1 MLR/RJ is an updated version the SS 2.1 MLR switcher/router that uses RJ45 jacks for audio I/O instead of removable screw terminal block connectors. SS 2.1 MLR/RJ is perfect for all types of passive signal switching via front panel switches, contact closures and/or serial RS-232.

SS2.1MLR-RJ 2x1 RJ Switcher/Router List-\$369.00 **\$350.55**

The SS 4.1 MLR/RJ is an updated version of the SS 4.1 MLR switcher/ router that uses RJ45 jacks for audio I/O instead of removable screw terminal block connectors. SS 4.1 MLR/RJ is perfect for all types of passive signal switching via front panel switches, contact closures and/or serial RS-232.

SS4.1MLR-RJ 4x1 RJ Switcher/Router List-\$489.00 **\$464.55**

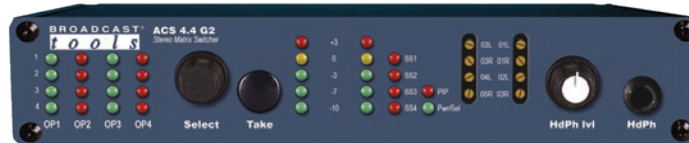

Powerful Matrix Audio Switcher

The ACS 4.4 G2 provides matrix audio switching of 4 stereo inputs to 4 stereo outputs, allowing any/or all inputs to be assigned to any/or all outputs. You can control it via its front panel rotary encoder control knob and TAKE switch, contact closures, open collectors, logic and/or the multi-drop RS-232 serial port. It offers easy installation with RJ45 audio jacks for input and output connections and plug-in euroblock screw terminal connectors for expansion and remote control.

- 4x4 balanced analog stereo matrix audio switcher
- Internal silence sensors monitor each output and provide front panel LED silence indicators and silence alarm open collector outputs
- 16 input GPI / Triggers port with front panel
- Electronically balanced stereo inputs and outputs

ACS4.4-G2 Matrix Audio Switcher List-\$979.00 **\$930.05**
 ACS8.4-G2 8x4 Matrix Audio Switcher List-\$1,849.00 **\$1,756.55**



Web-Enabled AES Switcher with Silence Sensor

The AES Switcher Sentinel 2+1 is a web-enabled three channel AES/EBU silence monitor combined with an integrated 3x1 AES switcher, designed to monitor two AES audio sources and one analog to digital (ADC) audio source. When it detects silence on the primary AES input, it can automatically switch to the back-up AES input or the backup ADC input via mechanical latching relays. You can configure and monitor it locally and/or remotely over any IP network, and can operate it using a desktop web browser or web-enabled mobile device.

- Front panel, remote, and web-based switcher controls
- Both AES inputs and analog input feature silence sensors/phase monitors with front panel activity and alarm LED indicators
- Can alert up to eight recipients when it detects alarms
- Stereo LED level display

AES-SWI-SENTINEL-2IN1 AES Switcher List-\$1,129.00 **\$1,072.55**





SS2.1MLR-TERM

Versatile Passive Audio Switchers

Broadcast Tools switchers offer local and remote control and status via contact closures and RS232 serial ports.

- SS2.1MLR/BNC: transparent, two input, dual output switcher/router with mechanical latching relays and BNC connectors
- SS2.1 MLR/Term: passive switching/routing with two inputs and two SPDT relay outputs; routes in either direction; mechanical latching relays, terminal connectors
- SS2.1 MLR/RJ: same as above but with RJ45 inputs and a single output

SS2.1MLRBNC	2x2 composite switcher	List \$369.00	\$350.55
SS2.1MLR-TERM	2x1 stereo switcher	List \$369.00	\$350.55
SS2.1MLR-RJ	2-input, 1-output (RJ45)	List \$369.00	\$350.55



8x4 AES/Analog Matrix Switcher

The ADMS 44.22 G2 provides matrix audio switching of 4 RJ45 analog inputs, 4 XLR AES inputs, 2 RJ45 analog outputs, 2 XLR AES outputs. Matrix switching allows any/all inputs to be assigned to any/all outputs. Control via its front panel push-button controls, contact closures, open collectors, logic, multi-drop RS-232 serial and/or TCP/UDP Ethernet commands. Installation is simplified with RJ45 audio jacks for analog input and output connections, XLR jacks for digital input and output connections, and plug-in euroblock screw terminal connectors for remote control.

ADMS44.22-G2	List \$2,369.00	\$2,250.00
--------------	-----------------	-------------------



Site Sentinel 16 G2

The Site Sentinel® 16 G2 is a robust, full-featured, web-enabled sixteen channel remote control featuring a desktop/mobile browser compatible web interface (HTML5.) The system is equipped with 16 metering inputs, four virtual metering channels, 16 opto-isolated status (logic) inputs, 33 programmable relays, four temperature probe inputs, one internal temperature sensor, stereo silence sensor, and power failure input. Includes a built-in scheduler, macros, and support for email alarms and SNMP.

SITESENTINEL16-G2	List \$1,719.00	\$1,633.00
-------------------	-----------------	-------------------

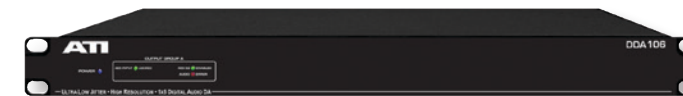

DDA106-XLR



DDA212-XLR

Dynamite Digital Distribution Amplifiers

ATI's Series 2 Digital Audio Distribution Amplifiers can distribute digital audio at up to 192 kHz sample rates with ultra-low jitter and ultra-short propagation delay. Switchable inputs let you choose from multiple input streams. Selectable re-clocking lets you precisely regenerate a pristine input signal or handle Surround-encoded audio. Sample Rate, Word Length, Fault Diagnostic and Pro/Consumer displays tell you your audio is clean or let you know why it's not.

ADA206-XLR	2x6 XLR digital DA	List \$1,625.00 *
ADA-208-XLR	2x8 XLR digital DA	List \$1,865.00
ADA412-XLR	4x12 XLR digital DA	List \$2,185.00
ADA416-PHX	4x16 XLR digital DA	List \$2,185.00
DDA106XLR	1x6 XLR digital DA	List \$2,055.00
DDA106-WC106-XLR	1x6 digital DA w/ 1x6 word clock	List \$2,285.00
DDA208-XLR	Dual 1x4 (2x8) digital DA	List \$2,285.00
DDA212-XLR	Dual 1x6 (2x12) digital DA	List \$2,495.00

*Prices too low to advertise. Call BSW for the lowest price 1-800-426-8434.

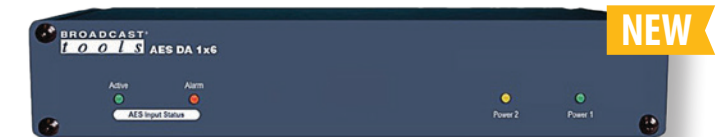

NEW

Loaded AES/EBU Distribution Amplifier

Broadcast Tools' AES DA 1x6, six XLR output, one-input AES/EBU distribution amplifier is ideal for distributing balanced AES/EBU signals or wordclock.

AESDA1X6	List \$489.00 *
----------	-----------------

*Prices too low to advertise. Call BSW for the lowest price 1-800-426-8434.



Clean, Ultra-Quiet Analog Audio Distribution

The ADA208 gives you clean, quiet > 90dB EIN audio performance. Each of its two Phoenix inputs can drive its four individually adjustable, active balanced Phoenix outputs (each with individual level control). The ADA208 is RF protected and eliminates noise from lossy splitters while driving long lines.

ADA-208-XLR	Dual 1x4 Low Noise Analog Distribution Amplifier, Phoenix I/O	List \$1,865.00 *
-------------	---------------------------------------------------------------	-------------------

*Prices too low to advertise. Call BSW for the lowest price 1-800-426-8434.



NEW

Feature-Rich Analog Silence Detector/Switcher

The Broadcast Tools Silence Sentinel RJ monitors any two stereo analog audio sources for silence or an out of phase condition (polarity), generate alarms, and transparently switch to a back-up source using mechanically latching relays.

It features front panel controls, remote control inputs and status relay outputs, RJ45 audio connectors, plug-in euroblock screw terminals for remote control, dip switch configuration of silence detection from -20, -25, -30 and -35db below zero reference, precise alarm timing delay from off to 85 minutes, and precise restore timing delay from off to 21 minutes.

SILENCE-SENTINEL-RJ	List \$439.00	\$417.05
---------------------	---------------	-----------------



NEW

Hard-Working 6-Channel Relay Module

The Broadcast Tools Box O' Relays 6 is a six-channel optically isolated relay module that's ideal for converting GPO outputs from AoIP systems and other devices to dry contact closures. It features six SPDT relay outputs pluggable screw terminal block connectors for ease of installation.

BOXORELAY-6	List \$189.00	\$179.55
-------------	---------------	-----------------



Loaded D/A Audio Converter

The Broadcast Tools DAC-1 is a 24-bit stereo digital-to-analog audio converter boasting an SPDT alarm relay that's configured to close when an analog silence and/or an AES error is detected.

- Front panel silence sensor
- AES error status and sample rate LED indicators
- AES input and balanced stereo output

DAC-1	List \$629.00	\$597.55
-------	---------------	-----------------



2X6DA-PLUS-RJ

High Performance Distribution Amps

- Active balanced low Z output amplifiers and a stereo line level high Z input that accepts a balanced or unbalanced source
- Each output amp can be paired for stereo or each output pair can be summed for mono operation without degrading the integrity of the other outputs
- 2x6 and 2x10 available with terminal block connectors. 2x16 with RJ45 jacks

2x16DA-RJ	16 outputs	List \$439.00	\$417.05
2X10-DA	10 outputs	List \$369.00	\$350.55
2X6DA-PLUS	6 outputs	List \$319.00	\$303.05
2X6DA-PLUS-RJ	6 outputs with RJ45 jacks	List \$319.00	\$303.05



8-Channel Distribution Amp with Balanced I/O

The Rolls RA163 eight-channel mono, or four-channel stereo distribution amplifier designed for the contractor/install market. The outputs are designed to drive high-level balanced lines in a sound distribution system. The XLR jacks on the rear panel are for input and output, and each output may power more than one line.

RA163	List \$229.00	\$229.00
-------	---------------	-----------------



BSW CUSTOMER FAVORITE

Flexible Distribution Amps

Accepts balanced and unbalanced sources!

Henry Engineering's U.S.D.A. can work as a 1x4 or 2x4 DA. Its two inputs (one stereo pair) accept balanced/unbalanced sources and offers four balanced outs (two stereo pairs). The AES Digital DA 2X4 can accept either an AES or S/PDIF digital audio stream and create four identical AES outputs.

USDA	\$325.00
AES-DA2X4	\$350.00



BSW CUSTOMER FAVORITE

1x3 AES Distribution Amplifier

The Inovonics INOmini 300 is a compact, DSP-based 1x3 distribution amp specifically for AES digital audio. INOmini 514 decodes FM-stereo multiplex signals.

300-00	List \$790.00	\$711.00
--------	---------------	-----------------



Scan for more information.

BRING DEAD AIR BACK TO LIFE WITH BROADCAST TOOLS SILENCE SENSORS! 800.426.8434

DIGITAL AUDIO SOLUTIONS!

The AES Digital D.A. routes digital audio to four destinations.



- Four outputs with individual transformer isolation
- Zero Delay means no latency or timing issues
- Bit-accurate outputs are exact copies of source
- Use either AES or S/PDIF input source

The AES DigiSwitch 3X1 switches between 3 digital sources.

- Zero latency, bit-accurate throughput
- Illuminated pushbutton input selection
- Remote control via easy GPI interface
- Auto-Return to #1 is user-programmable

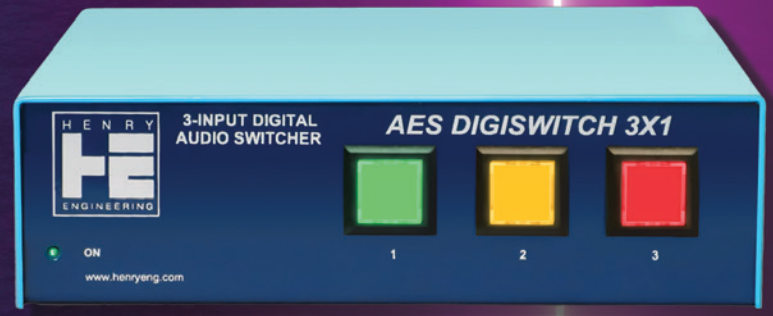

USB Matchbox II is the industry standard for PC/Mac audio interface!



- Burr-Brown DAC/ADC for audiophile performance
- Balanced analog I/O, plus AES digital output
- True pro studio levels with generous headroom
- Headphone monitor of Playback audio
- Plug-And-Play with Windows, Mac I/O, Linux



We Build Solutions



Call BSW for your best price on
Henry Engineering 1-800-426-8434

INTERFACE EQUIPMENT

Henry Engineering Makes Audio Interfacing Simple

Brilliant LED Tally Light Controller

SUPERLIGHT is a handy logic/control interface controls low voltage studio tally lights. It can directly power 12 volt DC LED tally lights that draw up to 500 mA. It includes a flasher circuit, as well as a DPDT relay output that can be used for any low voltage switching, speaker muting or other utility use.

SUPERLIGHT \$195.00



Smooth, Transparent Balanced/Unbalanced Interfacing

The Henry Engineering Matchbox HD provides bidirectional stereo interfacing between unbalanced and balanced audio. The TwinMatch interfaces two unbalanced consumer stereo outputs with professional balanced equipment. The USB Matchbox II USB-to-XLR multi-mode stereo audio codec offers superb audio performance with the ease of USB connectivity.

USBMATCHBOXII USB to XLR Interface **\$575.00**
MATCHBOXHD Bi-directional interface amplifier **\$250.00**
TWINMATCH Unbalanced-to-balanced amplifier **\$295.00**

USBMATCHBOXII:
 • 2 balanced analog inputs; 2 balanced analog outputs
 • AES/EBU digital output; headphone output
 • Sample rates up to 48 kHz and 16 bit resolution
 • Steel chassis for effective RF shielding

MATCHBOX HD:
 • True SNR of 100 dB, with 22 dB of headroom
 • Total dynamic range of 122 dB
 • 4 independent amplifiers; built-in AC power supply
 • Balanced XLR and unbalanced RCA I/O

TWINMATCH:
 • Converts to professional 600 ohm balanced lines
 • Adjustable gain to accommodate either +4 or +8 dBm systems
 • Circuitry is direct-coupled and transformerless for sonic transparency
 • Unbalanced RCA inputs, balanced XLR outputs



Ideal Utility Control Interface

Henry Engineering's Superelay II is a multi-circuit controller for any application where numerous circuits need to be switched simultaneously. It's ideal for controlling On Air tally lights and switching a variety of equipment functions.

SUPERELAYII \$395.00



Loaded UPS Power Controller

BackUPS is a power controller for ensuring reliable AC power to critical equipment that is powered with an Uninterruptible Power Supply (UPS). It constantly monitors the output of the UPS and automatically bypasses the UPS if its output fails or becomes unstable.

BACKUPS \$325.00



AES Digital Audio Switcher

AES DigiSwitch 3X1 is a three-input switcher for AES digital audio signals. It accepts up to three AES audio sources, selecting one that is sent to the AES output.

DIGISWITCH-3X1 \$395.00

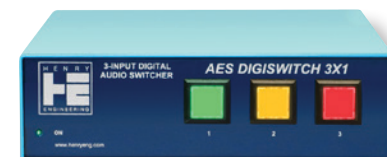

Effective Tally Light Control

Mike-Alert is an interface device for controlling the dual-color tally indicators on popular mic arms. It can independently control two mic arms' tally lights, providing power and control circuitry to operate the white and red tally indicators in each arm.

- 3 pins are used for mic audio
- 2 pins are used for the tally LED lighting
- Mic audio is passed-through to a standard 3-pin male XLR for connection to an audio consoles

MIKE-ALERT \$325.00



Multi-Format Audio Interface Panel

The Henry Engineering MultiPort offers convenient access to a studio's analog and digital audio inputs and outputs, and allows connection to both professional and consumer gear. It accepts balanced or unbalanced analog stereo Line inputs, and digital I/O can be via either the AES/EBU or S/PDIF standard. The digital I/O is transformer isolated. XLR, TRS, 3.5mm TRS, and phono jacks are provided for interface. It also provides both balanced and unbalanced analog stereo Line outputs, plus two monaural balanced Mic outputs.

HENRY-MULTIPORT \$575.00

Easily Connect with Your Guests & Audience



More online!
Scan for full specs.



See the video at <https://youtu.be/OS9AfORo1YA>

Easy IP Audio for Guest Interviews

The Comrex Opal IP audio gateway enables guests to connect to the studio by simply clicking a link. It provides HD quality audio from consumer-grade equipment, such as a cellphone or a computer with a microphone.

- Supports two discrete connections at once
- Guests just click a button and go live
- No technical background needed to connect and transmit HD audio
- Works with commonly used browsers like Chrome, Firefox and Opera
- Audio encoded using Opus
- Left and Right tri-color LEDs display channel status/audio level
- Balanced XLR analog and AES3 XLR digital I/O
- Ethernet port, contact closures and serial port
- Compact 1/2 U rack size
- Works with Apple Safari browser

OPAL List \$1,700.00*

*Prices too low to advertise. Call BSW for the lowest price 1-800-426-8434.



Two Line VoIP Hybrid

A dual-line hybrid, VH2 connects two VoIP lines for individual broadcast or flawless conferencing. VH2 prevents echo and distortion, and automatically adjusts caller audio to a uniform level, leaving you with a result that's clean and clear. Plus, VH2 uses VoIP phone lines, saving you money and increasing functionality. VH2 can even connect to many VoIP PBX systems.

- Prevents echo and other artifacts
- G.722 codec support for wideband calls. Also supports G.711
- Receive filter reduces telephone line noise

VH2 VoIP Hybrid List \$1,500.00*

*Prices too low to advertise. Call BSW for the lowest price 1-800-426-8434.



BSW Thanks You

Sometimes it's hard to believe we've been doing this for over 50 years. But what's easy to believe is we couldn't have done it without loyal customers like you. Thank you for your trust in us. Thank you for giving us the opportunity serve you.

800.426.8434

Comrex gear is so impressive, it basically sells itself. Wait, don't tell the boss I said that!

800.426.8434

Jamie Singer, GearHead,
JamieS@bswusa.com



Big or small, hardware or software, there's a Telos® VX phone system for you.

When it comes broadcast phone systems, no one delivers like Telos. In fact, we invented VoIP for broadcast! Flawless call quality, unparalleled flexibility and ease of operation, and system configurations to fit any scenario are just a few of the reasons that broadcasters worldwide choose Telos VX systems. Hardware-based Telos VX Enterprise is purpose-built for medium to large facilities, expandable up to 120 channels. Compact Telos VX Duo hardware is right-sized for smaller facilities, starting with 2 channels and expandable to 4, 6, or 8 channels. Software-based Telos VXs delivers all of the power and quality VX hardware systems are known for, with the advantage of flexible local or cloud-based virtual deployment options. No matter your size or budget, you'll find a Telos VX system that's the perfect fit.

Need help figuring out which VX is right for you?

Contact us - we're here to help.

Telos VX® Enterprise



The first (and finest) broadcast VoIP phone system. for medium to large facilities.

Telos VX® Duo



Small but mighty! Big Telos VX features in a package that fits anywhere.

Telos VXs



Everything you love about the Telos VX broadcast phone system, delivered virtually.

Flexible Phone Systems for Clear Caller Audio

See the video at bswusa.com/VX



More online! Scan for full specs.



BSW CUSTOMER FAVORITE

Directs up to 80 lines of phone traffic!

Multi-Studio VoIP Phone System

The first and finest VoIP broadcast phone system, VX Enterprise is ideal for medium- to large-scale radio and television facilities. The VX Enterprise hardware appliance sits at the core of this expandable platform, capable of providing up to 120 channels/hybrids in a slim 1RU package. Clean, clear caller audio is the hallmark of VX Enterprise, featuring a smart AGC, a 3-band adaptive dynamic EQ, and a 3-band spectral processor, noise gating, and Acoustic Echo Cancellation. Build a complete system around VX Enterprise with Telos Alliance xNode AoIP interfaces and VSet call controllers. Supports Livewire and AES67 for SMPTE ST 2110-30 networks Standards-based SIP interface integrates with hosted VoIP or VoIP-based PBX services Connects to any console or broadcast equipment via Telos Alliance xNode AoIP interfaces Native integration with Telos VSet phones HTML-5 control via Pathfinder Core PRO.

VX-ENTERPRISE	VoIP Phone System (24 hybrids)	List \$10,995.00	\$9,896.00
VX-ENTERPRISE-ADD-PACK	VX Enterprise Additional 8 Hybrid License Pack	List \$3,995.00	\$3,596.00
VSET-DESKTOP-CONTROLLER	VX Controller	List \$1,695.00	\$1,526.00
VSET12	12 phone lines	List \$1,255.00	\$1,130.00
VSET6	6 phone lines	List \$995.00	\$896.00

Telos



VSET12

New VX Duo Broadcast Phone System

Telos VX broadcast phone systems are the industry standard for bringing phone calls into any broadcast facility. VX Duo brings the same audio performance and user experience you'll find in the flagship VX Enterprise system to a compact, completely silent platform. It is an ideal choice for home and project studios and broadcast facilities where all equipment is located inside a control room or studio, and the price puts VX Duo within reach of any budget.

- Delivers the same call quality and user experience as the flagship VX Enterprise system, including the same audio processing, noise gating, and acoustic echo cancellation features
- Includes 2 channels/hybrids, expandable to 8 channels/hybrids via additional 2 channel expansion licenses
- Compact, fanless, and silent
- Ideal for in-studio use
- Works with all Telos VSet call controllers and VX-compatible call screening software

VX-DUO VoIP Talkshow System (includes 2-channel/hybrid base license) List \$1,995.00 **\$1,796.00**

VX-DUO-SYS-1 Talk show system – 2 hybrids w/VSET6, xNode, and PoE Switch *

VX-DUO-SYS-2 Talk show system – 2 hybrids w/VSET12, xNode, and PoE Switch *

*Prices too low to advertise. Call BSW for the lowest price 1-800-426-8434.

Easy to understand set controls Intuitive IP-Based Call Controllers

VSet IP-based telephone controllers for the Telos VX VoIP phone system connect via Ethernet to provide comprehensive system control. Their large, colorful VGA LCD displays provide intuitive operation and setup, while exclusive animated Status Symbol icons give producers and talent line/caller status at a glance. The info-rich display shows caller ID for each line, along with time ringing-in or on-hold, and even screener comments from the VX Producer software application.

Easy-to-understand VSet controls, with a friendly visual interface, let talent manage incoming lines, lock calls on-air, start an external recording device, and take a queue of calls to air sequentially, for precise management of multi-call interviews or conferences.

The VSet6 can control up to six phone lines, while its big brother VSet12 can handle up to 12.

VSET6	6-line phone controller	List \$995.00	\$896.00
VSET12	12-line phone controller	List \$1,255.00	\$1,130.00

Tuners



Triple Tuner/EAS Monitor Receiver

The 677 Triple Tuner is an EAS Monitor Receiver in a compact half-rack package. It has three built-in unique receivers, each capable of AM, FM or NOAA reception. Each receiver has a balanced monoaural XLR audio output to serve as EAS monitor or on-air monitor throughout the broadcast facility. The 677 has an easy front panel set-up with

jog-wheel menu navigation and front panel readout. On the back panel, six rear-panel GPOs may be user-assigned to alarm functions. The dynamic Web interface provides control & monitoring remotely via any Web enabled device. In addition, remote listening by Web stream along with alarms/notification via email and SMS messages. SNMP is fully supported.

677 With LED meters and touch LCD List \$2,300.00 **\$2,070.00**



Rack Mount RDS Tuner with XLR Outputs

The Rolls RS81B is a single rack space Phase Lock Loop digital AM/FM Tuner designed for a wide range of professional applications. It offers storage of up to 30 FM and AM stations, RDS display, an auto search function, a headphone output and balanced XLR outputs.

- Large LCD digital display
- Retains presets when power is off
- Remote included

RS81-B Rack mount RDS tuner w/XLR List \$379.00 **\$319.00**

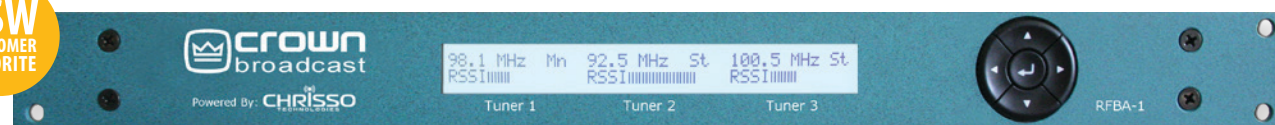

Loaded AM/FM/Weather Radio Tuner

The Crown Broadcast RFBA-1 AM/FM/WR broadcast receiver comes standard with three receivers built into a 1-RU chassis, and is configurable to accommodate any mix of FM and AM stations plus WR. This simple-to-deploy, highly sensitive, fully DSP-based monitor system is fully frequency agile in all receivers via display and excels as a translator receiver, EAS monitor or on-air monitor.

It also offers a PC based user interface, programmable output relay, firmware updates via USB port and an RDS encoder and decoder.

- FM Tuning Range: 76 to 108 MHz (50 kHz steps)
- AM Tuning Range: 520 to 1710 kHz (10 or 9 kHz steps)
- Weather Radio Tuning Range: 162.4 to 162.55
- Antenna Input: BNC 50 Ohm
- RDS: Encoder/Decoder
- Carrier: Display indicated
- Modulation: Display indicated

RFBA-1 List \$1,945.00*

*Prices too low to advertise. Call BSW for the lowest price 1-800-426-8434.

Let BSW Help You Find The Right Phone Gear



Dual Digital Hybrid

State-of-the-art in hybrid performance, with Telos processing technologies that take the POTS hybrid to a new level of consistently superior performance, regardless of telephone line characteristics.

HX1	Analog In/Out	List \$1,095.00	\$986.00
HX1-AES	Analog/AES In/Out	List \$1,345.00	\$1,211.00
HX2	Analog In/Out	List \$1,895.00	\$1,706.00
HX2-AES	Analog/AES In/Out	List \$2,095.00	\$1,886.00

Intuitive Digital Hybrids

JK Audio's AutoHybrid gives you simultaneous send and receive audio through analog telephone lines. This desktop unit features a passive auto-answer/disconnect interface and is rackable (4-across) with the optional RA4 shelf. The InnKeeper LTD digital hybrid connects audio signals to a standard analog telephone line without the transmit/receive crosstalk common to analog hybrids. Its DSP continuously monitors both the phone line and audio signals to deliver excellent separation. The Innkeeper PBX connects audio signals to your PBX type telephone system through the telephone handset cord.

AUTOHYBRID List \$255.00

Accessories:

RA4 Rack shelf List \$70.00

INNKEEPERLTD List \$640.00

INNKEEPERPBX List \$575.00

Accessories:

GUESTMODULE1 Remote control interface List \$230.00*

RA2 Rackmount kit List \$70.00

"Provides sound just like any thousand dollar model."



*Prices too low to advertise. Call BSW for the lowest price 1-800-426-8434.



Host with the Most

JK Audio's Broadcast Host digital hybrid turns your desktop into a professional broadcast center. It contains everything you need to get talk show-quality phone audio into your mixer or sound card for recording or broadcast. Broadcast Host lets you send mic and line level signals into the phone line while maintaining excellent separation between your voice and the caller's. A proprietary dual-convergence echo canceller algorithm can achieve superb separation, typically exceeding 50 dB, without any setup and without sending a noise burst down the line.

HOST List \$575.00

*Prices too low to advertise. Call BSW for the lowest price 1-800-426-8434.

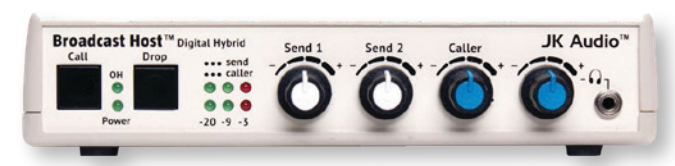

Desktop Digital Hybrid

The JK Audio Universal Host easily converts your IP or PBX telephone into a professional, affordable interview station. This desktop digital hybrid provides talk show quality caller audio from most telephone systems. Simply connect between your telephone handset and the base of your telephone. The 16-bit USB audio CODEC allows stereo recording at up to 48 kHz sampling rate, with the talent voice on the left channel in full bandwidth, and the caller on the right. Play recordings from your computer directly into the phone system. The digital hybrid connects audio signals to your IP or PBX type telephone system through the telephone handset cord.

UNIVERSALHOST List \$695.00*

*Prices too low to advertise. Call BSW for the lowest price 1-800-426-8434.



Telos Z/IPStream: Online Audio Done Right



Compact, Powerful Streaming Audio Encoders

The Telos Z/IPStream R/1 combines audio processing with MP3 and AAC encoding in one convenient, single-rack unit. The Z/IPStream R/20 offers multiple channels of processing and encoding, as well as a 3-band audio processing.

- Z/IPStream R/1:**
- Audio pre-processing, stream coding and delivery to remote replication server
 - Pro-grade 24-bit A/D converter for studio-reference quality audio
 - Wideband AGC, 3-band compressor/limiter, EQ, low-pass filter and precision look-ahead final limiter
- Z/IPStream R/20:**
- Up to 8 channels of processing and stream encoding
 - 3-band or full Omnia.9 processing 3-band, Omnia Forza, or Omnia.9 processing
 - AES/EBU and Livewire+/AES67 audio I/O
 - AC-LC, HE-AAC, HE-AAC v2, xHE-AAC, and MP3 stream encoding

ZIPSTREAM-R1	3-Band Processing (Two Streams)	List \$2,645.00 *	
ZIPSTREAM-R20	R/20 Option for Additional Program Input	List—\$8,495.00	\$7,646.00
ZIPSTREAM-R20-ADDP	R/20 Forza Processing	List—\$695.00	\$626.00
ZIPSTREAM-R20-FORZA	R/20 Omnia.9 Processing	List—\$995.00	\$896.00
ZIPSTREAM-R20-OMNIA9	R/20 déjà vu 5.1 Upmixing	List—\$1,895.00	\$1,706.00
ZIPSTREAM-R20-DEJAVU	R/20 Kantar Watermarking License Option	List—\$1,895.00	\$1,706.00
ZIPSTREAM-R20-KANTAR	R/20 Nielsen Watermarking License Option	List—\$295.00	\$266.00
ZIPSTREAM-R20-NIELSEN	R/20 Nielsen Watermarking License Option	List—\$995.00	\$896.00

*Prices too low to advertise. Call BSW for the lowest price 1-800-426-8434.

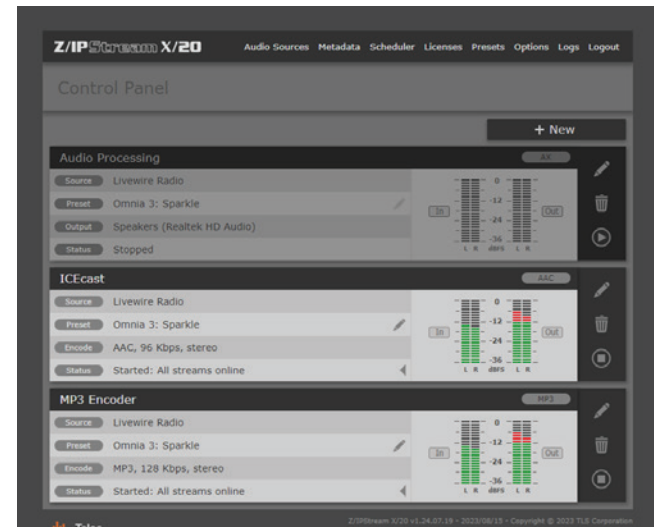

ZIPSTREAM-X20

Processes, Encodes and Streams Audio for Multiple Platforms and Bit-Rates Simultaneously

Z/IPStream X/20 is an all-in-one streaming audio software encoder and processing platform for Windows PCs and servers. Featuring Adaptive Streaming capability, X/20 supports Apple HLS and Microsoft Smooth Streaming formats, allowing media players to automatically adapt to changing network conditions by encoding at multiple bitrates. Sample-aligned output streams enable listeners' media players to seamlessly switch between bitrates in response to Internet conditions. A number of popular encoding formats including MP3, AAC-LC, HE-AAC, HE-AAC v2, and xHE-AAC are supported. Simultaneous MP3/AAC/aacPlus encoding is compatible with Shoutcast, Icecast, Wowza, and RTMP servers.

X/20 is licensed on a per-program input basis. A base license includes effective and proven Omnia 3-band processing. More advanced processing options include Omnia Forza and Omnia.9 algorithms. License support options for Kantar and Nielsen allow each input stream to be separately watermarked. The Déjà Vu option provides stereo up mixing to 5.1-channel surround using the MPEG-Surround codec, supported by most player apps, with full stereo compatibility.

ZIPSTREAM-X20	Streaming Software Encoder and Processor for Windows	List—\$695.00	\$626.00	ZIPSTREAM-X20-DEJAVU	X/20 add Déjà Vu 5.1 upmixing, buyout	List—\$1,895.00	\$1,706.00
ZIPSTREAM-X20-FORZA	X/20 Omnia Forza Processing, buyout	List—\$995.00	\$896.00	ZIPSTREAM-X20-NIELSEN	X/20 Nielsen watermarking license option, buyout	List—\$995.00	\$896.00
ZIPSTREAM-X20-OMNIA9	X/20 Omnia.9 Processing, buyout	List—\$1,895.00	\$1,706.00	ZIPSTREAM-X20-KANTAR	X/20 Kantar watermarking license option, buyout	List—\$295.00	\$266.00



Powerful Call Handling System

AEQ's SYSTEM IP is a powerful multi-line call handling system that enables stations to handle multiple calls across one or more studios.

The SYSTEMSET+ is a VoIP handset that seamlessly works with the SYSTEM 16.



It combines the functions of a standard VoIP handset with a dedicated touch screen running the built in Systal Control software.

The 1U rackmount SYSTEM 16 is ideal for a multi-studio environment where you need a high number of lines in each studio. It offers up to 16 SIP phone lines that can be used in a single studio or shared between multiple studios. It also features built-in Dante AoIP so all 16 lines can be accessed as individual audio channels by any Dante enabled device. It's compatible with IP PBX, SIP Trunking and virtual PBX.

SYSTEM-SET-PLUS	Handset with touchscreen	List—\$1,130.00 *
SYSTEM-IP16	Multi-Line telephone system	List—\$7,200.00

*Prices too low to advertise. Call BSW for the lowest price 1-800-426-8434.



VoIP Solution For TV IFB

Comrex EarShot IFB is designed to provide telephone-based live studio program and IFB audio to field-based remote broadcasts, such as TV ENG reports. Up to 30 callers can dial in and listen to the audio feeds. This allows you to replace up to 30 POTS lines with one simple box and considerably lessen your expenses. Its selectable feeds feature lets you configure some feeds with full program audio and use mix-minus on other feeds to prevent echo and other audio flaws.

- Cost-saving VoIP technology
- Can handle up to 30 callers and replace up to 30 POTS lines
- Four audio inputs (or two IFB inputs)
- Selectable audio lines
- Uses G.711 (can be configured for higher quality audio)

EARSHOT-IFB	VoIP auto-coupler	List—\$3,500.00 *
--------------------	-------------------	-------------------

*Prices too low to advertise. Call BSW for the lowest price 1-800-426-8434.

JK Audio Telephone Taps

JK Audio has a wide range of phone taps for every need. The Daptor Three audio interface offers Bluetooth wireless as well as balanced XLR and unbalanced 3.5 mm connections to let you send and receive audio through your cell phone. The Daptor Two plugs into the headset jack of any wireless phone or notebook computer that accepts a third party headset or earpiece. Send and receive voice band audio during regular calls, or full bandwidth audio using third party codec applications.

Connect the THAT1 or THAT2 between your telephone and handset for quick access to audio. CellTap easily records audio from your cell phone. Use QuickTap between your standard telephone and handset for access to audio out of any telephone. VoicePath routes audio in and out of any telephone using your PC sound card. The Pureformer provides hum and noise reduction for sound cards and audio equipment.

- Top-shelf components
- Durable, high quality construction
- Made in USA

PUREFORMER	Isolation transformer	List—\$79.00 *
DAPTORTHREE	Bluetooth w/ XLR & 3.5mm	List—\$435.00
DAPTORTWO	3.5 mm TRRS w/ XLR & 1/4"	List—\$190.00
THAT1	Telephone audio tap w/RCA	List—\$150.00
THAT2	Telephone audio tap w/XLR	List—\$245.00
CELLTAP-4C	Wireless audio tap	List—\$105.00
QUICKTAP	Telephone audio tap	List—\$69.00
VOICEPATH	Phone tap	List—\$110.00

*Prices too low to advertise. Call BSW for the lowest price 1-800-426-8434.





NEW

Audio Recording Interface Works With Every Microphone type

AudioSigma's ultra-portable MikeHero works seamlessly with ALL microphones on the market. It features an exclusive dynamic/condenser microphone selector that fully adjusts the preamp circuit for each microphone type. From the quietest dynamic to the loudest condenser, MikeHero works perfectly with no need for additional hardware. MikeHero lets you record and broadcast using just your smartphone. Simply plug it to your iOS or android device, and get online instantly. Its powerful DSP takes the quality of your work to a whole new level - without post editing.

MIKEHERODSP Ultra-portable audio interface **\$289.00**



NEW

Ultra-Portable Audio Recording Interface

The Audiosigma PodMobile dual-channel portable USB-powered audio interface is ideal for podcasters, voice actors and remote broadcasters. It features two XLR mic channels with two phantom powered preamps that work seamlessly with a wide variety of microphones, incredibly intuitive Bass and Treble controls that let you quickly dial in your optimum sound, the ability to record using only your smartphone, and much more.

- Two XLR mic inputs; two headphone outputs
- Phantom powered preamps
- Works with a wide range of mics with no boosters or activators needed
- Records a podcast or interview using only your smartphone
- Handy USB connectivity
- Compatible with iOS, Android, Windows, Linux, and MacOS

PODMOBILEDSP Ultra-portable audio interface **\$359.00**

Focusrite



More online!
Scan for full specs.



SCARLETT-4I4-4G



SCARLETT-SOLO-4G

State-of-the-Art Audio Interfaces

Focusrite's new Scarlett 4th Gen USB audio interfaces offer premium mic preamps, refined monitoring features and enhanced performance for truly professional results. Available in a wide range of configurations, they boast plenty of I/O flexibility along with transparent high-gain, low noise preamps that deliver a brighter, more spacious sound. Call, email, or visit our website for full details.

SCARLETT-4I4-4G	4 in, 4 out, 2 preamps	List \$349.99	\$279.99
SCARLETT-8I6-3G	3rd Gen 8-in, 6-out USB audio interface	List \$359.99	\$281.24

SCARLETT-2I2-4G	2 in, 2 out, 2 preamps	List \$249.99	\$199.99
SCARLETT-2I2-STU-4G	2 preamps, mic, headphones	List \$379.99	\$299.99
SCARLETT-SOLO-4G	2 in, 2 out, 1 preamp	List \$179.99	\$139.99
SCARLETT-SOLO-STU-4G	1 preamp, mic, headphones	List \$319.99	\$249.99
SCARLETT-18I20-3G	3rd Gen 18-in, 20-out USB audio interface	List \$749.99	\$562.49
SCARLETT-18I8-3G	3rd Gen 18-in, 8-out USB audio interface	List \$569.99	\$421.86

Helpful Angry Audio Interface Equipment



USB-DIGITAL-AUD-GIZMO

USB Analog Audio Gizmo

The USB Analog Audio Gizmo isolates power, ground, and data lines between a computer and audio circuitry, making annoying ground loop noise a thing of the past. Powered by your computer's USB, it features fully balanced I/O, RJ45 audio ports (XLR adapters included) and much more.

AUDIO-GIZMO-ANALOG	List \$299.00	\$284.00
USB-DIGITAL-AUD-GIZMO	List \$499.00	\$474.00



Bidirectional Balancing Gadget

The Bidirectional Balancing Gadget converts one stereo pair from unbalanced to balanced and another stereo pair from balanced to unbalanced. It's perfect for a recording device or a computer soundcard. Unbalanced and balanced signals are on RCA/Phono jacks and XLR connectors, respectively.

BIDIRECTIONAL-BAL-GADGET List \$299.00 **\$284.00**



Controls Up to Five Studio Signal Lights

The Studio Signal Light Gadget boasts five LED drivers to light up to five different light segments. The front panel has LEDs that correspond to the segment colors; the adjacent switch lets you automatically trigger the lights via rear-panel GPI connections, or trigger each one manually.

STUDIO-SIGNAL-GADGET List \$349.00 **\$331.00**

Headphone Gizmo

The Headphone Gizmo gives headphones plenty of gain. Its precision analog circuitry delivers nuanced, transparent sound even at loud volumes, and it sports both 1/4 inch and 1/8 inch jacks for ultra-flexibility. Whether your talent uses full coverage phones or modern IEMs, the Headphone Gizmo will drive them perfectly.



HEADPHONE-GIZMO List \$229.00 **\$217.00**



Easily Put Your Smartphone On the Air

The Bluetooth Audio Gadget makes it easy to put a smartphone on the air. Just pair your phone, and the Bluetooth Audio Gadget automatically negotiates the optimal codec algorithm. Balanced audio I/O connects the Gadget to your console.

BLUETOOTH-GADGET List \$469.00 **\$445.00**

Silence Sensor and Backup Audio switcher

The Failsafe Gadget is a simple stereo A/B switch. When the Main (A) source is fed to the output, a sophisticated sensor monitors it constantly. If silence is detected, the Backup (B) source is switched to the output.



FAILSAFE-GADGET List \$399.00 **\$379.00**



Button Interface for Consoles

The Button Gizmo features four avionics-grade, LED illuminated pushbuttons in a powder-coated steel panel. It mounts easily in your countertop for an elegant, finished look. Any console with GPIO logic will easily interface with it.

BUTTON-GIZMO List \$129.00 **\$122.00**



Handy Headphone Disconnecter

The Headphone Disconnecter Gizmo mounts into your studio furniture for an elegant streamlined appearance. It's easy to install using a hole-saw and a screwdriver. The Disconnecter Gizmo includes the mating connector for your headphones (3.5mm jack).

DISCONNECT-GIZMO List \$89.00 **\$84.00**



Compact Cough Muter and More

The Guest Gizmo is a Cough button, headphone amplifier (with level control) and mic tally driver in one compact package. It uses your mixer's microphone insert jack to provide the muting function.

GUEST-GIZMO List \$239.00 **\$227.00**

Great Audio Requires Great Converters

State-of-the-Art PCI Express Sound Cards

Digigram ALP-X stereo sound cards for Windows and Linux operating systems are designed for the most demanding professional audio applications. Providing simultaneous use of analog and digital inputs/outputs, embedded mixers with full capacity, and a new, state-of-the-art technology core, they offer pristine sound quality, ultra-low latency, and rock-solid, life-long, hiccup-free reliability. The "MIC" models also boast an integrated mic preamp, making them a perfect match for slim form factor integrated systems.

ALP222E	PCIe stereo sound card	List \$662.00*
ALP222E-MIC	PCIe card with mic/line inputs	List \$899.00
ALP442E	Multi-channel PCIe sound card	List \$1,490.00
ALP442E-MIC	Multi-channel PCIe card w/ mic/line inputs	List \$1,890.00
ALP882E	Multi-channel low-profile PCIe sound card	List \$2,590.00
ALP882E-MIC	ALP882E with mic/line inputs	List \$2,990.00

*Prices too low to advertise. Call BSW for the lowest price 1-800-426-8434.

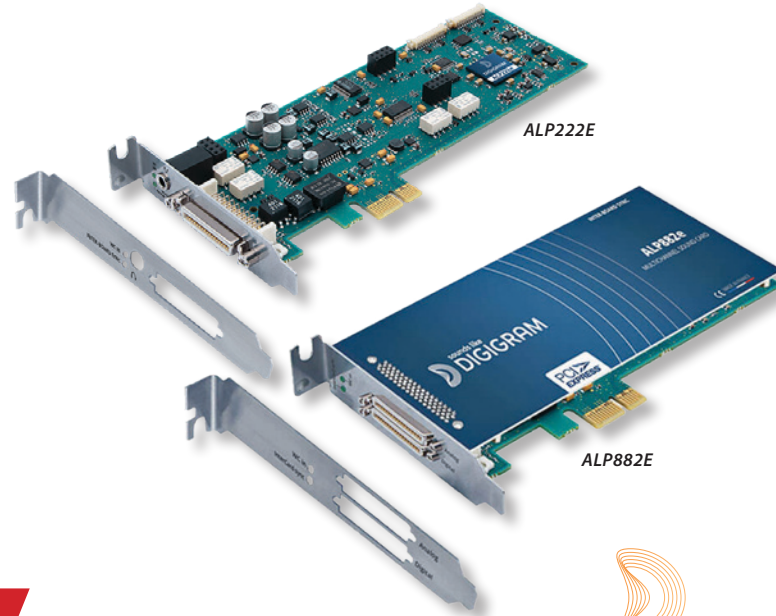

15-ISH SECONDS CAN SAVE YOU HUNDREDS –
CALL BSW FOR BEST PRICE! 800.426.8434

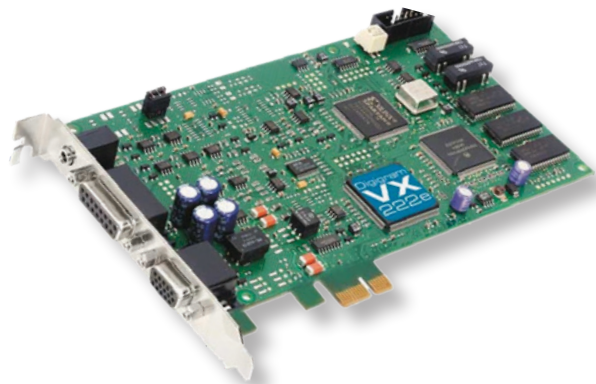

High Quality, Versatile Sound Card

The versatile, high-resolution Digigram VX222HR PCI sound card brings outstanding audio quality and reliability to applications such as broadcast, post-production, music production and live performance. The HR (High Resolution) series is the new industry standard for the most demanding pro audio applications. State of the art sound quality, more features, more processing power, and greater flexibility for custom developments make this new generation of sound cards a top choice for audio professionals. The VX222E is a PCI Express version.

- 2/2 balanced analog and digital AES/EBU I/Os
- Comprehensive set of drivers including Digigram SDK as well as low-latency WDM DirectSound, ASIO, and Wave
- 32-bit/66 MHz PCI Master mode, PCI and PCI-X compatible interface
- 24-bit/192kHz AD/DA converters
- +24 dBu maximum analog signal levels
- 3-band parametric EQ and maximizer
- LTC and inter-board synchronization inputs

VX222E	PCI Express version	List \$662.00*
--------	---------------------	----------------

*Prices too low to advertise. Call BSW for the lowest price 1-800-426-8434.



PCIe Card Boasts Digital Mixer For Extensive Routing

The Digigram LoLa280 is a low-latency, low profile PCI Express multichannel sound card designed for broadcast audio recording and logging systems. Offering 24-bit/192 kHz conversion, it boasts eight balanced analog inputs (each with independent automatic gain control), two balanced analog outputs, a headphone output for monitoring, and an integrated hardware digital mixer for extensive routing options.

LOLA280	List \$999.00*
---------	----------------

*Prices too low to advertise. Call BSW for the lowest price 1-800-426-8434.



Soundcards for Demanding Jobs

The Digigram VX882HR multichannel linear sound card is designed for demanding applications in broadcast such as production, on-air and logging and offers 8/8 analog plus digital I/O. The VX882E is a PCI Express version. The VX442E PCI Express card sports 4/4 analog plus digital I/O and is great for applications requiring two stereo inputs and outputs.

VX882E	PCIe version	List \$2,880.00*
VX881E	8/8 digital, PCIe	List \$2,100.00

*Prices too low to advertise. Call BSW for the lowest price 1-800-426-8434.



IYO-DANTE-32.32M

BSW
CUSTOMER
FAVORITE



More online!
Scan for full specs.



Flexible PCI Express Cards for Broadcast Applications

The ASI5810 and 5811 PCI Express cards offer 2 stereo record streams and 4 stereo play streams. THE ASI5812 is a professional PCI Express audio adapter for radio broadcast FM MPX generation. When on-board compression is not needed, the ASI5700 series provides multichannel playback and record. Both balanced analog and AES/EBU I/O are offered.

ASI5810	4 play/1 out	List \$774.00*
ASI5811	4 play/1 out	List \$954.00
ASI5720	6 play/2 out	List \$1,194.00
ASI5722	6 play/2 out	List \$2,034.00
ASI5740	12 play/4 out	List \$1,674.00
ASI5741	12 play/4 out	List \$1,674.00
ASI5744	12 play/4 out	List \$2,994.00

*Prices too low to advertise. Call BSW for the lowest price 1-800-426-8434.



ASI5810



Up to Eight Channels of Simultaneous Audio/Data Capture

AudioScience ASI8821 professional PCI tuner adapters are designed for use in AM/FM/RBDS/RDS radio broadcast audio monitoring and auditing. Up to eight different channels of AM or FM can be received and recorded simultaneously from a single antenna input. Recording formats include PCM and MPEG-1 layer2 and MPEG-1 Layer 3 (MP3). -5000 and -5500 cards support HD Radio and DAB/DAB+.

ASI8821-1100	8 AM/FM Tuners with RDS	List \$3,594.00*
ASI8821-1000	4 AM/FM Tuners with RDS	List \$2,394.00
ASI8821-2200	8 AM/FM Tuners with RDS	List \$4,314.00
ASI8821-2000	4 AM/FM Tuners with RDS	List \$2,754.00
ASI8821-5500	8 channels of HD-Radio/DAB/DAB+	List \$3,594.00
ASI8821-5000	4 channels of HD-Radio/DAB/DAB+	List \$2,394.00

*Prices too low to advertise. Call BSW for the lowest price 1-800-426-8434.

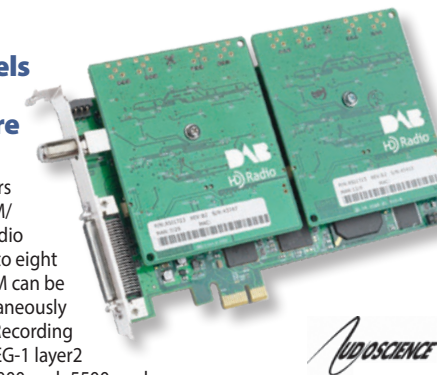

AudioScience IYO-DANTE

The Iyo Dante® is a cost-effective family of microphone/line Dante audio-over-IP (AoIP) interfaces in a 1U rack mount format. Several models provide various configurations of balanced analog audio inputs and outputs.

IYO-DANTE-8.8MR	8 in 8 out mic/line	List \$2,154.00*
IYO-DANTE-16.16MR	16 in 16 out mic/line	List \$3,114.00
IYO-DANTE-16.0MR	16 in 0 out mic/line	List \$2,394.00
IYO-DANTE-0.16LR	0 in 16 out line	List \$2,274.00
IYO-DANTE-32.32MR	32 in 32 out mic/line	List \$4,314.00
IYO-DANTE-32.0MR	32 in 0 out mic/line	List \$3,474.00
IYO-DANTE-0.32LR	0 in 32 out line	List \$3,234.00

*Prices too low to advertise. Call BSW for the lowest price 1-800-426-8434.

CobraNet Sound Cards, Modules and Interfaces

The ASI6416, ASI54xx, and ASI6316 allow multiple streams of audio to be played and recorded to/from a CobraNet network. The ASI2416 allows audio equipment to be interfaced to the CobraNet network. It can be configured with ASI14xx analog and/or AES/EBU or GPIO I/O modules.

ASI6416	16 play/16 record	List \$1,695.00*
ASI1431	8 record, 8 play	List \$834.00
ASI1432	8 Analog in Module	List \$714.00
ASI1433	8 Analog in Module	List \$714.00
ASI1441	AES/EBU Module 4 record, 4 play	List \$834.00
ASI1442	4 AES/EBU in (8 ch) Module	List \$714.00
ASI1443	4 AES/EBU out (8 ch) Module	List \$714.00
ASI1451	GPIO Module	List \$714.00
ASI1462	8 mic pre-amplifiers/line inputs	List \$834.00

*Prices too low to advertise. Call BSW for the lowest price 1-800-426-8434.



ASI6416

Broadcast-Ready Sound Cards

The AudioScience ASI6700 series utilizes the PCI Express interface for faster bus speeds and compatibility with the latest systems. Cards offer up to 24 stereo streams of playback into up to 8 stereo outputs and up to 8 stereo streams of record from up to 4 stereo inputs. Formats include PCM, MPEG layer 2 and MP3 with sample rates to 96kHz.

ASI6714	8 play/4 out	List \$3,798.00*
ASI6718	8/16 play/8 out	List \$4,158.00
ASI6720	4/6 play/2 out	List \$1,314.00
ASI6722	4/6 play/2 out	List \$2,895.00
ASI6740	4 play/4 out	List \$2,034.00
ASI6744	12 play/4 out	List \$4,158.00
ASI6788	16/24 play/8 out, with BOB1038	List \$4,758.00

*Prices too low to advertise. Call BSW for the lowest price 1-800-426-8434.



ASI6788



BOB BREAKOUT BOXES AND CABLES CAN BE ADDED FOR AN EXTRA CHARGE.



YT5080



More online!
Scan for full specs.

Ideal Reporter's Mic/Recorder

The Yellowtec iXm reporter's microphone features an integrated recorder and a choice of interchangeable mic capsules (Premium Line by Beyerdynamic, Pro Line by Yellowtec) in omnidirectional, cardioid and supercardioid patterns. Its innovative LEA engine processor ensures perfect auto leveling in any environment.

The iXm comes with a Yellowtec windscreen, accessory pouch, SD Cards + SD-Card Readers and the Uplink App for iOS devices.

YT5210	iXm Bundle with Omni-directional PREMIUM Line Head	List—\$1,158.00	\$1,088.52
YT5220	iXm Bundle with Cardioid PREMIUM Line Head	List—\$1,158.00	\$1,088.52
YT5230	iXm Bundle with Supercardioid PREMIUM Line Head	List—\$1,158.00	\$1,088.52
YT5250	iXm Bundle with Cardioid PRO Line Head	List—\$906.00	\$851.64
YT5260	iXm Bundle with Supercardioid PRO Line Head	List—\$906.00	\$851.64
YT5080	iXm PODCASTER with Pro Head with Cardioid pattern	List—\$694.00	\$652.36



YT5250



BSW
CUSTOMER
FAVORITE

BSW is the Place to Go for On-the-Go Digital Recording

High-Res Multi-Track Handheld Recorders

TASCAM's Portacapture X8 combines high-resolution sound quality with intuitive app-like control for fast and easy recording. Advanced 32-bit floating point recording lets you capture the most dynamic sound sources without worrying about clipping from loud sources or indistinct audio from quiet sources. Powerful onboard DSP allows you to optimize your recordings right from the Portacapture X8, eliminating the need to transfer to your computer for basic tweaks such as EQ, noise filtering, and normalization. The Portacapture X6 offers the same great performance, but with fewer tracks and inputs.

- HDDA (High Definition Discrete Architecture) mic preamps
- 32-bit float point recording - no need to set gain levels
- Portacapture X8: records 8 tracks (6 track + 2 mix) simultaneously
- Portacapture X8: four XLR/TRS MIC/LINE inputs; dual detachable mics
- Portacapture X8: 3.5" color touch panel display
- Portacapture X6: records 6 tracks (4 track + 2 mix) simultaneously
- Portacapture X6: two XLR inputs and dual built-in mics; 2.4" touchscreen

PORTACAPTURE-X8	List—\$499.00	\$319.00
PORTACAPTURE-X6	List—\$699.00	\$419.00

Hear for yourself how TASCAM continues to push the boundaries of portable recording!



PORTACAPTURE-X8



NEW

Wireless Handheld Condenser Microphone

Broadcast-quality handheld wireless microphone that's ideal for capturing professional audio in a wide range of content creation, media and broadcast applications. It pairs seamlessly with all RØDE Series IV wireless receivers, utilising state-of-the-art 2.4GHz digital transmission to deliver incredibly stable audio with a range of up to 200m (line of sight). Featuring a high-quality omnidirectional condenser capsule, 32-bit float on-board recording, and intelligent GainAssist technology, it delivers professional results in any recording scenario.

INTERVIEW-PRO	Wireless Handheld Condenser Microphone	List—\$399.00	\$242.08
---------------	----------------------------------------	---------------	-----------------



Perfect for Capturing Audio for Video

The TASCAM DR-10L Pro portable recorder with clip-on microphone is a simple and stealthy solution for capturing audio for video. Its 32-bit float recording technology gives you impeccable fidelity, ultra-low noise and no need to fine-tune gain levels.

- Field recorder with lavalier mic ideal for videographers
- Ultra-lightweight, compact and wearable design
- 32-bit float recording and dual AD converter technology
- Automatic leveling and limiting prevent distortion caused by overloads
- Support for microSDXC cards up to 512GB
- Easy-to-read organic EL display
- Headphone output
- USB-C port for easy data exchange with computers
- Records at least 24.5 hours on two lithium AAA batteries

DR-10L-PRO	List—\$199.00	\$149.00
------------	---------------	-----------------



Multi-Track Field Recorder with High Dynamic Range

This Zoom audio recorder offers high-resolution recording to SD with high dynamic range.

- High-resolution multi-track audio recording to SD media
- High-quality mic preamps with up to 75 dB gain
- Locking Neutrik XLR connectors
- Dedicated headphone output with volume control
- AutoMix software automatically adjusts levels
- Ultra-accurate time code
- Advanced look-ahead hybrid limiters
- Doubles as USB audio interface

F6-ZOOM	6 inputs, 14 tracks
---------	---------------------



Feature-Packed Handheld SD Recorder

The TASCAM DR-05X records in MP3 or WAV format to microSD or microSDHC media with a pair of high quality built-in condenser mics. The DR-40X offers adjustable built-in mics, balanced XLR inputs and extended battery life. Both units feature a studio-quality 2 in/2 out USB audio interface ideal for live streaming, podcasting, and digital audio workstations.

- Up to 96kHz/24-bit WAV recording
- Stereo MP3 recording from 32-320 kbps bit rate
- Limiter and low-cut filter to help prevent distortion

DR-05X	Stereo recorder	List—\$219.00	\$99.00
DR-40X	4-track recorder	List—\$299.99	\$199.00



DR-05X

BSW
CUSTOMER
FAVORITE



Go Portable!



H5



H4N-PRO-BLK



Loaded 6-Channel Portable Recorder

The all-black version of the Zoom H6 offers four interchangeable input capsules and six tracks of simultaneous recording to SD, SDHC and SDXC cards (up to 128GB). Its advanced preamps give it impeccable sound quality.

- H5:**
- Records directly to SD, SDHC and SDXC cards up
 - Built-in effects, including low-cut filtering,

- H6-ALLBLACK:**
- 4 interchangeable input capsules: X/Y, MS, Shotgun and dual XLR/TRS combo

- APH-6:**
- Gain controls and -20dB pads for each input
 - Phantom power for all main inputs

- EXH-6:**
- Optional dual XLR/TRS Combo capsule for the H6
 - Connect up to six discrete signals from external microphones, instruments, mixers or portable music players

- SHG-6:**
- Optional hyper-directional shotgun capsule for the H6
 - Ideal for film, video, live theater and ENG applications

H5	4ch Handheld Recorder	\$249.99
H4N-PRO-BLK	Multi-track field recorder	\$199.99
H8	Handy Recorder	\$399.99
EXH-6	H6 Dual XLR/TRS capsule	\$89.99
SHG-6	H6 Shotgun mic capsule	\$149.99
H2N	Portable Recorder	\$179.99



H4-ESSENTIAL

H6-ESSENTIAL

H1-ESSENTIAL



Zoom Essential Series with 32-Bit Float Recording

Zoom's Essential Series is the next generation of three classic recorders, the Zoom H1, H4, and H6. The new recorders offer the same general ports and features of the ultra-popular earlier models, but add 32-bit float recording capability, eliminating the need to monitor and adjust gain levels. All three models sport new screens, record on a single microSDXC card (up to 1TB), and can be powered by an included AC adapter, USB-C, or batteries. They also boast an audible menu for the visually impaired.

- 32-bit float recording (no need to set gain)
- Mic/Line inputs and built-in X/Y microphones
- OLED screen (H1); color LCD screen (H4 and H6)

H6-ESSENTIAL	Six-channel digital recorder	\$299.99
H4-ESSENTIAL	Four-channel digital recorder	\$199.99
H1-ESSENTIAL	Single-channel digital recorder	\$99.99



NEW



New Must-Have Handy Recorder

The ultra-compact Zoom H1 XLR two-track 32-bit float recorder features dual A/D converters, 2 XLR/TRS combo inputs with locking connectors, a MIC/LINE input level select switch for each input, a 32-bit float audio interface for PC, Mac, iOS, and Android devices via USB-C port, microSD recording and more. It offers consistently clear audio, plenty of editing flexibility, and an ultra-high dynamic range that eliminates the need to manually adjust gain.

H1-XLR	Portable Digital Recorder with 32-bit float	\$149.00
---------------	---------------------------------------------	-----------------



Fully Loaded Professional CD Recorder/Player

The TASCAM CD-RW900SX CD recorder/player is chock-full of professional features. As a CD recorder, it offers final mastering, dubbing from any external source, audio archiving and more. As a CD player, it provides music and dialog playback for industrial facilities, retail and business applications, house of worship, retail environments and more.

- Independent input level controls
- Automatic track division (level, time or manual)
- Gapless continuous recording: sync recording function;
- Auto cue, Auto ready
- Power on play
- Supported media: CD-R, CD-R-DA, CD-RW, CD-RW-DA
- RCA analog unbalanced I/O
- COAXIAL and OPTICAL digital I/O
- Four playback modes (continuous, single, program, random)
- MP3 file playback (data-CD)
- Shockproof memory (4 seconds)
- Wireless remote control unit included



More online!
Scan for full specs.

CD-RW900SX	Balanced outputs	List-\$799.00	\$499.00
-------------------	------------------	---------------	-----------------



SS-R250N



Advanced Recorder/Players

TASCAM's SS-R250N is a networkable solid-state recorder/player with a variety of remote control options for professional applications. It records in WAV and MP3 format to SD/SDHC/SDXC and USB flash memory. The SS-CDR250N adds CD recording/playing capabilities via a slot-loading drive.

- Recording and playback of high-resolution files up to 96 kHz / 24 bit
- FTP client function enables automatic uploading of recorded files or downloading audio files from the server
- Event lists for recording, playback, download and more; automatic operation based on set time
- iOS/Android control app for transport operations and remote control of various settings

SS-R250N	Solid state recorder with networking and dual SD card	List-\$1,299.00	\$999.00
SS-CDR250N	Solid state recorder with networking and dual SD, CDR	List-\$1,499.00	\$1,199.00



Dual Cassette Deck with Digital Conversion

The TASCAM 202mkVII dual cassette deck supports recording and playback of normal tapes (Type I) and chrome tapes (Type II), and supports playback for metal tapes (Type IV). Its convenient USB output provides easy digital archiving of your analog tapes.

- Dual cassette deck for playing, dubbing, recording one or two cassettes
- USB output for archiving a cassette to an external digital recorder
- Microphone input with level control can be mixed with cassette One and total mix recorded to cassette Two

202MKVII		List-\$799.00	\$599.00
-----------------	--	---------------	-----------------

PRO AUDIO - CD PLAYERS/ DIGITAL RECORDING

Audio players keep getting more versatile and portable recorders keep getting more indispensable. Check out the latest models (and some time-tested favorites) here.

BUT WAIT... THERE'S MORE
AT BSWUSA.COM!

Professional Recorders and Players

Video Switching, Mixing & More!



More online!
Scan for full specs.



Mega Media Player

CAD Audio's rack-mountable Astatic MP200 multi-function media player can play video from DVD or USB (MP4 up to 1080p), and audio from CD/MP3, USB, or Bluetooth. It also boasts an AM/FM tuner. It offers HDMI, Coax, S-Video and RCA video output, and RCA or balanced XLR audio outputs. CD playback supports CD-ROM, CD-DA, CDR CD-RW, WMA CD and MP3 CD files.

- AM/FM Tuner; CD, MP3, USB, and Bluetooth audio playback
- DVD and USB (MP4) video playback with HDMI and RCA video outputs
- 2 channels of RCA or balanced XLR outputs (1 channel audio, 1 channel video)
- Includes Multifunction RF remote control

MP200 **\$449⁹⁹**



All-In-One Portable Production Studio

Roland's VR-4HD boasts a digital audio mixer, video switcher, multi-viewer touch screen and USB video/audio streaming interface in one compact, portable package. Switching and mixing sound and video is smooth and easy thanks to advanced video and audio DSP, along with dedicated hardware controls and a touch screen interface.

- Integrated touch screen preview monitor
- 6 input, 4-channel video switcher
- 18-channel digital audio mixer with XLR, TRS, and RCA jacks along with audio from HDMI inputs
- Built-in touch quad-input multi-viewer with audio metering
- USB3.0 Video/Audio output up to 1080/30p
- Supports HDMI, RGB/Component and Composite video inputs up to 1080p

VR-4HD **\$1,499.99**



Most Valuable Player

Denon Professional's DN-500CB plays CD media and offers Bluetooth connectivity, USB playback and more. It also features an RS-232c port on the rear for convenient control via serial command.

- Bluetooth 3.0 pairing to (8) devices
- Slot-loading CD transport
- USB host port for file playback
- 10-button direct track access
- 3.5mm AUX input for playback from portable players
- Balanced (XLR) and unbalanced (RCA) outputs

DN-500CB **\$399⁰⁰**



More online!
Scan for full specs.

Portable Compact Video Switcher

Roland's V-1HD makes it easy to connect and switch video cameras, smart phones, computers and other HDMI video sources with a push of a button or slide of a T-Fader. It supports professional compositing effects such as picture-in-picture and keying allowing for graphic insets, titling and even green screen.

- Support for video cameras, action cameras, smart phones, tablet computers and other HDMI devices
- 4 HDMI inputs
- Supports up to Full HD 1080p
- Easy to use Interface
- Two EFFECTS knobs deliver genuine visual performance
- Full 12-channel audio mixer included

V-1HD HD Video Switcher **\$599.99**
V-1SDI G3 SDI Video Switcher **\$1,554.99**



“It was the perfect shopping experience.”
— haynespk

Compact Live Production Video Streaming Switchers

Blackmagic Design's ATEM Mini is a live production streaming switcher that makes it easy to live stream multi camera productions online via services and software such as YouTube, Facebook Live or even Skype. ATEM SDI gives you the portable design of ATEM Mini, but its SDI connections let you connect advanced broadcast quality cameras and recorders.

- 4 high quality HDMI video inputs for live switching cameras, computers and more
- Built in DVE for exciting picture in picture effects
- Broadcast quality transitions
- Upstream keyers for removing blue and green screen backgrounds
- Downstream keyer for superimposing custom graphics
- Two audio inputs (3.5 mm stereo mini-jack)
- Built-in 2-channel audio mixer with compressor, gate, 6-band parametric EQ and more
- One HDMI program output and one Aux output
- One USB-C output for connecting to video software
- Frame rate and format converters on all HDMI inputs
- Video input re-syncon all HDMI inputs
- Hardware-based real time color space conversion



BMD-SWATEMMINIBPR 4 HDMI inputs, live streaming, recording **\$295.00**
 BMD-SWATEMMINICEXTISO 8 HDMI inputs, live streaming, recording **\$1,295.00**
 BMD-SWATEMMXEP ATEM SDI **\$345.00**
 BMD-SWATEMMXEPBPRISO ATEM SDI Pro ISO **\$795.00**
 BMD-SWATEMMXEPCEXTISO ATEM SDI Extreme ISO 9 **\$1,495.00**



Rack Mount AM/FM Digital Tuner with RDS

The Rolls RS81B is a single rack space Phase Lock Loop digital AM/FM tuner designed for a wide range of professional applications. It can store up to 30 FM and AM stations and features an RDS display, an auto search function, a headphone output and balanced XLR outputs.

- Stores up to 30 FM and AM stations
- RDS display
- Large LCD digital display
- Signal strength LED meter indicator

RS81-B **\$319⁰⁰**



Mixers for the Studio or the Road



SQ7

High-Resolution Digital Mixers

Allen & Heath's SQ Series Digital mixers deliver 96kHz high-resolution audio with ultra-low <0.7ms latency; the platform supports up to 48 channels and 36 buses with 8 stereo FX engines with dedicated return channels for dialing in the perfect sound.

SQ 5: 17 Faders / 6 Layers, 16 onboard preamps, 12 Stereo mixes+LR, 3 Stereo Matrix, 7" capacitive touchscreen.

SQ 6: 25 Faders / 6 Layers, 24 onboard preamps, 12 Stereo mixes+LR, 3 Stereo Matrix, 7" capacitive touchscreen.

SQ 7: 33 Faders / 6 Layers, 32 onboard preamps, 12 Stereo mixes+LR, 3 Stereo Matrix, 7" capacitive touchscreen

- 96kHz FPGA processing
- Support up to 48 Input Channels
- 32x32 USB audio interface
- 64ch I/O Port for audio networking

SQ5	17-Fader digital console	\$3,999.00
SQ6	25-Fader digital console	\$4,999.00
SQ7	33-Fader digital console	\$5,999.00

ALLEN & HEATH

BSW
CUSTOMER
FAVORITE



ZEDI-8

Elegant, Durable, Simple Layout, Great Sound

The Allen & Heath ZED Series of USB mixers is ideal for recording, live sound or studio production. Offering up to 16 mono mic/line inputs and four stereo inputs (ZED 24), high gain, low noise preamps, highly responsive EQ, a USB send and return for PC or Mac recording and more, the series delivers incredible bang for your buck. FX models add a comprehensive effects processor. ZEDI models feature a 4x4 USB interface for hassle-free recording and playback.

- Low noise, high headroom preamps
- Multiband EQ
- Professional faders
- Analog warmth and depth

ZED10	10 inputs, USB	List—\$469.99	\$379.99
ZED10FX	10 inputs, USB, FX processor	List—\$499.99	\$399.99
ZED12FX	12 inputs, USB, FX processor	List—\$899.99	\$729.99
ZED14	14 inputs, USB	List—\$749.99	\$599.99
ZED24	24 inputs, USB, 100 mm faders	List—\$1,399.99	\$1,099.99
ZEDI-8	2 Mic/Line + 2 Stereo	List—\$319.99	\$249.99
ZEDI-10	4 Mono Mic/Line + 2 Stereo	List—\$399.99	\$319.99
ZEDI-10FX	4 Mono Mic/Line + 2 Stereo	List—\$499.99	\$399.99



ZED10FX



QU-PAC-32

Powerful Compact Digital Mixers

Allen & Heath's Qu Series takes compact digital mixing to a new level with innovative design and exceptional functionality. Boasting all the features you'd expect in top shelf mixing consoles, the series delivers incredible audio performance and offers 16-, 24- and 32-channel models to meet your exact needs. Qu Chrome Edition models feature upgraded, high contrast metallic finish controls.

- Responsive touch screen
- Automatic Mic Mixer
- 4 FX engines, iLive FX Library
- USB audio streaming

QU-16C	Chrome, 16 channels	List—\$2,499.99	\$1,999.99
QU-24C	Chrome, 24 channels	List—\$3,799.99	\$2,999.99
QU-32C	Chrome, 32 channels	List—\$4,999.99	\$3,999.99
QU-PAC-32	32ch Rack Mountable Digital Mixing System	List—\$2,499.99	\$1,999.99

QU-16C

Yamaha's Revolutionary DM7 Series

The Latest Advance in Digital Mixing Console Evolution

Yamaha's new DM7 series digital mixing consoles offer an intuitive User Interface, compact design, and a comprehensive suite of powerful features to outperform other mixers in their class in a wide range of audio environments.

The DM7 dual bay console provides 120 mono input mixing channels, 48 mix, 12 matrix and two stereo buses, two 12.1" and one 2.7" multi-touch screens, and 28 faders. It boasts 32-in/16-out analog I/O, 144-in/144-out Dante I/O, two-in/two-out AES/EBU I/O (with sample rate conversion), an 18-in/18-out USB audio interface, redundant power supplies and more.

The DM7C single bay console gives you 72 mono input mixing channels, 48 mix, 12 matrix and two stereo buses, one 12.1" and one 2.7" multi-touch screens, 144-in/144-out Dante I/O, one-out AES/EBU, an 18-in/18-out USB audio interface, redundant power supplies and more. Contact a BSW GearHead or visit BSWUSA.com for complete details on this state-of-the-art digital mixing console series

- Powerful Channel Strip
- Extensive plug-ins and new effects
- Advanced GUI for intuitive control
- Utility screen for streamlined performance
- Advanced Selected Channel View and visible Overview
- DAW Remote for efficient audio production
- Split Mode to use one mixer as if it were two (DM7 only)

DM7	Professional 120-ch Dual Bay Digital Console	List—\$36,000.00 *
DM7-EX	DM7 120-ch Digital Mixer+CTL-DM7 Control Expansion	List—\$42,000.00
DM7C	Professional 72-ch Single Bay Digital Console	List—\$18,000.00
DM7C-EX	DM7C 72-ch Digital Mixer+CTL-DM7 Control Expansion	List—\$24,000.00
CTL-DM7	DM7 Control Expansion	List—\$7,200.00

*Prices too low to advertise. Call BSW for the lowest price 1-800-426-8434.



DM7

YAMAHA

Handy, Intuitive Yamaha Mixers

Yamaha's TF series combines innovative design and the latest touch-screen technology to deliver superior performance and intuitive operation.

- Analog XLR/TRS combo mic/line inputs; analog XLR outputs
- Digital record/playback channels via USB 2.0
- Intuitive user interface optimized for touch panel operation
- Touch and Turn Knob for extra control precision
- Traditional Overview and Selected Channel interfaces
- 1-Knob compression and 1-Knob EQ
- TF StageMix iPad application for wireless mixing

TF1	16-channel	List—\$2,585.00 *
TF3	24-channel	List—\$3,276.00
TF5	32-channel	List—\$3,849.00
TF-RACK	16-channel Rack Mount	List—\$2,100.00

*Prices too low to advertise. Call BSW for the lowest price 1-800-426-8434.



TF1

YAMAHA

NEW



Digital Mixer and Multitrack Recorder

The L-6 offers two combo XLR-1/4" mic/line inputs and four stereo pairs of 1/4" line inputs, as well as four sound pads, two aux sends, and five internal send effects. Each channel offers channel strip controls including Level, Pan, Aux 1, Aux 2, and a 3-band EQ with adjustable mid. Whether you record to an SD card, stream via USB to a computer or iOS mobile device, or do both at the same time, the LiveTrak L-6 gives you up to 6 channels (10 inputs) of simultaneous multitrack recording.

L-6	10-channel ultra-compact digital mixer	\$299.00
------------	----------------------------------------	-----------------

ZOOM

Live Sound Mega Mixer



AH-DLIVE-S3

Powerful, Flexible Digital Mixers

Allen & Heath's flagship dLive digital mixing system features three state-of-the-art control surfaces ideal for professional broadcast, installation and touring applications.

The S7000 is a 36-fader dLive S Class remote control surface with two 12-inch capacitive touchscreens. It can control any Allen & Heath MixRack / Mainframe. You can connect up to four control Surfaces to a single MixRack / Mainframe. 36 faders and 36 rotaries are freely assignable in 6 layers on the surface, for a total of 192 control strips. You can connect the S7000 with a single CAT5e cable or a dual redundant mode Cat5e cable to the Mixrack/Mainframe. Two 128x128 channels option slots are available on the back.

The S3000 features a 12" touchscreen, 20 faders, and six assignable one-knob/one-function rotary controls for at-a-glance visual feedback and immediate tactile command over your mix.

The S5000 offers dual 12" touchscreens, 28 faders, and six assignable one-knob/one-function rotary controls.

S7000 Features:

- Mix and match with any MixRack
- Custom fader layout
- Self-locking Ethercon connectors
- Local I/O and extra DX port
- No noise, fanless design
- Two x 12" Capacitive touchscreen
- Two 128x128 I/O ports for extra audio networking
- 192 Control strips
- 26 User assignable keys

- AH-DLIVE-S3 20 faders, 12" touchscreen *
- AH-DLIVE-S5 28 faders, twin 12" touchscreens
- AH-DLIVE-S7 36 faders, twin 12" touchscreens

Accessories:

- DM32 dLive rack, 32 in/16 out
- DM48 dLive rack, 48 in/24 out
- DM64 dLive rack, 64 in/32 out

*Prices too low to advertise. Call BSW for the lowest price 1-800-426-8434.

ALLEN & HEATH



AH-DLIVE-S7



AH-DLIVE-S5

Magnificent Selection Of Mackie Mixers

NEW



Powerful Digital Wireless Live Sound Mixers

The DL16SE and DL32SE digital mixers delivers 16 and 32 channels of proven DL series mixing in a stage-friendly, rack-mountable design. Loaded with extensive DSP processing, the DL16SE and DL32SE gives you the mixing power to sound great every night. Create stunning multitrack recordings via the 16x16/32x32 USB audio interface and play them back for an effortless virtual sound check. The Master Fader SE app allows intuitive control on up to 20 devices simultaneously, including the ability to digitally recall each and every setting for incredibly fast setup.

- 16/32 Onyx+ preamps (8/16 XLR, 8/16 XLR/TRS combo with 2 Hi-Z)
- 8/10 fully assignable XLR outputs plus headphone output
- Connect to your wireless router and control with Master
- Per-channel EQ, filters, gate, compression and
- 4 stereo FX busses with studio-quality reverbs, delays, chorus and more
- Multitrack 16x16/32x32 USB audio interface for recording and playback

DL16SE	16 channel digital rack mixer	\$899.99
DL32SE	32 channel digital rack mixer	\$1,499.99

MACKIE



More online! Scan for full specs.

BSW CUSTOMER FAVORITE



1202VLZ4

1604VLZ4

Professional Compact Line Mixers

Boasting Mackie's flagship Onyx mic preamps, the VLZ4 mixer series delivers the proven feature set, high-headroom/low-noise design and ultra-rugged construction that Mackie is famous for.

- High-headroom/low-noise design
- Boutique-quality preamps
- Strong RF rejection perfect for broadcast applications
- Phantom power for condenser mics
- High-resolution stereo meters
- Rugged steel chassis with powder-coat finish

802VLZ4	8-channel, 3 mic preamps	\$219.99
1202VLZ4	12-channel, 4 mic preamps	\$329.99
1402VLZ4	14-channel, 6 mic preamps	\$449.99
1642VLZ4	16-channel, 4-bus, 10 mic preamps	\$799.99
1604VLZ4	16-channel, 4-bus, 16 mic preamps	\$1,049.99
2404VLZ4	24-channel, 4-bus, 20 preamps, FX, USB	\$1,349.99
3204VLZ4	32-channel, 4-bus, 28 preamps, FX, USB	\$1,599.99



ONYX12

BSW CUSTOMER FAVORITE



ONYX16

Mixers for Every Venue and Every Budget



More online! Scan for full specs.

Premium Analog Mixers with USB

Mackie's Onyx analog mixers offer 24-bit / 96 kHz multitrack recording, award-winning, high-gain Onyx mic preamps, and an end-to-end ultra-low-noise design to deliver the sound quality professionals demand. They are packed with features including powerful DSP effects, British-style Perkins EQ, full-color display, integrated recording and playback from an SD card and a whole lot more. Call, email or visit our website for full details.

ONYX8	8-channel analog mixer with USB	\$499.99
ONYX12	12-channel version	\$649.99
ONYX16	16-channel version	\$749.99
ONYX24	24-channel version	\$949.99

Take Your Show On The Road With These Great Mixers!



Accessory for REMOTEMIX4, REMOTEMIX2 AND REMOTEMIX3.5:
CN113 4-conductor 3.5 mm headset adapter cable **\$10.50**

JK Audio



Field Mixer, Headphone Amp and Communications Interface in One!

- Four XLR mic inputs with switchable 48V phantom power
- Separate headphone level controls; separate headphone source selection
- PBX handset interface; 2.5 mm cell phone interface
- HD Voice (wide band speech) compatible
- Bluetooth Wireless Technology

REMOTEMIX4 List-\$1,650.00 *

*Prices too low to advertise. Call BSW for the lowest price **1-800-426-8434**.



Great For Sports Remotes and A Whole Lot More

- Three XLR mic jacks
- Three 1/4" headphone jacks with individual level controls
- 3.5 mm Send and Receive jacks
- LED VU meter
- Phone line hybrid with DTMF keypad
- Universal PBX handset interface
- Wired phone headset interface (2.5mm and 3.5mm interfaces)
- Bluetooth wireless technology

REMOTEMIX3.5 List-\$1,450.00 *

*Prices too low to advertise. Call BSW for the lowest price **1-800-426-8434**.



Premium 4-Channel Field Mixer

- 4-channel field mixer AND headphone amp
- Four low-noise, high-headroom active balanced mic inputs
- Individually switchable 48V Phantom Power
- 120 Hz low cut filter
- Four 1/4" headphone jacks with individual source selector and level control
- Phone headset interface with 3.5 mm TRRS plug

REMOTEMIX-X4 List-\$1,375.00 *

*Prices too low to advertise. Call BSW for the lowest price **1-800-426-8434**.



Mic and Headphone Control Center

The easy-to-use Henry Talent Pod announcer's mic and headphone controller excels at sporting events and on-location broadcasts, providing talent with a mix of Local and Return audio for their headphones.

- New electronic switching for noiseless mic on/off and cough functions
- Separate inputs for local and return audio with a volume control for each source
- Active mic preamp with selectable balanced line or mic level outputs
- Can be powered with an external wall transformer (if used with a Henry MultiPhones Master unit or SixMix USB Console, a transformer is not required)

TALENTPOD-II **\$425.00**



Handy Mic and Headphone Controller with Talkback

The Henry Engineering Sports Pod is an announcer's mic/headphone controller and intercom system that's ideal for sporting events, on-location broadcasts or in any studio. It offers active mic audio on/off switching as well as the ability to remotely control the mic.

- Solves the problem of providing talent with a mix of Local and Return (IFB) headphone audio
- Provides duplex off-air communication with a producer or engineer
- Elegantly simple design allows for error-free use by non-technical users
- You can easily link several units with CAT 5 cables for broadcasts with multiple announcers

SPORTSPOD **\$595.00**



Sports Broadcast Audio Control System

Comprehensive audio control system for managing the audio portion of a sporting event video broadcast. When used with Henry Engineering's Sports Pods, the SportsCaster provides integrated management of these audio functions:

- Talent mic audio mixing
- Talent headphone audio distribution
- Talkback/Intercom Mic facility for Producer
- Duplex intercom between Producer and Talent
- Producer headphone audio mixing

SPORTSCASTER **\$1,450.00**

BSW
CUSTOMER
FAVORITE

Broadcast Field Mixer and Much More

JK-Audio's RemoteMix 2 is a two-channel field mixer/headphone amplifier that also boasts a communications interface for remote broadcast, IFB, or a backup audio path. It features a phone line hybrid with keypad along with a wired notebook/cell phone headset interface. All sections are designed to work together, saving setup time and wiring in the field.

- Two XLR mic jacks
- Two 1/4" headphone jacks with individual level controls
- XLR Line Out
- 3.5 mm Send and Receive jacks
- LED VU Meter

REMOTEMIX2 List-\$895.00 *

*Prices too low to advertise. Call BSW for the lowest price **1-800-426-8434**.



More online!
Scan for full specs.

Utility Mixers

Intelligent Digital Desktop Mixers

Simplify your daily audio mixing and stimulate your creativity. Get in touch with uncompromising usability for audio workflows. Be it media, audio production or audio for video: You will discover amazing features and a set of well-thought-out control elements like the revolutionary G-Touch® faders. Simpler and smarter – that's what the three Intellimix models FOCUS, NEO and PRO stand for.

INTELLIMIX-FOCUS	Intellimix Desktop Mixer	List-\$4,299.00	\$4,030.31
INTELLIMIX-2-NEO	Intellimix 2 NEO	List-\$4,690.00 *	
INTELLIMIX2	Intellimix 2 PRO	List-\$5,299.00	

*Prices too low to advertise.

Call BSW for the lowest price **1-800-426-8434**.



NEW

YELLOWTEC



MX54S



RM85



MX410

ROLLS

Handy Rolls Mixers

The Rolls ProMix Plus (MX54S) mixes three XLR mic inputs into two XLR outputs. Each input has switchable phantom power, low cut switch and level control.

- Mixes three microphones and sends to two transformer balanced XLR outputs (MX54S)
- Phantom Power and Low-Cut switches for each mic input
- Battery and AC powered

MX54S	3 Channel mic mixer	List-\$179.00	\$149.00
RM82	8 Channel mic/line mixer	List-\$339.00	\$289.00
RM85	Two Zone mic/line mixer	List-\$459.00	\$409.00
MX410	Field mixer 4 CH w/LED meters	List-\$359.00	\$289.00
MX310	3 Channel mic mixer	List-\$139.00	\$109.00



SCM810

Flexible Automatic Mic Mixers

Shure SCM810 and SCM410 automatic mixers are a quick, easy and effective solution for setting up a multiple-mic room. Using innovative IntelliMix technology, they silently activate only the microphones being addressed and automatically adjust each mic's threshold to changes in background noise. They also maintain a consistent output level no matter how many microphones are activated. For ultimate flexibility, models are available with various connector options.

SCM410	4 CH automatic mic mixer	List-\$1,326.00	\$947.00
SCM810	8 CH automatic mic mixer	List-\$2,384.00	\$1,703.00
SCM268	4 mic inputs	List-\$478.00	\$341.00
SCM262	2 mic, 3 stereo source	List-\$434.00	\$310.00

SHURE
SOUND EXTRAORDINARY

Ultra-Accuracy for Great Mixes



RP5G4

Powered Studio Monitors Deliver Superior Stereo Imaging

KRK RokitG3 two-way powered reference monitors feature a proprietary woofer for clear midrange and tight bass, and a soft dome 1-inch tweeter that delivers extended response up to 35kHz. Class A/B bi-amplification offers high headroom and low distortion.

- Glass aramid composite cone woofer
- Advanced waveguide technology
- HF/LF level controls
- A/B bi-amplification
- Multiple input options (RCA, 1/4" balanced/unbalanced, XLR)

RP5G4	5" Two-way Active Powered Monitor	List \$189.00	\$189.00 EACH
RP7G4	7" Two-way Active Powered Monitor	List \$249.00	\$249.00 EACH
RP8G4	8" Two-way Active Powered Monitor	List \$299.00	\$299.00 EACH



More online!
Scan for full specs.



BSW
CUSTOMER
FAVORITE

305MKII



Highly Responsive Reference Monitors

The next generation JBL 3 MkII series of 2-way powered studio monitors feature the JBL Image Control Waveguide and refined transducers to deliver stunning detail, precise imaging, a wide sweet spot and impressive dynamic range to enhance the critical listening capabilities of any modern workspace.

- Image Control Waveguide for detailed imaging and a broad sweet spot
- Refined transducers for optimized transient response and improved linearity
- Dual integrated, Class-D amplifiers provide 82 or 112 watts of power

305PMKII	5", 2-way (41W LF, 41W HF)	List \$217.00	\$149.00
308PMKII	8", 2-way (56W LF, 56W HF)	List \$362.76	\$249.00



V4S4



Active Monitors Deliver Precise Imaging

KRK's V Series of active 2-way, full range studio reference monitors features custom-designed Kevlar drivers for smooth midrange definition without colorization and pristine high-end with tight, controlled low-end.

- Bi-amped Class-D amplification
- Optimized front ported bass reflex enclosure design
- Mid and High Frequency EQs with 49 DSP EQ presets for superior sonic room/desk correction
- Wide sweet spot and precise imaging

V4S4	4" woofer, 85W	List \$419.00	\$419.00 EACH
V6S4	6.5", 155W	List \$629.00	\$629.00 EACH
V8S4	8", 230W	List \$839.00	\$839.00 EACH

Count on BSW...for Monitors You Can Count on



NEW

CR Series Multimedia Monitor Pairs

Ideal for content creation, video production and more, Mackie CR Series Creative Reference Multimedia Monitors offer studio-quality sound and a sleek, eye-catching design. They sport 3", 4" or 5" woofers and boast a front panel headphone out and volume control with rear panel inputs of balanced 1/4" TRS, 1/8" Stereo, and RCA. High-quality cables are included. Bluetooth-enabled models (BT) give you easy music streamin.

- Professional studio-quality sound
- Great for home studios, content creators, gaming, and more
- Brushed metal front panel
- Distinct outlined design
- Plug and Play
- Choose which side of your desk gets the volume knob with the convenient speaker placement switch
- Convenient front panel volume knob with on/off/volume control
- Plug your smartphone or other source into the 1/8" Aux input and listen instantly
- Front-facing headphone jack auto-defeats speaker output
- Flexible inputs - 1/4", 1/8", and RCA
- Professional-grade components and design for optimized sonic performance
- 50 watts of clean, articulate stereo sound
- 4" polypropylene-coated woofer
- .75" ferrofluid-cooled silk-dome tweeter
- Specially designed waveguide delivers unmatched clarity and sound dispersion at all listening levels
- Custom-tuned rear ports for smooth, even bass extension
- All-wood cabinet provides a natural sonic character superior to low-grade plastic designs
- BT models let you effortlessly pair any Bluetooth enabled device for easy music streaming
- Pro Tools® | First and exclusive plugin collection included
- The Musician Collection includes 23 plugins such as BBD Delay, Eleven Lite, 304E EQ, and 304C Compressor

CR3.5	3.5" Powered Studio Monitors w/ Tone Control	\$99.99 PAIR
CR3.5BT	3.5" Powered Studio Monitors w/ Tone Control and Bluetooth®	\$129.99 PAIR
CR4.5	4.5" Powered Studio Monitors w/ Tone Control	\$129.99 PAIR
CR4.5BT	4.5" Powered Studio Monitors w/ Tone Control and Bluetooth®	\$159.99 PAIR
CR5BT	5.25" Powered Studio Monitors w/ Tone Control and Bluetooth®	\$199.99 PAIR
CR8BT	8" Powered Studio Monitors w/ Tone Control and Bluetooth®	\$279.99 PAIR
CR8SBT	8" Powered Subwoofer w/ Bluetooth®	\$199.99



Renowned Neumann Audio Quality In a Studio Monitor!

The Neumann KH 120 D studio monitor delivers ultra-accurate sound reproduction and excels as a near-field loudspeaker or as a rear loudspeaker in larger multi-channel systems. It features a Mathematically Modeled Dispersion waveguide (MMD), flexible acoustical controls, analog class-AB amplifiers, various input formats (analog and digital) and more.

- Powerful titanium fabric dome
- Low-distortion high-frequency reproduction
- Smooth off-axis response
- Forgiving of diverse acoustical environments
- Composite sandwich cone
- Damping of break-up modes
- Long throw bass driver
- Visit BSWUSA.com for more details

KH120D \$1,250.00





Sound You Can Trust

Premium Desktop PC Sound Bar

Elegantly fitting under your desktop display, the Mackie CR2-X Bar Pro offers room-filling, crystal-clear sound, 1/8" Aux, USB and Bluetooth connectivity along with a headphone output for real flexibility. With its three tone presets, you can tailor it to sound how you want with just the push of a button. Easy to use touch controls for volume and mute plus integrated selectable RGB LED lighting complete your sleek desk look.

CR2-X-BARPRO **\$199.99**

MACKIE



Compact Desktop Speakers Offer Big, Clear Sound

Transform your desktop into a sonic paradise with Mackie's CR2-X Cube desktop speakers, featuring powerful BMR driver technology to deliver incredibly clear, room-filling sound from a compact footprint. They offer a bevy of connection options (USB-C, 1/8" Aux, and Bluetooth 5.0), built-in touch control for easy volume adjustment and mute activation, a headphone output and more. If you want more bass, the built-in subwoofer output makes it easy to connect your favorite subwoofer.

CR2-X-CUBE 5", 70W **\$199.99 PAIR**



**BSW
CUSTOMER
FAVORITE**

Powered Reference Monitors for Challenging Rooms

These HS-Series studio monitors from Yamaha deliver consistently superior sound in the most acoustically challenging spaces. The HS5 boasts a 5" cone woofer and 1" dome tweeter and a 45W LF plus 25W HF bi-amp system. The HS7 is a 2-way bass-reflex nearfield studio monitor with 6.5" cone woofer and 1" dome tweeter. Its 60W LF plus 35W HF bi-amp system offers high-performance 95W power amplification. The HS8 sports an 8" cone woofer and provides 120 watts of power (75W LF / 45W HF). The HS8S is an 8" powered subwoofer (150W) that handles low frequencies down to 22Hz

- 2-way bass-reflex bi-amplified nearfield studio monitors
- ROOM CONTROL and HIGH TRIM response controls
- XLR and TRS phone jack inputs accept balanced or unbalanced signals
- Low Resonance Enclosure Design

HS5	5", 70W	List \$252.00	\$199.99 EACH
HS7	6.5", 90W	List \$466.00	\$349.99 EACH
HS8	8", 120W	List \$572.00	\$398.99 EACH
HS8S	8", 150W Subwoofer	List \$775.00	\$499.99 EACH

YAMAHA



Passive & Powerful Studio Monitors

The passive Control 1 Pro features a professional crossover network coupled with professional drivers making it ideal for near-field audio applications. It offers 150 watts power handling capability with a 5.25" woofer and .75" tweeter.

The CONTROL 5 is a two-way system with a 6-1/2" low frequency speaker and a 1" polycarbonate dome tweeter. It delivers up to 175 watts of power handling.

Rugged and reliable K&M mounts let you mount speakers up to 55 lbs. on walls or ceilings.

CONTROL1-PRO		List \$257.06	\$199.98 PAIR
CONTROLS		List \$528.64	\$410.00 PAIR
24185	Speaker wall mount, 18 lb capacity	List \$65.99	\$52.99
24180	Speaker wall mount, 22 lb capacity	List \$76.99	\$61.99

JBL

Compact, Accurate, Dante Networkable

Fostex 6301N series powered digital monitors feature a 20-watt class D amplifier matched to a 4-inch full range driver to deliver a big, clear sound. The flat panel design helps avoid inadvertent power-off or level change. The 6301DT can play back any two channels of Dante network audio signals.

- Magnetically shielded 4" full-range speaker
- Various input options (6301DT offers Dante)
- Built-in 20-watt power amplifier
- Auto Stand-by mode (compliant to ErP directive) for energy saving)
- Multi-voltage power handling, detachable power cable

6301DT	Unbalanced 1/4" input; Dante digital input	List \$519.99	\$399.99 EACH
6301NB	Unbalanced 1/4" input	List \$369.99	\$279.99 EACH
6301NE	Electronically balanced XLR input	List \$389.99	\$299.99 EACH
6301NX	Transformer balanced XLR input	List \$429.99	\$329.99 EACH
6301ND	Digital AES/EBU input	List \$449.99	\$349.99 EACH



**BSW
CUSTOMER
FAVORITE**

Fostex

Installation Just Got Smarter

Genelec Smart IP two-way active installation speakers (available in white or black) come with Smart IP Manager software that allows installers to configure an almost unlimited number of rooms, zones, loudspeakers and audio channels. The software also provides device discovery, a versatile room EQ tool set, system organization and status monitoring.

Smart IP speakers use PoE to produce superb SPL and acoustic performance, and are fully compatible with both Dante and open streaming standards such as AES67. They are available in black (M) and white (W) finishes. Visit BSWUSA.com for full specs.

The ultra-compact 4410A offers 18 watts (bass) and 18 watts (treble) of efficient Class D amplifier power. It sports one RJ45 AES67 / Dante input.

The 4420A delivers 50 watts (bass) and 50 watts (treble) Class D power and boasts one euroblock analog input and one RJ45 AES67 / Dante input.

The 4430A gives you the same power and inputs as the as the 4420A, but boasts a wider frequency response and a larger woofer.

4410AM	Black, 3" woofer	\$750.00 EACH
4410AW	White, 3" woofer	\$750.00 EACH
4420AW	Black 4-1/8" woofer	\$995.00 EACH
4420AM	White, 4-1/8" woofer	\$995.00 EACH
4430AW	Black 5-1/8" woofer	\$1,150.00 EACH
4430AM	White 5-1/8" woofer	\$1,150.00 EACH



GENELEC

Great Sound For Tight Spaces!

The compact Genelec 8030B is a powerful bi-amplified nearfield 2-way monitor system ideal for project studios, workstations, installations and surround sound monitoring. Its Intelligent Signal Sensing feature reduces power consumption by automatically switching the monitor to standby when no audio signal has been detected for some time. Larger models are available for not so tight spaces. Sold as each.

- **8030B:** 5" LF and 3/4" metal dome HF drivers with 40/40 watts bi-amp power, 58 Hz-20 kHz frequency response and 108 dB SPL peak per pair
- **8040B:** 6.5" LF and 3/4" HF drivers with 90/90 watts bi-amp power, 48 Hz-20 kHz frequency response and 115 dB SPL peak per pair
- **8050B:** 8" LF and 1" HF drivers with 150/120 watts bi-amp power, 38 Hz-20 kHz frequency response and 120 dB SPL peak per pair

1032CPM	10" LF/ 200W & 1" HF/ 150W. Analog & AES/EBU digital input producer finish, 61 lbs.	List \$2,695.00	\$2,475.00
8040BPM	6.5" bi-amplified	List \$1,295.00	\$1,175.00
8050BPM	8" bi-amplified	List \$2,095.00	\$1,895.00
8010APM	3" LF/ 12W & .75" HF/ 12W	List \$395.00	\$350.00
8020DPM	4" LF/ 20W & .75" HF/ 20W	List \$595.00	\$550.00
7040APM	6.5" driver/ 50W, for use with 8010 & 8020 stereo systems only	List \$895.00	\$895.00
8030CP	5" 2-way (50W LF, 50W HF)	List \$795.00	\$695.00
8340APM	6.5" 2-way (90W LF, 90W HF)	List \$1,895.00	\$1,695.00
8330APM	5" 2-way (50W LF, 50W HF)	List \$999.00	\$950.00
8320APM	4" 2-way (50W LF, 50W HF)	List \$695.00	\$725.00



GENELEC



THUMP-1155

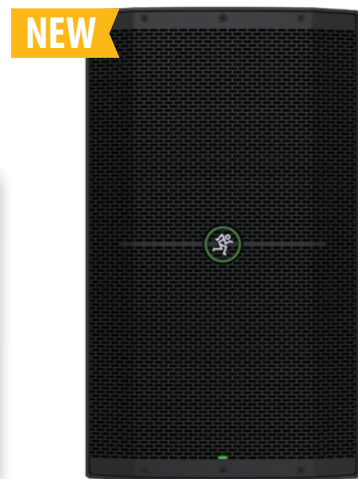

THUMP-212

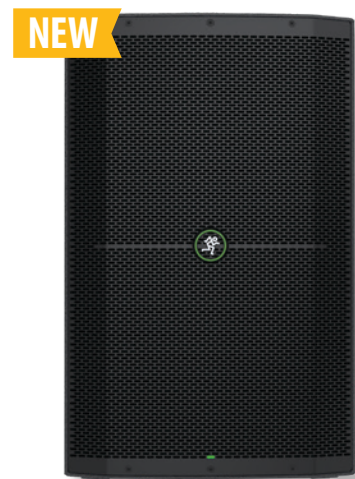

THUMP-215



More online!
Scan for full specs.

Next Generation Thump Series Makes Live Sound Livelier

Mackie's new generation of Thump powered loudspeakers offer powerful clear sound and lightweight portability in a rugged, ergonomic design. Both Thump and ThumpXT models boast a built-in Feedback Eliminator as well as a convenient Music Ducking Mode. ThumpXT models provide extra capabilities with venue-specific voicing modes and supplementary controls via the Thump Connect 2 App. You can access system EQ, levels, mutes, Voicing Modes, and more, and then link the speakers together for Bluetooth® wireless streaming and control.

- 1400W ultra-efficient Class D amplifiers
- Built-in Feedback Eliminator
- Dual TRS/XLR inputs; stereo 1/8" aux input
- Wireless streaming and control via Thump Connect 2 app (enhanced XT versions)

THUMP-212	12" 1400W powered loudspeaker	\$399.99
THUMP-212XT	12" 1400W enhanced powered loudspeaker	\$449.99
THUMP-215	15" 1400W powered loudspeaker	\$449.99
THUMP-215XT	15" 1400W enhanced powered loudspeaker	\$499.99
THUMP-1155	15" 1400W powered subwoofer	\$749.99
THUMP-1185	15" 1400W powered subwoofer	\$849.99

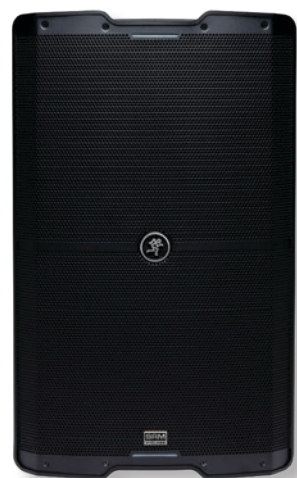

SRM215V

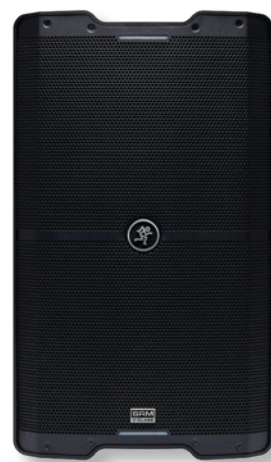

SRM212V



SRM210V



More online!
Scan for full specs.

Mackie's High-Performance SRM Series

Mackie's SRM Series high-performance powered loudspeakers offer superb clarity, output, and control in a sleek, rugged enclosure. Boasting a robust 2000W amplifier with Mackie's Advanced Impulse DSP tuning and Intelligent Bass Management, they deliver accurate, consistent sound quality even at extreme volumes. A built-in digital mixer with full-color display features Bluetooth streaming and powerful processing plus complete wireless control via the SRM Connect app.

- Industry-leading 2000W Class-D amplifier
- High-performance transducers for great sound quality and reliability
- Built-in 4-channel digital mixer with Bluetooth
- Dual independent channels that support mic, line and instrument signals

- Universal power supply (110-240VAC) with Power Factor Correction for consistent performance even with unstable AC power
- Advanced Impulse DSP tuning provides crystal clear sound across the entire dispersion area
- Dedicated limiting/protection processor for maximum stability
- Complete wireless control via the SRM Connect app

SRM210V	10" 2000W High-Performance Powered Loudspeaker	\$749.99
SRM212V	12" 2000W High-Performance Powered Loudspeaker	\$849.99
SRM215V	15" 2000W High-Performance Powered Loudspeaker	\$949.99

Top-Shelf Power Conditioners



F1500-UPS

FRONT

BACK

State-of-the-Art UPS Battery Backup System

Furman's 2RU rackmount F1500-UPS battery backup is designed exclusively for audio/video professionals. Featuring SMP non-sacrificial, zero ground contamination surge suppression technology and EVS Extreme Voltage Shutdown, it's sure to deliver years of trouble free operation.

Today's high-definition technologies have pushed resolution to levels so extreme that virtually any AC noise capable of coupling with your system's signal will distort, mask, or destroy any high-def performance advantages. The F1500-UPS employs exclusive Linear Filtering Technology (LIFT) to four discrete isolated outlet banks to ensure that today's ultra-wide dynamic range stays pristine.

- Input voltage: 85 - 137 VAC
- Input frequency: 47 - 63 Hz
- UPS output voltage: 120 ± 5V True Sine Wave
- UPS output frequency: 60 Hz ± 1%
- UPS output capacity: 1500VA, 900W @ 0.6pf
- Surge Protection: Non-sacrificial SMP (Series Multi-Stage Protection)

F1500-UPS	1500VA rack mount UPS	List—\$1,869.95*
MB850	850VA shelf mount UPS	List—\$419.95

*Prices too low to advertise. Call BSW for the lowest price 1-800-426-8434.



- AC noise filtering to reduce RF and EMI interference
- Powerful spike and surge protection
- Front panel indicator LED

Economical Power Conditioners

Furman Merit X Series power conditioners are the perfect low-cost AC power solution for any rack mount system. Available in three models, each install on the top slot of your rack and offer eight switched outlets to protect all of your equipment up to a 15-amp load.

M8LX	Conditioner w/ light fixtures	List—\$219.95	\$199.95
M8DX	Conditioner w/ lights and meter	List—\$269.95	\$239.95
M8X2	No lights, no meter	List—\$134.95	\$119.95



PLPLUSC

Furman Classic Series

Furman's Classic Series of rack-mountable power conditioners offers superior protection and performance. Furman's revolutionary Series Multi-Stage Protection, Linear Filtering Technology and Extreme Voltage Shutdown ensure the cleanest power possible.

PL8C	15- amp, 9 outlets	List—\$369.95	\$324.95
PLPLUSC	L15- amp, 9 outlets	List—\$439.95	\$399.95
PLPRODMC	W/ voltmeter/anmeter	List—\$799.95	\$669.95
PLPLUSDMC	20-amp, w/ USB charger	List—\$579.95	\$499.95
PLPROC	W/ voltmeter/ammeter	List—\$684.95	\$574.95



More online!
Scan for full specs.

DSP-Controlled Uninterruptible Power Supply (UPS)

The Staco SP series features a field-proven Digital Signal Processor (DSP) achieving high reliability, while providing protection from electrical power disturbances to the connected load. The convertible tower/rack design offers maximum flexibility, enabling UPS integration into a wide variety of environments. Industry-leading functionality is standard and includes hot swappable battery, powerful internal charger, emergency shut-down and programmable receptacles.

- Convertible tower/rackmount design
- Advanced digital control technology
- Wide input voltage and frequency ranges
- Hot swappable battery, built-in charger

SP1000EBC120	1 kVA Battery Pack for 120V System (Compatible with SP1000RT120)	List—\$1,183.75 *
SP1000RT120	Single phase UPS, 1000VA/1000W 120V	List—\$1,106.60
SP1500EBC120	1.5 kVA Battery Pack for 120V System (Compatible with SP1500RT120)	List—\$1,331.25
SP1500RT120	Single phase UPS, 1500VA/1300W 120V, Rack Tower (DOE Compliant)	List—\$1,307.90
SP2000EBC120	2 kVA Battery Pack for 120V System (Compatible with SP2000RT120)	List—\$1,427.50
SP2000RT120	Single phase UPS, 2000VA/1800W 120V, Rack Tower (DOE Compliant)	List—\$1,534.50
SP3000EBC120	3 kVA Battery Pack for 120V System (Compatible with SP3000RT120)	List—\$1,772.50
SP3000RT120	Single phase UPS, 3000VA/2700W 120V, Rack Tower (DOE Compliant)	List—\$2,052.60

Accessories:

SCV-SNMP	SNMP Web Card (Compatible with ALL UPS Above)	List—\$270.00
SC-RAIL	Rail Kit (Compatible with the 1kVA - 3kVA UPS)	List—\$161.84

*Prices too low to advertise. Call BSW for the lowest price 1-800-426-8434.





Affordable Equipment Racks in Black or Oak Finishes

These well-built, inexpensive Middle Atlantic RK Series equipment racks ship flat for easy storage and assemble quickly with the included allen key. Racks are constructed of 5/8" thick, high-density particle board covered with black laminate and are 15-7/8" deep. Rack rails are 1/8" thick enamel steel.

- RK-4** 4-space rack (7"), black List-\$215.00 *
- RK8** 8-space rack (14"), black List-\$248.00
- RK12** 12-space rack (21"), black List-\$272.00
- RK16** 16-space rack (28"), black List-\$285.00
- RK20** 20-space rack (35"), black List-\$307.00
- SRK** 28-space sloped rolling rack, black List-\$647.00

*Prices too low to advertise. Call BSW for the lowest price **1-800-426-8434**.

Portable Rolling Racks

Middle Atlantic's PTRK rolling racks boast welded construction, 500 lb. capacity, 16-gauge steel, smooth-rolling 4" cushion casters and a locking front.

- PTRK14** 14-space/34" List-\$1,194.00 *
- PTRK21** 21-space/46" List-\$1,259.00

*Prices too low to advertise. Call BSW for the lowest price **1-800-426-8434**.



"Good, sturdy rack support."



DR12

12-Space Desktop Rack Rail

This desktop rack unit provides 12 rack spaces for equipment mounting. Racks can secure to desktop with screws.

- DR12** List-\$126.00*

*Prices too low to advertise. Call BSW for the lowest price **1-800-426-8434**.



Great for Large-Scale Multi-Bay Installations

The Middle Atlantic MRK series offers a narrow design for large-scale multi-bay installations, with wider rack rails for more usable room. Available in four outside depths (26.5", 31.5", 36" and 42") and in 24, 37, 40 and 44 space sizes, the racks in this series feature a slim 22" OD width, fully welded construction with open sides and key-locked solid rear doors.

- Seismic rated (UBC Zone 4) for protecting 1000 lbs.
- 2 pairs of wider rackrail provide more interior room
- Laser-cut 1/8" thick internal steel braces for strength
- 14-gauge steel tops and bottoms, 16-gauge seamless steel sides
- Grounding and bonding stud installed in base
- Configurable open top accepts a number of top options

- MRK2426** 24-space (42") 26.5" deep (24" usable) List-\$1,679.00*
- MRK3726** 37-space (64.75") 26.5" deep (24" usable) List-\$1,806.00
- MRK4026** 40-space (70") 26.5" deep (24" usable) List-\$1,871.00
- MRK4426** 44-space (77") 26.5" deep (24" usable) List-\$2,019.00
- MRK4031** 40-space (70") 31.5" deep (29" usable) List-\$2,222.00
- MRK4431** 44-space (77") 31.5" deep (29" usable) List-\$2,325.00
- MRK4036** 40-space (70") 36" deep (33.6" usable) List-\$2,544.00
- MRK4436** 44-space (77") 36" deep (33.6" usable) List-\$2,626.00

*Prices too low to advertise. Call BSW for the lowest price **1-800-426-8434**.



Full-Featured, Low Price Racks

Middle Atlantic's ERK series racks boast unsurpassed features at the lowest price in their class. Fully welded construction combined with 16-gauge steel tops, bottoms and sides provides a 750 lb. capacity.

- ERK4420** 44-space, 81-1/2" rack List-\$1,336.00*
- ERK4020** 40-space, 74-1/2" rack List-\$1,261.00
- ERK35-20** 35-space, 65-3/8" rack List-\$1,126.00
- ERK2720** 27-space, 51-3/8" rack List-\$1,032.00
- ERK2120** 21-space, 40-7/8" rack List-\$972.00

*Prices too low to advertise. Call BSW for the lowest price **1-800-426-8434**.

Build custom racks from Middle Atlantic at middleatlantic.com. Get the best deal through BSW!



Gangable Racks with Rear Door

The Middle Atlantic WRK series equipment racks are fully welded and ideal for large cable bundles.

- **WRK4432**: gangable enclosure multi-bay 44-space rack with a keylocked solid rear door.
- **WRK4032**: same great features in a 40-space size
- **WRK3732**: 37-space version

- WRK4432** 44-space rack List-\$2,426.00*
- WRK4032** 40-space rack List-\$2,328.00
- WRK3732** 37-space rack List-\$2,230.00

(Racks are 32" deep, 30 3/4" usable, front doors and side panels are sold separately. WRK rack, rear door included, not shown)

*Prices too low to advertise. Call BSW for the lowest price **1-800-426-8434**.



Shown with optional oak sides.

Rugged Rack Frame System

The Middle Atlantic Slim 5 features a bolt-together design that ships disassembled, mechanically interlocking corners, 14-gauge steel top and bottom and 2 pairs fixed-position 11-gauge front and rear rack rail.

- 5-43** 43-space, 75.25" rack List-\$745.00*
- 5-37** 37-space, 64.75" rack List-\$714.00
- 5-29** 29-space, 50.75" rack List-\$681.00
- 5-21** 21-space, 36.75" rack List-\$618.00
- 5-14** 14-space, 24.5" rack List-\$550.00

*Prices too low to advertise. Call BSW for the lowest price **1-800-426-8434**.

Interview Mics for Every Location



A. Electro-Voice 635LB C. Electro-Voice RE50NDL E. Electro-Voice 635AB G. Sennheiser MD46 I. Rode Reporter

A. Black, But Far From Basic

The 635L in a classic black finish.

- 635L-B** List-\$226.00 **\$169.00**



B. Long Ranger

The RE50L is a long-handle (9.5") version of the popular Electro-Voice RE50B.

- RE50L** List-\$281.00 **\$209.00**



C. Reach Farther

The high-output RE50N/D-B in a 9.5" long-handle version.

- RE50N-DL** List-\$340.00 **\$229.00**



D. Radio Broadcasters' Favorite for 40 years

The celebrated dynamic mic with voice-tailored response and rugged metal construction.

- 635A** List-\$205.00 **\$159.00**



E. 635A in Black

Same great mic in a black finish.

- 635AB** List-\$205.00 **\$159.00**



F. The Industry Standard RE50

The Electro-Voice dynamic RE50B is an excellent location mic. The RE50N/D-B adds a neodymium magnet structure for increased sensitivity.

- RE50B** List-\$255.00 **\$199.00**
- RE50NDB** List-\$303.00 **\$219.00**



G. Reporter's Mic Thrives in Noisy Conditions

The MD46 is a high-quality reporter's mic that shrugs off pop and wind noise while offering wide frequency response and easy handling.

- MD46** List-\$249.00 **\$199.95**



H. Rugged Interview Mics

This small Shure dynamic omnidirectional interview mic sounds great and is extremely rugged. The VP64AL has a longer (9-5/8") handle.

- VP64A** List-\$119.00 **\$89.00**
- VP64AL** List-\$129.00 **\$99.00**



I. RØDE Reporter

Omnidirectional polar pattern, with multi-layer mesh basket for wind protection.

- REPORTER** 10.7" long **\$129.00**



Lavalier and Headset Microphones from Sennheiser

Sennheiser's MKE Essential Omni lavalier mic series offers a compact, high quality omni directional capsule with an acoustic signature similar to the renowned MKE 2. The HSP Essential Omni headset mic series was developed with valuable input from the House of Worship community. Mics in both series deliver warm, detailed, distortion-free sound with excellent speech intelligibility and are available in black or beige.

- | | | | | | |
|--------------------------|---------------|-----------------|--------------------------|---------------|-----------------|
| MKE-ES-OMNI-BLK | List-\$249.95 | \$199.95 | HSP-ES-OMNI-BLK | List-\$309.95 | \$249.95 |
| MKE-ES-OMNI-BE | List-\$249.95 | \$199.95 | HSP-ES-OMNI-BE | List-\$309.95 | \$249.95 |
| MKE-ES-OMNI-BLK3P | List-\$309.95 | \$249.95 | HSP-ES-OMNI-BLK3P | List-\$369.95 | \$299.95 |
| MKE-ES-OMNI-BE3P | List-\$309.95 | \$249.95 | HSP-ES-OMNI-BE3P | List-\$369.95 | \$299.95 |



MKE-ES-OMNI-BLK

German Engineered Condenser Mics

Versatile Multi-Pattern Condenser

The Neumann TLM 107 large diaphragm condenser mic offers pure, uncolored sound quality, five switchable polar patterns, a wide dynamic range and very low self-noise.

- Switchable omnidirectional, wide angle cardioid, cardioid, hypercardioid and figure-8 polar patterns
- Illuminated pattern display
- 20 Hz - 20 kHz frequency range
- Transformerless circuitry for a high degree of linearity and large dynamic range
- Whopping 141 dB maximum SP
- Slight high frequency boost lends presence and freshness to the voice

TLM107 List \$1,829.00*
TLM107-BLK List \$1,829.00

*Prices too low to advertise.
Call BSW for the lowest price 1-800-426-8434.



TLM107-BLK



BSW CUSTOMER FAVORITE

More online! Scan for full specs.



3 switchable polar patterns for recording flexibility!



BSW CUSTOMER FAVORITE

U87AI

U87AIMT

See the video at bswusa.com/U87AI

Top Studio Mic for Decades

For over 40 years, the Neumann U87 has been coveted by anyone looking to capture audio at the highest possible sound quality. This legendary condenser mic features a large dual-diaphragm capsule with three switchable polar patterns for incredible versatility. And speaking of legends, check out the U47 fet Collectors Edition, complete with high quality wooden case and more.

- Studio classic variable large diaphragm mic
- Pressure-gradient transducer with double membrane capsule
- 3 directional characteristics: omni, cardioid, figure-8
- Switchable low frequency roll-off; switchable 10 dB pre-attenuation
- Set Z includes shockmount, windscreen and cable

U87AIMT Black finish List \$4,129.00*
U87AI Nickel finish List \$4,129.00
U87AIMTSETZ Black Set Z List \$4,629.00
U87AISETZ Nickel Set Z List \$4,629.00
U47FET-CE Collectors Edition List \$5,499.00

Accessories:
EA87 Spider shockmount List \$509.00
WS87 Windscreen List \$79.00

*Prices too low to advertise.
Call BSW for the lowest price 1-800-426-8434.



Condensers with Renowned Neumann Sound

The TLM 103 is essentially the element from the world-famous U87, utilized in a cardioid-only pattern. By using the tried-and-true transformerless circuit found in numerous Neumann microphones, the large diaphragm TLM103 offers low self-noise (7 dBA) and the highest sound pressure level transmission. TLM103 includes a swivel mount and wooden box.

Neumann also offers the TLM103D digital output microphone with built-in A/D converter. The AES/EBU or S/PDIF connection kit is sold separately. Go online for details.

TLM103 Analog out List \$1,499.00*

Accessories:

EA1 Shockmount \$299.00

*Prices too low to advertise.
Call BSW for the lowest price 1-800-426-8434.



BSW CUSTOMER FAVORITE

"Ideal for many broadcast and voice-over applications."



TLM103

Classic Neumann Sound in a Very Compact Package

The TLM 102 large diaphragm condenser microphone boasts a compact size and wallet-friendly price while offering Neumann's usual high quality design components.

- Innovative large-diaphragm cardioid capsule
- Maximum SPL of 144 dB
- Slight boost above 6 kHz for excellent voice presence in the overall mix
- Just over 4 1/2 inches long
- Comes with a stand mount

TLM102 Nickel finish List \$909.00*
TLM102MT Black finish List \$909.00

*Prices too low to advertise.
Call BSW for the lowest price 1-800-426-8434.

See the video at bswusa.com/TLM102



TLM102

TLM102MT

Optimized for Voice

The Neumann TLM 49 is a large-diaphragm studio mic boasting a tight cardioid pattern to keep ambient noise at bay and a warm, natural sound especially optimized for vocal performance. Inspired by Neumann's legendary M 49 microphone, the TLM 49 uses the same acclaimed K 47 capsule to capture the true essence of whatever you're recording.

- Optimized for voice
- Transparent, uncolored sound
- Transformerless circuitry for low self noise
- Easily handles high gain levels
- Shockmount included

TLM49 List \$2,129.00*

*Prices too low to advertise.
Call BSW for the lowest price 1-800-426-8434.



NEW

Loaded Home Recording Microphone

Shure's SM4 captures professional recordings with mix-ready audio and interference protection. The one-inch brass dual-diaphragm capsule offers remarkable accuracy and exceptional low-frequency control, while innovative Interference Shielding Technology blocks unwanted RF noises from wireless devices. Boasting rugged all-metal construction, its low-profile design is just the ticket for your home studio.

SM4-K SM4 Mic, black w/hard mount List \$249.00 \$199.00
SM4-K-KIT SM4 Mic, black, w/ shock mount, case List \$339.00 \$269.00
A4CC SM4 Softshell carrying case List \$25.00 \$20.00
A4EB SM4 Shockmount elastic bands List \$6.00 \$5.00
A4M SM4 Swivel hardmount List \$44.00 \$35.00
A4PF SM4 Magnetic pop filter List \$34.00 \$27.00
A4SM SM4 Shockmount List \$60.00 \$48.00



Makes Any Voice Sound Better

The Shure KSM42 premium side-address, cardioid condenser microphone features a large dual-diaphragm capsule, optimized for world-class vocal recording and performance applications.

- Tailored frequency response
- Extensive internal and external pop filtering
- Single-pattern, dual-diaphragm design
- Prethos Advanced Preamplifier Technology
- Smooth proximity control, ultra-wide dynamic range
- Transparent internal circuitry architecture
- Comes with shock mount, magnetic pop filter, aluminum carrying case, and velveteen pouch

KSM42SG List \$1,099.00 \$849.00



Smooth as Silk Sound

The Shure KSM32SL side-address, cardioid condenser mic has an incredibly smooth sound to go along with its state-of-the-art design.

- Ultra-thin, 1" gold-layered Mylar diaphragm for focused transient response
- 3-position switchable low-frequency filter
- Transformerless transparent preamp
- Switchable 15 dB pad for handling extremely high SPL

KSM32SL List \$819.00 \$649.00

Accessories:

A32WS Windscreen \$11.00



Versatile Multi-Pattern Condenser Mic

Shure's KSM44A is a premium, large-diaphragm, side-address condenser mic with multiple polar pattern options (cardioid, omnidirectional, bidirectional).

- Class A, discrete, transformerless preamp
- Total dynamic range of 127 dB for cleanly nuanced audio
- Dual 1-inch diaphragms provide superior frequency response
- Switchable 15 dB pad for handling high SPL
- 3-position switchable low-frequency filter; subsonic filter

KSM44ASL List \$1,249.00 \$999.00

Accessories:

A32WS Windscreen \$11.00



Excels in Studio, Thrives on the Road

The Shure KSM137/SL is an end-address condenser microphone with a single cardioid polar pattern. Designed for studio use, yet rugged enough for live applications, it can withstand extremely high SPL. It's also available in a matched stereo set.

- Highly consistent cardioid polar pattern
- 24 karat gold-layered, low mass Mylar diaphragm for superior transient response
- Class A, discrete, transformerless preamplifier for transparency
- Switchable 15 dB pad for handling high SPL
- Premium electronic components

KSM137SL List \$439.00 \$349.00

KSM137SL-STEREO List \$879.00 \$699.00



KSM141SL

Switchable Polar Patterns

The Shure KSM141/SL is a dual-pattern end-address condenser mic that allows easy switching between a consistent cardioid or true omnidirectional polar pattern for smooth and focused sound reproduction. It's also available in a matched stereo set.

- Switchable, highly consistent cardioid and true omnidirectional polar patterns
- 24 karat gold-layered, low mass Mylar diaphragm for superior transient response
- Class A, discrete, transformerless preamplifier for transparency

KSM141SL List \$569.00 \$449.00

KSM141SL-STEREO List \$1,129.00 \$899.00

Find what you need. Whenever you need it.

BSWUSA.COM



BSW is Your Virtual Mic Locker – Incredible Selection AND Expert Advice!



BSW CUSTOMER FAVORITE

Great-Sounding Condenser Mics

The Sennheiser MK4 large-diaphragm studio microphone features a 1-inch true condenser capsule and delivers excellent sound quality. The MK8 offers five switchable polar patterns.

- One-inch large-diaphragm capsule
- Low self-noise and maximum SPL
- 5 polar patterns (MK8)

MK4 \$299.95
MK8 \$699.00



24-carat gold-plated diaphragm!

Advanced Condenser Microphone

Audio-Technica's AT4040 side-address condenser mic offers smooth, natural sonic characteristics with a wide dynamic range and low noise.

- Focused cardioid pattern
- Switchable 80 Hz high pass filter and 10 dB pad
- Transformerless circuitry virtually eliminates low-frequency distortion

AT4040 \$299.00



High End Features, Low End Price

Audio-Technica's budget friendly AT2020 condenser offers many of the high-end features found in their 4000 series mics.

- High SPL handling and wide dynamic range
- Custom-engineered low-mass diaphragm
- Extended frequency response and superior transient response
- Pivoting, threaded stand mount for easy and precise mic placement

AT2020 \$99.00



BSW CUSTOMER FAVORITE

Matched Pair Of Premium Condenser Mics

Get a matched pair of RØDE's M5 pencil-style cardioid condenser microphones offering low noise performance and full frequency response.

- Half-inch capsule with gold-plated membrane
- Cardioid polar pattern
- Ultra-low noise transformerless circuitry
- State-of-the-art surface mount electronics
- Gold plated output connector
- Heavy-duty black matte finish
- Includes mic clips and windshields
- 10-year warranty

M5-MP \$199.00



Great-Sounding Valve Microphone

The RØDE NTK is a tube/valve microphone featuring a large one-inch capsule with gold-plated membrane and twin triode valves for wide dynamic range with ultra-low noise.

- Large capsule (1") with gold-plated diaphragm
- Class A valve circuitry
- Hand selected and graded 6922 twin-triode valve
- Dedicated power supply
- 10-year warranty

NTK \$529.00



Industry-Favorite Hybrid Mic



MV7-PLUS-W



NEW

MV7-PLUS-K

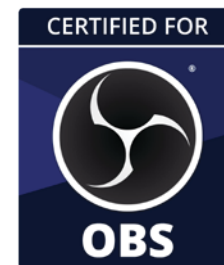

Broadcast-Quality Audio in the Most Challenging Spaces

Ideal for broadcasting, podcasting, streaming and more, the Shure MV7+ Podcast Microphone captures broadcast-quality audio in even the most challenging of spaces. It boasts a customizable LED touch panel, powerful DSP, and even better audio quality. This updated dynamic mic offers USB-C and XLR outputs, an improved Auto Level Mode, as well as a new digital pop filter, real-time Denoiser and reverb effects. It's available in black (K) and white (W) finishes. The MV7X is a budget friendly version with just an XLR output.

- Voice Isolation Technology separates your voice from unwanted background sounds
- Certified by the Open Broadcaster Software (OBS) Project for high-quality streaming with OBS
- Auto Level Mode adjusts your mic's gain based on distance, volume and spatial detection
- Real-time Denoiser uses cutting-edge DSP technology to eliminate ambient noise in your room
- New Digital Popper Stopper™ removes harsh plosive sounds
- Free MOTIV Mix™ Desktop App for configuring the LED touch panel from 16.8 million color options
- Use the app to optimize mic settings like sound signature, gain and much more
- Instantly mute the microphone by tapping anywhere on the LED panel
- Monitor your audio in real-time via the 3.5mm headphone jack

MV6 List \$186.00 \$149.00
MV7-PLUS-K List \$349.00 \$279.00
MV7-PLUS-W List \$349.00 \$279.00
MV7X List \$224.00 \$179.00



More online! Scan for full specs.



MV6

Start-up or Serious Podcaster—BSW Has the Gear for You!



BSW
CUSTOMER
FAVORITE

High Quality Dynamic USB Microphone

The RØDE Podcaster is a dynamic, end-address USB microphone combining broadcast quality audio with the ease of USB connectivity for recording directly to a computer without an additional digital interface. Featuring a tight cardioid pattern for focused audio capture with superior off-axis sound rejection, it's ideal for any production application requiring a simple yet professional voice-over mic.

PODCASTER **\$229.00**

RØDE



NEW

Super-Versatile Dynamic USB Mic

The PreSonus Revelator Dynamic USB microphone offers the clarity and warmth of the fan-favorite PD-70 mic and adds easy-to-use, customizable presets to take virtually any voice to even high levels. Its custom-built microphone capsule captures your voice cleanly and clearly, with superior off-axis rejection that enables you to set up your broadcast or recording studio in just about any space. It also boasts an integrated mixer with two dedicated loopback audio channels to add backing tracks, Skype calls, gameplay audio, and more.

REVELATOR-DYN **\$199.99**

PreSonus



Revolutionary Hybrid Studio Condenser Mic

Relegate signal clipping to the dustbin of history with RØDE's NT1 5th Generation XLR/USB large diaphragm cardioid studio condenser mic. It features a groundbreaking Dual Connect output offering both XLR and USB connectivity for serious versatility, an unclippable 32-bit float digital output, ultra-high-resolution (up to 192kHz) analog-to-digital conversion, advanced digital signal processing and more while delivering a warm, silky character, extremely low noise, and high SPL handling.

NT1GEN5B List \$399.00 **\$249.00**

RØDE



Perfect for Podcasting, Streaming, Recording and More

Audio-Technica's great-sounding, easy-to-use AT2020USB-X cardioid condenser USB microphone boasts a built-in headphone jack with volume control for direct monitoring of the mic signal with no delay.

- Hassle-free plug and play operation
- High resolution A/D converter
- Mix control for blending the mic's audio with audio from the computer

AT2020USB-X **\$129.00**

audio-technica

“BSW is always ready to help!”

— robert-89110, resellerratings.com

Cool USB/XLR Hybrid Mics & More

Ultra-Versatile Dynamic Hybrid Microphone

The RØDE PodMic USB delivers broadcast-quality voice capture for a wide variety of applications, including podcasting, content creation, video production, streaming and more. Incredibly flexible, it offers both XLR and USB connectivity for connecting to an audio interface or mixer, or directly to a computer for plug-and-play recording.

PODMIC-USB List \$299.00 **\$199.00**
PODMICW-USB List \$299.00 **\$199.00**

This versatile broadcast mic is a high-quality portable podcasting and streaming solution!



PODMICW-USB



NEW

RØDE



PODMIC-USB



BSW
CUSTOMER
FAVORITE

IRIG-MICLAV2P-IN

Lavalier Mic Works With All Devices

IK Multimedia's iRig Mic Lavalier is a compact professional-quality mobile lavalier mic for iPhone, iPad, iPod Touch and Android.

- Omnidirectional condenser capsule
- Comes with a suite of powerful recording apps
- Includes foam pop shield and durable mounting clip

IRIG-MICLAV-IN Lavalier for devices **\$49.99**
IRIG-MICLAV2P-IN 2-pack **\$99.99**

IK

CAN'T FIND WHAT YOU'RE LOOKING FOR?

BSWUSA.COM has thousands of products beyond what's in the catalog. Chances are if you need it, we have it. We can even do the research for you... contact a BSW GearHead at 800.426.8434.

Search



Industry-Favorite Broadcast Microphones



NEW

Wireless Lavalier System Ideal for Content Creators

Shure's new MoveMic One and MoveMic Two are single- and dual-channel wireless clip-on microphones perfect for mobile content creators, videographers and journalists. Pairing directly to your smartphone and providing up to 24 hours of recording on the go, this modern take on the lavalier microphone combines a compact form factor with speedy setup and superb audio quality.

The MoveMic Receiver works as an additional accessory to boost the compatibility of your MoveMic One or MoveMic Two system to include DSLR/mirrorless cameras, computers, and third-party mobile apps.

- One or two channels of broadcast-quality audio transmits directly to your iOS or Android phone
- Eight hours of battery life in the microphone, with an additional two full charges ready in included carrying case
- MoveMic Receiver (MVR-R-Z7) adds compatibility with DSLR and mirrorless cameras, computers and more
- Get MV-TWO and MV-R in money-saving kit (MV-TWO-KIT-Z7)

MV-ONE-Z7	List \$311.00	\$249.00
MV-TWO-Z7	List \$436.00	\$349.00
MV-TWO-KIT-Z7	List \$624.00	\$499.00
MV-R-Z7	List \$249.00	\$199.00



Wireless Mic System

Wireless-GO is the world's smallest, most versatile wireless microphone system. Professional and easy for an all-in-one run and gun setup.

- Dual-channel wireless mic system
- 2.4 GHz digital frequency
- 3.5mm TRS output, USB-C and iOS compatible digital audio output

WIRELESS-GOII Dual-channel wireless system **\$299.00**



Studio-Quality USB Microphone

NT-USB Mini is a compact, studio-quality USB microphone designed for recording direct to a computer or tablet. It is simple to set-up and use, and a smooth frequency response and directional pickup pattern make the NT-USB Mini perfect for recording vocals and instruments, livestreaming and gaming, podcasting, voice calls and more.

NT-USB-MINI **\$99.00**



RØDE

Ideal for Content Creators

Audio-Technica's AT2020USB-X cardioid condenser USB microphone offers extremely clear, natural sound reproduction thanks to its high-resolution A/D convertor (up to 24-bit/96 kHz sampling rate). Its smooth, extended frequency response is ideally suited for streaming, podcasting, video production and more.

AT2020USB-X **\$129.00**



MOTIV XLR to USB Adapter

Easily connect any XLR microphone directly to your computer with the MVX2U. Ready to record or stream right out of the box with any dynamic or condenser microphone, this compact XLR-to-USB audio interface is perfect for podcasters, creators and musicians wanting to upgrade their sound with onboard DSP using the free ShurePlus™ MOTIV Desktop App.

MVX2U List \$161.00 **\$129.00**



NEW

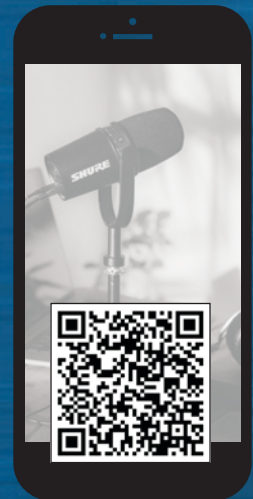

Want the latest on BSW USB Mics? Scan this code for the complete story.



Replacement/Spare Charge Case

The AMV-CHARGE is a replacement/spare charge case for MoveMic lavalier microphones. It delivers up to 24 hours of on-the-go recording.

AMV-CHARGE List \$149.00 **\$119.00**

Join the Advantage Club: VIP discounts, a personal rep, and effortless buying—because you're too important for ordinary.

800.426.8434

Bryan Seeley, GearHead
BryanS@bswusa.com





NXN8C



NXN8S

Innovative Dynamic Mic with Dual Transducers

Shure's Nexadyne 8/C is a cardioid dynamic microphone for professional live vocal performance, featuring patented Shure Revonic dual-engine transducer technology. Its clean and natural cardioid pickup pattern allows vocals to easily reach every corner of the venue. It includes a mic clip and carrying case.

- Acoustic signal processing of the dual engine design offers superb signal clarity
- Dent-resistant hardened grille
- XLR connection with black finish
- Ships with protective zipper case, mic clip and brass stand adapter

NXN8C	Cardioid dynamic vocal microphone for professional performance	List-\$399.00	\$299.00
NXN8S	Supercardioid dynamic vocal microphone for professional performance	List-\$399.00	\$299.00



BETA57A



BETA58A



BETA87A

Great Sound and Built to Last

The Shure Beta 57A dynamic mic maintains a true supercardioid pattern throughout its frequency range. This insures high gain-before-feedback, maximum isolation from other sound sources, and minimum off-axis tone coloration. The Beta 58A dynamic mic offers warm sound with a smooth presence rise and extended top end. The Beta 87A supercardioid electret condenser mic gives you a smooth frequency response and high SPL capability with controlled low-frequency roll-off.

- BETA57A:**
- Tailored frequency response (50 Hz - 16 kHz) for studio quality sound
 - Hardened steel mesh grille facilitates use of proximity effect and resists wear
 - Neodymium magnet for high signal-to-noise ratio output

- BETA58A:**
- Extended top end
 - Smooth presence rise
 - Superior shock isolation

BETA57A	List-\$199.00	\$149.00
BETA58A	List-\$219.00	\$169.00
BETA87A	List-\$329.00	\$259.00

- BETA87A:**
- Smooth frequency response with gradual presence rise
 - Electronic low-frequency roll-off compensates for proximity effect
 - Wide dynamic range (117 dB) and low distortion

▶ See the video at bswusa.com/BETA57A

Accessories:

A58WSGRA	Windscreen - Gray	\$8.00
A58WSBK	Windscreen - Black	\$8.00



SM58LC



More online! Scan for full specs.

Ultimate Vocal Mic

This popular Shure dynamic mic is world-famous for bullet-proof durability and quality reproduction. You'd be hard-pressed to find a stage in the world without an SM58.

- Cardioid pick-up pattern
- Distinctive vocal presence peak
- Integral windscreen
- Includes stand clamp and pouch

▶ See the video at bswusa.com/SM58LC

SM58LC	SM-58 Mic	List-\$129.00	\$99.00
SM58S	SM-58 Mic with Switch	List-\$135.00	\$104.00
SM57LC	Classic Instrument Mic	List-\$129.00	\$99.00

Accessories:

A55M	Shockmount	\$24.95
A58WSGRA	Windscreen - Gray	\$8.00
A58WSBK	Windscreen - Black	\$8.00
RK143G	Replacement grill	\$10.00



KSM8-B

Specially Designed for Clear, Natural Sound

The Shure KSM8 dynamic cardioid handheld microphone features two ultra-thin diaphragms and reverse airflow technology for superior vocal reproduction with virtually no proximity effect. Its focused cardioid polar pattern rejects unwanted sounds. It's available in classic black and nickel finishes. Two ultra-thin diaphragms and reverse airflow technology

- Exceptional control of proximity effect
- Accurate frequency response for warm, natural sound
- Flat, broad off-axis attenuation for excellent vocal clarity
- Advanced pneumatic shock mount design rejects handling noise

KSM8-B	Black finish	\$399.00
KSM8-N	Nickel finish	\$399.00

BSW Has a Mic for Every Voice

BUY IN BULK AND SAVE!



More online! Scan for full specs.



THREEPACK835

\$249.95



Handy Handheld Mic 3-Packs

Sennheiser's E835 handheld microphone needs no introduction. One of the industry's most popular dynamic mics thanks to its even tonal response clarity and projection, it's now available in a money-saving three-pack.

THREEPACK835 3-pack of e835 mics



CAD Mic 3-Pack

Three-packs of CAD Audio's CADLive D32 supercardioid dynamic mic one of the best deals around. The CADLive D32 offers superior gain before feedback and a silent on/off switch.

D32X3 3-pack of CADLive D32 mics **\$59.00**



Samson Mic 3-Pack

Three-packs of Samson's R21 dynamic cardioid mic is one of the best deals around. The R21 boasts a built-in dual-stage windscreen, anti-dent ring and heavy-gauge mesh for enhanced protection.

R21 3-pack of R21 mics **\$49.99**



KMS105NI



KMS105MT

Handheld Condenser Mics From Neumann – Great Bang for your Bucks

KMS104:

- Cardioid condenser mic offers low self-noise and smooth frequency response
- Transparent voice reproduction; easily handles extreme sound pressure levels

KMS105:

- Supercardioid polar pattern, low self noise and uncolored off-axis pickup
- Unique 4-layer acoustic filter minimizes popping and wind noise

KMS104MT	Cardioid, Black	\$729.00
KMS104NI	Cardioid, Nickel	\$729.00
KMS105MT	Hypercardioid, Black	\$729.00
KMS105NI	Hypercardioid, Nickel	\$729.00



Excellent, rugged stage mic!

Solid Stage Vocal Mic

Sennheiser's E835 dynamic cardioid vocal stage mic is a great general performer. A gentle presence boost evens tonal response and enhances clarity and projection, and minimal proximity effect provides consistently clear bass and superb performance even with inconsistent distance. Comes with bag and clip. The E835S adds an On/Off switch for PA or stage use. The E845 offers a super cardioid pattern and on/off switch.

E835	Without on/off Switch	\$99.95
E835S	With on/off Switch	\$99.95
E845	Supercardioid Pattern	\$99.95



Built for Life on the Road

A workhorse with the soul of a thoroughbred, the Sennheiser e935 cardioid vocal microphone performs under pressure while cutting through the mix with its high output. Perfect for the gigging musician or sound engineer, the e935 gets the job done in style day in and day out.

E935	\$199.95
E945	\$199.95



Shotgun Microphones and Accessories

BSW
CUSTOMER
FAVORITE



Shotguns for Every Budget

RØDE's NTG series of shotgun condenser microphones deliver premium audio recording in a wide range of applications. Offering broadcast-grade sound quality in even the most challenging environments, the microphones boast low noise circuitry, low handling noise and rugged, roadworthy metal construction. Call, or visit BSWUSA.com to learn more.

NTG1	Short shotgun	List—\$349.00	\$249.00
NTG2	With internal power	List—\$369.00	\$269.00
NTG3	Nickel finish	List—\$899.00	\$699.00
NTG3-B	Black finish	List—\$899.00	\$699.00
NTG8	Top of the line	List—\$1,299.00	\$999.00
NTG4	Shotgun mic	List—\$499.00	\$369.00
NTG4-PLUS	With digital switches	List—\$599.00	\$399.00

10-Year
Warranty

RØDE

Great Mics for Video

RØDE's popular VideoMic-Pro shotgun mic is designed for use with digital video cameras. Conveniently 9V-battery powered, its built-in shockmount significantly reduces handling noise. It also features a stereo minijack audio output and standard hot-shoe fitting. Windscreen and hot-shoe mount included.

VIDEOMIC-PRO-R	Built-in shockmount	\$229.00
VIDEOMIC-R	Studio quality	\$149.00
VIDEOMIC-ME	Compact	\$59.00



RØDE



More online!
Scan for full specs.

Give Your Voice a Competitive Edge

RADIO LEGEND AND LONG-TIME BSW CUSTOMER JOE CIPRIANO'S FAVORITE MIC!



BSW
CUSTOMER
FAVORITE



Industry-Favorite Shotgun Mic

Sennheiser's MKH416 short shotgun microphone is a great all-around performer for film, radio, television and outdoors use due to its directional sensitivity, high consonant articulation and excellent feedback rejection. It is also one most valued mics in the world for voice-over applications. Call, email or check out our website for more details on this fantastic mic.

MKH416P48U3 **\$999.00**

- RF-bias capsule, pressure-gradient receiver with short interference tube
- High directivity, low self noise
- Superb consonant articulation and feedback rejection
- Hypercardioid at low and medium frequency (above 2 kHz approaches lobar pattern)
- Handles difficult exterior filming and reporting conditions with ease
- 40 Hz - 20 kHz frequency response
- Handles up to 130 dB SPL
- Rugged construction with black matte finish
- Windscreen included

SENNHEISER



Great Short Shotgun Mic for Camcorders

The Sennheiser MKE 600 camcorder microphone can handle even the toughest video sound challenges. Its high level of directivity focuses in on desired sounds while filtering out distracting noise. Wind noise is reduced using the included foam windshield, while a switchable low-cut filter lets you minimize wind and handling noise as well. It can be phantom-powered or operated on an AA battery for about 150 hours.

- Exceptional directivity
- Maximum attenuation of background noise
- Low-cut filter for minimizing wind noise
- 40 Hz - 20 kHz frequency response
- Phantom (P48) or battery powered
- Durable all-metal housing

MKE-600 **\$329.95**

SENNHEISER



VP82

I Call Shotgun!

Professional shotgun condenser microphones deliver superior off-axis rejection for focus and flexibility in a wide variety of on-site locations.

VP82	Short, integrated	\$329.00
VP83F	Camera mounted, flash recording	\$299.00
VP88	M-S stereo	\$799.00
VP89L	Long condenser shotgun	\$1,154.00
VP89S	Short condenser shotgun	\$765.00
VP89M	Medium condenser shotgun	\$996.00

SHURE
REAL SOUND



WSVM



DEADCAT

Reliable Shotgun Mic Windscreens

The Windtech SG2 fits many medium-length shotgun models. Windtech's Big-Gun fits most short shotguns. RØDE's WSVM windscreen and DeadCat wind muff fit the RØDE NTG1, NTG2 and VideoMic.

SG2	Medium shotgun windscreen	\$42.99
BG-1	Short shotgun windscreen	\$39.99
WSVM	NTG1, NTG2, VideoMic windscreen	\$11.99
DEADCAT	NTG1, NTG2, VideoMic wind muff	\$39.00

With its huge selection and great prices, BSW is the go-to place for professional voice-over gear.

Call BSW to Help Configure Your Microflex System



Ultimate Digital Wireless Conference System

Shure's Microflex® Complete Wireless empowers meeting participants to share ideas and make decisions anywhere. Advanced Shure wireless technology delivers reliable performance in any environment without complicated setup or cable limitations. Handsfree microphone activation provides touchless convenience for free-flowing conversations (or choose manual or remote control for formal meetings). Call, email, or visit BSWUSA.com for full specs.

- Automatic Frequency Coordination for quick and easy setup
- Uses global 2.4/5 GHz spectrum including DFS channels to maximize available spectrum
- Built-in RF spectrum manager constantly monitors available channel quality
- Automatic Interference Detection and Avoidance resolves potential transmission problems in congested RF environments
- High spectral efficiency allows up to 125 units on one WLAN channel
- Proprietary Shure audio codec for natural, intelligible sound quality
- Automatic Gain Control for consistent speech levels for each talker
- Robust AES-128 audio encryption for enhanced privacy

MXW8	Desktop base transceiver	List—\$910.00	\$650.00
MXW8W	Desktop base transceiver	List—\$910.00	\$650.00
MXW6C	Boundary transceiver, cardioid	List—\$990.00	\$707.00
MXW6/O=Z10	Boundary transceiver, omni	List—\$990.00	\$707.00
MXW6WC	Boundary transceiver, cardioid, white	List—\$990.00	\$707.00
MXW6WO	Boundary transceiver, omni, white	List—\$990.00	\$707.00
MXW6XC	Microphone, boundary, cardioid	List—\$838.00	\$670.00
MXW6XO	Microphone, boundary, omni	List—\$838.00	\$670.00
MXW6XWC=Z10	Microphone, boundary, cardioid, white	List—\$838.00	\$670.00
MXW6XWOO	Microphone, boundary, omni, white	List—\$838.00	\$670.00
MXW10	Bodypack transmitter with integrated omnidirectional microphone and 4-pin mini connector	List—\$874.00	\$624.00
MXWAN14	4-ch network interface	List—\$1,828.00	\$1,306.00
MXWAN18	8-ch network interface	List—\$1,954.00	\$1,396.00
MXWAPT2	2-ch access point transceiver	List—\$2,044.00	\$1,460.00
MXWAPT4	4-ch access point transceiver	List—\$4,124.00	\$2,946.00
MXWAPT8	8-ch access point transceiver	List—\$5,334.00	\$3,810.00
MXWAPXD2	Access Point, charger, DSP, 2-ch	List—\$1,624.00	\$1,299.00
MXWNC52	2-ch networked charging station	List—\$910.00	\$650.00
MXWNC54	4-ch networked charging station	List—\$2,158.00	\$1,541.00
MXWNC58	8-ch networked charging station	List—\$2,780.00	\$1,986.00

Cut The Cord. BSW has the Wireless System For You!

Advanced, Scalable Digital Wireless

Shure's premier Axient Digital Wireless System offers exceptional signal stability and audio clarity, along with flexible hardware options, advanced connectivity to handle today's wireless challenges as well as possible changes in the future. Call, email, or visit BSWUSA.com for full specs.

AD2-B58	List—\$1,376.00	\$1,101.00
AD2-B87A	List—\$1,516.00	\$1,213.00
AD2-B87C	List—\$1,516.00	\$1,213.00
AD2-K8B	List—\$1,808.00	\$1,446.00
AD2-K8N	List—\$1,808.00	\$1,446.00
AD2-K9B	List—\$2,294.00	\$1,835.00
AD2-K9N	List—\$2,294.00	\$1,835.00
AD2-K9HSB	List—\$2,294.00	\$1,835.00
AD2-K9HSN	List—\$2,294.00	\$1,835.00
AD2-SM58	List—\$1,238.00	\$990.00
AD2-VP68	List—\$1,426.00	\$1,141.00
AD4DUS-A	List—\$4,473.00	\$3,578.00
AD4QUS-A	List—\$8,946.00	\$7,157.00
AD4Q-A	List—\$8,501.00	\$6,801.00
AD4D-A	List—\$4,251.00	\$3,401.00
ADX5DUS-A	List—\$3,125.00	\$2,500.00
SBRC-US	List—\$835.00	\$668.00
AD610	List—\$635.00	\$508.00



Customer-Favorite Shure ULX-D Digital Wireless Series

Shure ULX-D Digital Wireless offers uncompromising 24-bit audio clarity and extremely efficient RF performance with single, dual, and quad channel receivers for any size professional sound reinforcement application. Scalable, intelligent hardware delivers the best performing digital wireless available, with a wide selection of trusted Shure microphones to choose from. Call, email, or visit BSWUSA.com for full specs.

- 24-bit/48 kHz digital audio delivers clear and accurate sound
- 20 Hz–20 kHz frequency range with flat response
- Greater than 120 dB dynamic range through the analog outputs
- 130 dB dynamic range (typical) using Dante and AES67 digital networked audio
- 60 dB of adjustable system gain accessible from receiver front panel
- Optimized for any input source, no transmitter gain adjustment needed
- Up to 64 MHz overall tuning range (region dependent)
- Single (half-rack), Dual, and Quad (full-rack) receivers
- Bodypack frequency diversity ensures uninterrupted audio

ULXD8	List—\$774.00	\$553.00
ULXD60	List—\$852.00	\$609.00
ULXD6C	List—\$852.00	\$609.00
ULXD4Q	List—\$9,034.00	\$6,453.00
ULXD4	List—\$1,578.00	\$1,127.00
ULXD2-SM87	List—\$1,136.00	\$811.00
ULXD2-SM86	List—\$1,000.00	\$714.00
ULXD2-SM58	List—\$852.00	\$852.00
ULXD2-K8N	List—\$1,636.00	\$1,169.00
ULXD2-K8B	List—\$1,636.00	\$1,169.00
ULXD2-B87C	List—\$1,136.00	\$811.00
ULXD2-B87A	List—\$1,136.00	\$811.00
ULXD2-B58	List—\$1,000.00	\$714.00
ULXD1	List—\$794.00	\$567.00



More online! Scan for full specs.

There's a mic for every voice! Let us help you choose the right one. 800.426.8434

BSW: Your Destination for Wide Open Wireless

Wireless Priced Right from Audio-Technica and BSW



Shure's Transparent, Rock-Solid SLX-D Wireless System

Shure's SLX-D digital wireless system delivers transparent, 24-bit digital audio and rock solid RF performance with easy setup and a wealth of versatile system configurations. Choose from single half-rack and dual full-rack receiver options, handheld and bodypack transmitters and a wide selection of vocal, lavalier, headset and instrument microphone system configurations. **Models listed below operate in the G58 frequency band (470-514 MHz).** For full specs, call a BSW GearHead, or visit BSWUSA.com.

SLXD1	Wireless bodypack Transmitter	List—\$287.00	\$229.00
SLXD24-B58	Wireless handheld system with Beta 58A capsule	List—\$949.00	\$749.00
SLXD24-B87A	Wireless handheld system with Beta 87A capsule	List—\$1,059.00	\$839.00
SLXD24D-B58	Dual wireless handheld system with Beta 58A capsules	List—\$1,849.00	\$1,479.00
SLXD24D-SM58	Dual wireless handheld system with SM58 capsules	List—\$899.00	\$699.00
SLXD24D-N8CB	Dual HH sys w/N8CB mic	List—\$2,224.00	\$1,779.00
SLXD24D-N8SB	Dual HH sys w/N8SB mic	List—\$2,224.00	\$1,779.00
SLXD24-SM58	Wireless handheld system with SM58 capsule	List—\$899.00	\$699.00
SLXD2-B58	Wireless handheld transmitter with Beta 58A capsule	List—\$412.00	\$329.00
SLXD2-B87A	Wireless handheld transmitter with Beta 87A capsule	List—\$524.00	\$419.00
SLXD2-K8B	Wireless handheld transmitter with KSM8 capsule	List—\$794.00	\$635.00
SLXD2-SM58	Wireless handheld transmitter with SM58 capsule	List—\$349.00	\$279.00
SLXD4D	Dual channel digital wireless receiver	List—\$562.00	\$449.00
SLXD4	Single channel digital wireless receiver	List—\$1,061.00	\$849.00
SLXD2-N8S-B	Wireless handheld transmitter with Nexadyne 8/S capsule	List—\$599.00	\$479.00

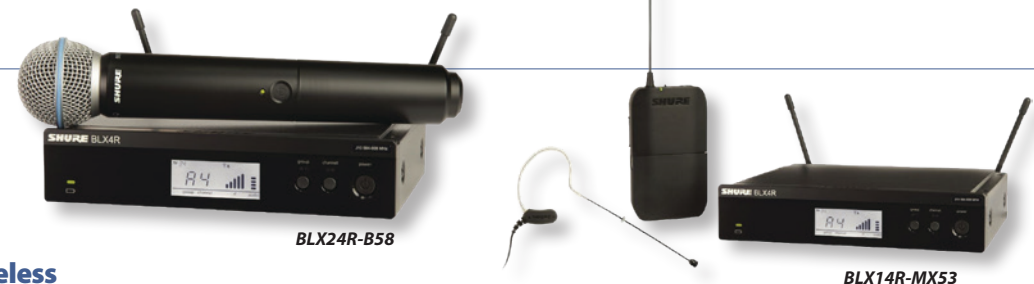

Flexible, Entry-Level BLX Wireless

Shure BLX is an ideal entry-level wireless microphone system for small venues, offering professional quality sound with simple setup and an intuitive interface. There are multiple configurations to choose from, including lavalier mic systems, wireless handheld mic systems, headset systems, instrument systems, and rackmount systems. Configurations are available in H9 band (512-542 MHz) and H10 band (542-572 MHz) frequency ranges.

BLX14R-MX53	Single Channel Earsset Wireless Microphone System with 1/2 Rack	List—\$729.00	\$599.00
BLX24R-SM58	Single Channel Wireless Mic System with SM58 Transmitter with 1/2 Rack	List—\$529.00	\$429.00
BLX288-PG58	Dual Channel Wireless System with PG58 (2) Transmitters	List—\$763.00	\$599.00
BLX288-SM58	Dual SM58 Vocal Wireless System	List—\$882.00	\$699.00
BLX14R-B98	Single Channel Instrument Wireless Microphone System with 1/2 Rack	List—\$679.00	\$539.00
BLX14R-W93	Single Channel Wireless LAV System with 1/2 Rack	List—\$569.00	\$449.00
BLX24-B58	Single Channel Wireless Mic System with BETA58 Transmitter	List—\$519.00	\$409.00
BLX24R-B58	Single Channel Wireless Mic System with BETA58 Mic and 1/2 Rack	List—\$599.00	\$489.00

Plug-and-Play, Hassle-Free Wireless System

Audio-Technica's System 20 PRO is a self-managing, plug-and-play 2.4 GHz system that's scalable to 20 channels and delivers consistently high-quality audio regardless of where you set it up. Designed for hassle-free deployment, the system overcomes many challenges of conventional wireless microphones, such as frequency coordination, complex intermodulation calculations, and remote antenna cabling.

- Digital 24-bit/48 kHz wireless operation for ultimate sound quality and dependable performance
- Plug-and-play operation in the 2.4 GHz range – free from TV interference
- Switchable between Standard mode (10 channels) and HD mode (20 channels) to minimize latency or maximize channel count, respectively
- Receiver units can be docked in the chassis or mounted remotely (up to 328 feet away) via Ethernet cable for added versatility
- Up to five chassis can be linked and used simultaneously

ATW-1421	2Ch BP 2.4 GHz Wireless	\$959.00
ATW-1422	2Ch HH 2.4 GHz Wireless	\$999.00
ATW-1423	2Ch Combo 2.4 GHz Wireless	\$979.00
ATW-R1440	Receiver 2.4 GHz	\$599.00
ATW-T1401	BP Transmitter 2.4 GHz	\$249.00
ATW-T1402	HH Transmitter 2.4 GHz	\$269.00
ATW-T1406	Boundary TX 2.4 GHz	\$399.00
ATW-T1407	Desk Stand TX 2.4 GHz	\$349.00
ATW-RC13	Digital Wireless	\$249.00

Powerful, Flexible Fourth-Generation 3000 Series

Audio-Technica's fourth-generation 3000 Series wireless systems give you the power and flexibility to operate within the congested UHF spectrum. 3000 Series systems have an operating range of 300 feet and are available in two frequency bands – DE2 (470–530 MHz) and EE1 (530–590 MHz). Available system configurations feature an ATW-R3210 receiver or an ATW-R3210N network-enabled receiver along with an ATW-T3201 bodypack or ATW-T3202 handheld transmitter. Visit BSWUSA.com for full specs.

- Frequency-agile true diversity UHF wireless systems
- 60MHz UHF tuning bandwidth for clean, uninterrupted signal
- 300-foot operating range for ample elbow room
- Frequency scan and IR sync functionality for ease of setup
- Transmitter multifunction button for fast switching to backup frequency
- OLED screens on receivers for optimal readout of key settings and alerts
- Balanced and unbalanced audio output jacks



ATW-3211-892XDE2	Headworn mic system (470–530 MHz)	\$839.00	ATW-3211N893XTHDE2	Network beige headworn sys (470–530 MHz)	\$879.00
ATW-3211-892XTHDE2	Headworn (beige) mic system (470–530 MHz)	\$839.00	ATW-3211N894XDE2	Network headworn mic system (470–530 MHz)	\$999.00
ATW-3211-893XDE2	Headworn mic system (470–530 MHz)	\$779.00	ATW-3211N894XTHDE2	Network beige headworn sys (470–530 MHz)	\$999.00
ATW-3211-893XTHDE2	Headworn (beige) mic system (470–530 MHz)	\$779.00	ATW-3211NDE2	Network receiver, bodypack (470–530 MHz)	\$649.00
ATW-3211-894XDE2	Headworn mic system (470–530 MHz)	\$899.00	ATW-3212-C510DE2	Handheld mic system (470–530 MHz)	\$599.00
ATW-3211-894XTHDE2	Headworn (beige) mic system (470–530 MHz)	\$899.00	ATW-3212-C710DE2	Handheld mic system (470–530 MHz)	\$699.00
ATW-3211DE2	Receiver, bodypack transmitter (470–530 MHz)	\$549.00	ATW-3212DE2	Handheld mic system (470–530 MHz)	\$509.00
ATW-3211N831DE2	Network lavalier mic system (470–530 MHz)	\$749.00	ATW-3212NC510DE2	Network handheld mic system (470–530 MHz)	\$699.00
ATW-3211N892XDE2	Network headworn mic system (470–530 MHz)	\$939.00	ATW-3212NC710DE2	Network handheld mic system (470–530 MHz)	\$799.00
ATW-3211N892XTHDE2	Network beige headworn sys (470–530 MHz)	\$939.00	ATW-3212NDE2	Network handheld mic system (470–530 MHz)	\$609.00
ATW-3211N893XDE2	Network headworn mic system (470–530 MHz)	\$879.00	ATW-3255DF2	In-ear monitor system	\$849.00



Compact Sennheiser Wireless

Better Gear BETTER SOUND

If you have something to say, you want people to hear it. And while crafting your message is vitally important for attracting listeners, so is the craftsmanship of the equipment you use. Second-rate ideas don't go very far. Neither do first-rate ones using second-rate gear.

At BSW, we make sure we have the finest gear available, crafted to handle the demands of a wide range of broadcasting applications. We also make sure we know the equipment we sell, so we can put the right tools in your hands to make your voice travel farther.

BSWUSA.COM



BSW



youtube.com/bswusavideo



facebook.com/bswusa



@bswusa on Twitter



bswusa.wordpress.com



BSWUSA



Wireless Handheld Performance Set

This XS WIRELESS 1 VOCAL SET is an easy to use wireless system ideal for live sound featuring Sennheiser evolution mic capsules, e825 (dynamic, cardioid) or e835 (superior dynamic, cardioid).

- EM-XSW 1 receiver, handheld transmitter (SKM 825-XSW or SKM 835-XSW) and more
- Available in multiple frequency ranges (call or visit BSWUSA.com for more options)

XSW-1-835-A 548-572 MHz **\$349.00**



Wireless Headworn Presentation Set

The XS WIRELESS 1 HEADMIC SET is an easy to use all-in-one wireless system for singers and presenters, and is excellent for live sound that involves dancing and singing all at the same time.

- EM-XSW 1 stationary receiver, ME 3-1 headset mic, SK-XSW bodypack transmitter and more
- Available in multiple frequency ranges (call or visit BSWUSA.com for more options)

XSW-1-ME3-A 548-572 MHz **\$399.00**



Wireless Handheld Vocal Sets

These XS Wireless 2 vocal sets are perfect for live vocals, stage performance and presentations. They feature evolution mic capsules e835 or e865 and operate in the 548-572 MHz band.

- EM-XSW 2 receiver, SKM 835-XSW or SKM 865-XSW handheld transmitters and more
- Available in multiple frequency ranges (call or visit BSWUSA.com for more options)

XSW2-835-A **\$449.00**
XSW2-865-A **\$499.00**



Wireless Handheld Vocal Set

This XS WIRELESS 1 VOCAL SET is an easy to use all-in-one wireless system specially designed for speech featuring Sennheiser evolution mic capsules, e825 (dynamic, cardioid) or e835 (superior dynamic, cardioid).

- EM-XSW 1 receiver, handheld transmitter (SKM 825-XSW or SKM 835-XSW) and more
- Available in multiple frequency ranges (call or visit BSWUSA.com for more options)

XSW-1-825-A 548-572 MHz **\$299.00**



Wireless Lavalier Presentation Set

This XS WIRELESS 2 LAVALIER MIC SET is an easy to use all-in-one wireless system for presenters and moderators, featuring a lightweight bodypack transmitter and an unobtrusive clip-on microphone.

- EM-XSW 2 stationary receiver, ME 2-2 lavalier mic, SK-XSW bodypack transmitter and more
- Available in multiple frequency ranges (call or visit BSWUSA.com for more options)

XSW2-ME2-A 548-572 MHz **\$479.00**



Wireless Headworn Performance Set

This XS WIRELESS 2 HEADMIC SET is an easy to use all-in-one wireless system for singers and performers, ideal for live performances involving dancing and singing all at the same time.

- EM-XSW 2 receiver, ME3-II headworn mic, SK-XSW bodypack transmitter and more
- Available in multiple frequency ranges (call or visit BSWUSA.com for more options)

XSW2-ME3-A 548-572 MHz **\$499.00**



Wireless Lavalier Presentation Set

This XS WIRELESS 1 LAVALIER MIC SET is an intuitive all-in-one wireless system for presenters and moderators, with the tools you need to deliver a powerful and inspiring presentation.

- EM-XSW 1 stationary receiver, ME 2-2 lavalier mic, SK-XSW bodypack transmitter and more
- Available in multiple frequency ranges (call or visit BSWUSA.com for more options)

XSW-1-ME2-A 548-572 MHz **\$379.00**



Wireless In-Ear Monitor Set

This XS Wireless IEM set delivers the whole potential of in-ear monitoring with an elegant, easy-to-use interface with no tech expertise needed to master.

- XSW IEM EK stereo receiver, XSW IEM SR stereo transmitter, IE 4 In-ear headphones and more
- Available in multiple frequency ranges (call or visit BSWUSA.com for more options)

XSW-IEM-SET-A 548-572 MHz **\$599.00**



More online!
Scan for full specs.



Sennheiser's Intelligent Wireless

The Future of Wireless is Here



NEW

EW8355-SET-Q1



NEW

EWDM2-SET-Q1



NEW

EWDM28355-SET-Q1



NEW

EWDM3-SET-Q1

UHF Wireless System Offers Highest Dynamic Range, Lowest Latency

Sennheiser's Evolution Wireless Digital offers the highest dynamic range and lowest latency of any wireless system currently available, with advanced features that simplify your setup and guarantee an ultra-reliable connection. The Sennheiser Smart Assist app lets you maximize efficiency and take control of your system, automatically coordinating frequencies with ease. Call, email or visit BSWUSA.com for full specs.

- UHF digital transmission greatly enhances range, reliability and scalability
- Highest dynamic range (134 dB) and ultra-wide tuning bandwidth (56 MHz)
- Equidistant tuning grid simplifies frequency coordination
- Smart Assist app for iOS and Android provides easy control and setup
- EW-D EM digital rack receiver included with sets
- EW-D SKM-S handheld transmitter compatible with many Sennheiser/Neumann capsules
- EW-D SK bodypack transmitter
- Me-2, ME-3 and ME-4 lavalier and headworn mics
- Handy rechargeable battery pack available

EW8355-SET-Q1	Handheld set, e835 cardioid mic (470-526 MHz)	List—\$849.00	\$699.00
EWDM2-SET-Q1	Lavalier set, ME-2 omni mic (470-526 MHz)	List—\$849.00	\$699.00
EWDM3-SET-Q1	Headworn set, ME-3 cardioid mic (470-526 MHz)	List—\$899.00	\$749.00
EWDM4-SET-Q1	Lavalier set, ME-4 cardioid mic (470-526 MHz)	List—\$849.00	\$699.00
EWDC1-SET-Q1	Instrument set, CI 1 cable (470-526 MHz)	List—\$749.00	\$629.00
EWDSKBASE-SET-Q1	Bodypack transmitter set (470-526 MHz)	List—\$699.00	\$599.00
EWDSKMSBASE-SET-Q1	Handheld transmitter set, no mic (470-526 MHz)	List—\$699.00	\$599.00
EWDM28355-SET-Q1	All-in-one combo set (470-526 MHz)	List—\$1,250.00	\$999.00
EWDSK-Q1	Bodypack transmitter (470-526 MHz)	List—\$349.00	\$299.95
EWDSKMS-Q1	Handheld transmitter, no capsule (470-526 MHz)	List—\$349.00	\$299.95
EWD-CHARG-SET	Charging set for bodypack/handheld transmitters	List—\$179.00	\$149.95
BA70	Rechargeable battery pack	List—\$59.00	\$49.95
L70-USB	USB charger for BA70	List—\$75.00	\$59.95



More online!
Scan for full specs.



Revolutionary Bidirectional Wireless System

Featuring up to 64 channels (32 in/ 32 out) in a single unit, Sennheiser's Spectera is the world's first wideband, bidirectional digital wireless ecosystem. Spectera's 11 Audio Link modes give you unprecedented control of latency, audio quality and more for each link, while its bidirectional bodypack transmitters manage both in-ear monitor and mic/line signals simultaneously.

Sennheiser's wireless multichannel audio technology makes Spectera vastly more resistant to dropouts and RF fading than narrowband systems. Spectera also features built-in redundancy where it matters most: redundant power supplies, redundant Dante and optional redundant MADI audio I/O and more.

- Bidirectional wireless ecosystem; data and audio control in a single RF carrier for all components
- Bidirectional SEK bodypack manages both IEM and mic/line signals simultaneously
- Transceiving antennas manage IEM signals, mic/line signals, and data simultaneously
- Continuous bidirectional communication for full remote control and monitoring of SEK bodypack links, IEM volume, audio level and settings, RF health, battery status, and more
- 1 RU base station provides up to 64 channels (32 in / 32 out) and allows for up to two independent wideband RF carriers in UHF or 1G4 (6 or 8 MHz)

SPECTERA-BASE-STATION	List—\$11,749.00	\$9,999.00
SPECTERA-SEK-1G4	List—\$2,349.00	\$1,999.00
SPECTERA-SEK-UHF	List—\$2,349.00	\$1,999.00
SPECTERA-DAD-UHF	List—\$1,899.00	\$1,599.00
SPECTERA-DAD-1G4	List—\$1,899.00	\$1,599.00
SPECTERA-MADI-CARD-BNC	List—\$179.00	\$149.00
SPECTERA-MADI-CARD-OM	List—\$179.00	\$149.00
SPECTERA-SEK-ANTENNA-UHF	List—\$59.00	\$49.95
SPECTERA-SEK-ANTENNA-1G4	List—\$59.00	\$49.95
SPECTERA-SEK-BELT-CLIP	List—\$11.95	\$9.95



NEW



SPECTERA-SEK-1G4

NEW



NEW



SPECTERA-BASE-STATION

BSW

ADVANTAGE CLUB

EXCLUSIVE DISCOUNTS

GET THE VIP TREATMENT

MORE WAYS TO SAVE & PAY

BECOME A **MEMBER**

Apply on BSWUSA.com under accounts, email sales@bswusa.com or Call 1-800-426-8434.



BP28L BP28



/ Broadcast and Production Microphones

Capture Every Detail

Audio-Technica offers a wide selection of shotgun, boundary, and X/Y stereo microphones — plus a state-of-the-art immersive audio mic — tailored for broadcast and production applications. Whether deployed to capture full stereo sound of fast-moving action, set atop a camera to sync with video, or placed in a common area to pick

up conversation or ambient sound, our versatile, rugged broadcast mics can be grouped to ensure complete capture of any event. The official Broadcast Partner of MotoAmerica, Audio-Technica is the trusted source for detailed, full-spectrum broadcast audio.



Call BSW for your best price on Audio-Technica 1-800-426-8434

This Buy 2, Get 1 Free deal makes me feel 10 inches taller!

800.426.8434



BPHS1-342



Joey Boothe, GearHead, JoeyB@bswusa.com

Rugged, Affordable Headset

Perfect for sports broadcasting, announcing and interviews, this rugged Audio-Technica headset is the full meal deal.

- Cardioid dynamic microphone rejects off-axis sounds
- Boom-mounted microphone can be positioned on the left or right side
- Headphone is closed-back to seal out background noise.
- Detachable cable terminates in 3-pin XLRM for microphone and 1/4" headphone
- Frequency Response 20-20,000 Hz (Headphone) 40-20,000 Hz (Microphone)

BPHS1		\$219.00
BPHS1-342	Buy 2 get 1 FREE	\$438.00
Accessories:		
AT8162	Windscreens 3 pack	\$29.00

▶ See the video at bswusa.com/BPHS1



Broadcasters rely on Audio-Technica headsets for dependable remotes.



More online! Scan for full specs.

BSW
CUSTOMER FAVORITE



High-Fidelity Broadcast Headset

Specially designed for news and sports broadcasting, the rugged Audio-Technica BPHS2 stereo headset offers highly intelligible and commanding vocal reproduction, along with a comfortable fit and excellent sound isolation.

- Low-profile, closed-back design provides excellent isolation and fit
- Proprietary 45 mm large-aperture drivers
- Hypercardioid dynamic microphone with frequency response tailored for commanding, broadcast-ready vocal reproduction
- Low-impedance design for high output level from any headphone output
- Boom-mounted microphone can be positioned on the left or right side

BPHS2A		\$349.00
BPHS2S	Single-ear version	\$329.00
BPHS2C	Condenser mic version	\$399.00

BSW
CUSTOMER FAVORITE



Headsets for Noisy Environments



BSW
CUSTOMER
FAVORITE

Ideal Broadcast Headset

Sennheiser's HMD 300 XK31 offers crystal clear sound, ActiveGard hearing protection, and a wide frequency response. It comes with a copper XLR cable that reduces structure-borne noise.

- Dual-sided earcup design ideal for noise isolation/immersion
- Dynamic super-cardioid mic for clarity in noisy environments
- Switchable ActiveGard technology keeps noise peaks at bay

HMD300-XK31 List \$399.00 **\$349.00**



HMD26

BSW
CUSTOMER
FAVORITE

Great Broadcast Headsets

Sennheiser's HMD 26 features extra soft ear cushions and headband paddings for outstanding wearing comfort. Its closed, supra-aural headphones deliver high maximum SPL and provide good passive noise attenuation. The HMD 26-boasts a pre-polarized condenser microphone for crystal clear audio transmission. It's available with or without a terminated XLR cable.

The HMD 27 sports a dynamic microphone and a closed, circumaural earcup design. Its headband is specially constructed to deliver exceptional wearing comfort over long working hours. It comes with a terminated XLR cable.

- Accurate and linear sound reproduction for professional Radio and TV applications
- ActiveGard for protected hearing
- Swiveling ear cap for single sided listening

HMD26 List \$599.00 **\$499.00**
HMD26-XLR-S List \$718.00 **\$599.00**
HMD27-XLR-S List \$718.95 **\$599.95**



HMD27-XLR



BRH440M-XLR-S

BRH50M

Dedicated Shure Broadcast Headsets

Specially designed for broadcast and media production applications, these Shure headsets have the features today's broadcasters demand. Each provides exceptional audio quality, comfort, and durability to meet the exacting standards of field production professionals.

BRH440M-XLR-S List \$365.95 **\$249.00**
BRH441M-XLR List \$340.95 **\$229.00**
BRH50M List \$499.00 **\$419.00**



HME46

Pro Broadcast Headsets

The HME 46 broadcast headset delivers the extreme comfort, communication audio quality, and reliability you need with an open-back design that keeps you connected to your environment. The stereo earphones provide precise audio reproduction from 16 - 20 kHz while the noise-canceling, pre-polarized condenser microphone offers extended speech intelligibility.

The HMD 46 broadcast headset excels at intercom applications and ensures reliable communication and all-day comfort. Its noise-canceling dynamic microphone enhances intelligibility, while stereo earphones reproduce clear audio from 16 Hz to 20 kHz.

- Noise-compensated condenser microphone for detailed sonic characteristics
- Patented two-piece automatic headband for easy adjustment
- Swiveling ear cap for single sided listening

HME46 List \$349.00 **\$299.00**
HMD46 List \$349.00 **\$299.00**
CABLE-II-X3K1-GOLD List \$119.00 **\$99.95**
CABLE-II-X3K1 List \$119.00 **\$99.95**
CABLE-II-X4F List \$119.00 **\$99.95**
CABLE-II-8 List \$99.00 **\$79.00**



HMD46



CABLE-II-X3K1-GOLD

Does this make my head look big? Be honest.

800.426.8434

John Lynch, GearHead
JohnL@bswusa.com

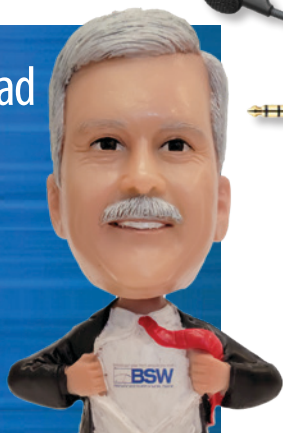

NEW



Portable Battery Powered Headphone Amp

The ZHA-4 splits a single stereo headphone output into four separate powered 1/8" headphone jacks, each with their own volume and mute control. Two AA batteries provide hours of portable power. For longer sessions, just connect the USB-C port to a portable battery or plug directly into the wall.

ZHA-4 **\$79.99**



High-Performance Battery-Powered Headphone Amp

Sound Device's compact HX-3 Headphone Distribution Amplifier quickly provides three high-performance stereo headphone feeds with individual level controls. It can produce very high headphone levels with minimal noise and distortion and is powered by inexpensive batteries (two-AA) or external 5-18 VDC.

HX-3 **\$595.00**



Flexible, Expandable Headphone Amp

The Rolls RA102 is a 10-channel professional headphone amplifier with a host of connections to handle any professional application. Its join function allows many RA102s to be linked together without any signal loss or impedance issues.

- 1U chassis to maximize your rack space
- Both balanced XLR and unbalanced RCA inputs
- Ten 1/4" TRS stereo and ten 1/8" TRS stereo outputs
- Suitable for a wide range of headphones

RA102 List \$289.00 **\$209.00**



HM-4

HM-400

HM-800

Hot Headphone Amps from Mackie

Mackie's HM-400 and HM-800 are 4- and 8-channel (respectively) rackmount headphone amps. The HM-4 is a compact, single-channel 4-way headphone amp

- L/R Main stereo inputs plus L/R stereo outputs (HM-400)
- 2 discrete main stereo inputs with separate level control plus stereo output (HM-800)
- 3 headphone outputs per channel for 12 total (HM-400)
- 2 headphone outputs per channel for 16 total (HM-800)

HM-4 **\$39.99**
HM-400 **\$199.99**
HM-800 **\$249.99**



ART Multi-Channel Headphone Amplifier

The ART HeadAmp4 four-channel stereo headphone amplifier offers 1/8" and 1/4" I/O as well as lower noise, lower distortion and more output in a stackable metal case. It lets you easily add additional headphone outputs to any mixer, computer audio interface, workstation, iPod, media player or laptop without creating any additional load on the existing headphone source.

Individual level controls for the four headphone outs and 1/4" and 1/8" connections give you great flexibility for connecting to virtually any source, including studio phones, in-ear monitors, custom earpieces (or all of the above).

HEADAMP4 4-channel headphone amplifier List \$109.99 **\$89.99**



RA62C

RA53B

HA43PRO

BSW
CUSTOMER
FAVORITE

Powerful, Reliable Headphone Amps

Rolls offers portable and rackmount solutions for large production rooms or your smaller home setup.

RA62C:

- Six headphone and six earphone outputs per channel with level controls
- Headphone and earphone outputs may be used simultaneously
- 1/4", RCA and XLR main inputs; 6 TRS stereo insert jacks
- CLIP LED for each channel

RA53B:

- Five 1/4" TRS headphone outputs with level controls
- 1/4" and 3.5mm outs can be used simultaneously for 10 total outputs
- XLR, 1/4" and RCA right and left inputs
- Inserts on three channels

HA43PRO:

- Stereo 1/4" and dual RCA inputs
- Slider volume controls
- 20 Hz-20 kHz frequency response

RA62C 6-channel List \$306.00 **\$239.00**
RA53B 5-channel List \$179.00 **\$139.00**
HA43PRO 4-channel List \$99.00 **\$69.00**



BSW
CUSTOMER
FAVORITE



Headphone Monitoring and Talkback Systems



HS-1-HDPN

BSW
CUSTOMER
FAVORITE



TS-1-TALENT

Audioarts TS-1 and HS-1 Headphone Stations

The Audioarts TS-1 and HS-1 are tough, compact units that utilize high-gain headphone amplifiers that multiply voltage and current to provide GREAT, LOUD sound to headphones of any impedance. TS-1 features 1/4" and mini stereo output jacks, two panel switches with internal LEDs, a power light, a level control and a LOGIC RJ45 that lets you to use the two front panel switches for TB, COUGH and other functions. Wiring is through cutouts in the bottom of the unit. HS-1 is a tiny

(2-3/4" by 3-3/4") headphone station designed for broadcast use. It can be used free-standing or optionally mounted under a counter.

HS-1-HDPN List-\$225.00*
TS-1-TALENT List-\$289.00*



*Prices too low to advertise. Call BSW for the lowest price 1-800-426-8434.



Add Headphone Out(s) to Your Console

The Arrakis ARC-HP is a compact stereo headphone amplifier that directly connects to any broadcast console.

- Provides additional headphone output for your console
- Daisy chain ARC-HPs for multiple headphone outputs
- Logic and Audio interface with Talkback and Cough buttons



ARC-HP List-\$195.00 **\$190.00**

Handy Portable Headphone Amp

JK Audio combines premium audio electronics in rugged belt pack designs. RemoteAmp works as an IFB earpiece or headphone amplifier. It accepts an XLR audio input from a mixer, distribution amplifier, telephone line hybrid or a handset interface.

- XLR line level input, 3.5 mm stereo input jack
- 3.5 mm earpiece jack, 1/4-inch headphone jack
- Compatible with party line intercoms
- More than 20 hours operation on one 9-volt battery
- Integrated speaker (RemoteAmp Three)



REMOTEAMP List-\$275.00 **\$259.00**

JK Audio



HP2



HP4



Hot Headphone Amps

PreSonus HP-series headphone amplifiers offer loud, clean, clear sound in a rugged design. The HP2 delivers these qualities in an easily affordable, portable, stereo device that can be powered by a 9V battery or the included DC power supplies. The HP4 features four discrete headphone outputs on the front panel each with its own volume control.

HP2 **\$129.99**
HP4 **\$149.99**

Multi-User Headphone System With Zoned Talkback

Henry Engineering's MultiPhones II system, consisting of a Master unit and up to 12 satellite Guest Pods interconnected with standard CAT5 cabling, offers independent stereo headphone listening facilities with Zoned Talkback for up to 12 users.

- **MultiPhones II:** Master unit distributes Program audio to all Guest Pods or MiniPods via three outputs, with each output working as an isolated Talkback zone
- **Guest PodII:** stereo headphone amplifier, volume control and 1/4" and 1/8" headphone jacks
- Cough button and mic-on LED
- **MiniPod:** headphone amplifier with level control and both 1/4" and 1/8" headphone jacks



MINIPOD-MAXX



GUESTPODII

GUESTPOD-II **\$195.00**
MINIPOD-MAXX **\$195.00**
MINIPODPS **\$20.00**



BSW
CUSTOMER
FAVORITE

Critically Acclaimed Audio-Technica Headphones

These headphones offer sonic accuracy and long-term comfort while appealing to any budget. All feature a closed-back, around the ears design for excellent sound isolation in loud environments and large, high performance drivers.

- **ATH-M20x:** great for tracking and mixing with enhanced low frequency response (15 Hz to 20 kHz)
- **ATH-M30x:** wide frequency response (15 Hz to 22 kHz) with excellent mid-range definition
- **ATH-M40x:** tuned flat for accurate sound monitoring across its entire frequency range (15 Hz to 24 kHz)
- **ATH-M50x:** Superior sonic performance with exceptional clarity throughout an extended frequency range (15 Hz to 28-kHz) and deep, accurate bass response
- **ATH-M60xa:** On-ear design for excellent isolation and fit with premium, memory foam earpads and headband

ATHM20X **\$49.00**
ATHM30X **\$79.00**
ATHM40X **\$119.00**
ATHM50X **\$169.00**
ATHM60XA **\$219.00**



Industry-Favorite Studio Headphone

The Sony MDR 7506 delivers a wide frequency response of 10 Hz-20 kHz in a comfortable, sealed-ear format that provides excellent isolation. It offers a miniplug connector with 1/4" screw-on adapter and low 24 ohm impedance.

7506 List-\$130.00 **\$99.99**



BSW
CUSTOMER
FAVORITE

SONY



KNS-6402



KNS-8402

Great for Critical Listening and More

KRK's KNS 6402 and KNS 8402 closed-back, circumaural headphones deliver ultra-accurate sound and superb stereo imaging for critical listening and other applications. They're designed for long-wearing comfort and offer impressive isolation to help prevent sound bleed and to keep distracting noise at bay.

- Wide frequency response for detailed sound
- Superb clarity with ultra-low distortion, even at high SPL
- Up to 26 dBA (KNS-6402) and 30 dBA (KNS-8402) of isolation
- 36 ohms rated impedance

KNS-6402 List-\$99.00 **\$99.00**
KNS-8402 List-\$149.00 **\$149.00**



HEADPHONES

For recording projects, critical listening or to enjoy some music, a good pair of headphones is a valued companion. You'll find plenty to choose from here.

Ultimate Headphone 5-Pack

NEW



Best-Ever Headphone 5-Pack

The BSW Aircan 5 pack dynamic broadcast headphones deliver studio-quality sound at an affordable price. Featuring powerful 40mm drivers, they deliver clarity, balance, and accurate bass response even at lower listening volumes. The drivers and the closed-back design make Aircans ideal for on-air broadcast, production, podcasting, and mixing. As a bonus, they sport an adjustable headband and ergonomic earcups for even more comfort. Leatherette headband and ear pads for that new car feel (but not smell). Detachable/replaceable headphone cable with anti-shock-noise reducing coiling. Cutting back on handling noise and vibration transferred through the cable. Fancy!

BSW-AIRCANS-5PACK	5-Pack headphones	\$149.00
BSW-AIRCANS-CABLE	Replacement headphone cable	\$9.99

5 FOR \$149.99
(NOT A TYPO)



BSW
CUSTOMER
FAVORITE

Top-Notch Monitoring Headphone

The Sennheiser HD280 Pro closed-ear headphone boasts superb audio quality and a collapsible design with swiveling ear cups for maximum flexibility.

- Dynamic stereo headphone
- Accurate, linear sound reproduction
- 64-ohm impedance
- Wide 8 Hz–25 kHz frequency response
- Up to 32 dB of ambient noise attenuation
- Single-sided, coiled cable with mini plug and 1/4" adapter

HD280PRO	\$99.95
HD200PRO	\$79.95
HD300PRO	\$199.95
HD300PROTECT	\$229.95



Shure SRH Headphone Series

- **SRH840:** optimized for studio recording
- **SRH440:** enhanced frequency response
- **SRH240A:** full bass with detailed highs.
- **SRH1540:** premium closed-back design
- **SRH1840:** open-back design and superb acoustic performance

SRH240A-BK	List — \$75.00	\$59.00
SRH440A	List — \$125.00	\$99.00
SRH840A	List — \$186.00	\$149.00
SRH1540-BK	List — \$624.00	\$499.00
SRH1840-BK	List — \$624.00	\$499.00



Top Wireless Receivers from Lectrosonics

Two-Channel Digital Slot Receiver

Lectrosonics' DSR digital receiver delivers high level RF and audio performance with a versatile feature set in a compact design for camera mounted applications.

- Two independent channels, compact design
- Vector diversity for superior performance
- Latest generation of SR Series: compatible with huge existing ecosystem
- Compatible with D2, HDM, Duet and DCHX Digital modes and all hybrid modes
- 24 bit/48 kHz digital for flawless audio
- Analog and AES3 digital audio outputs
- AES 256-bit, CTR mode encryption
- USB input for firmware updates and data transfer
- Operates in A1B1 band (470.100 - 614.375 MHz)

DSR-A1B1 Two Channel Digital Slot Receiver **\$2,989.00**



Compact Four-Channel Digital Slot Receiver

The Lectrosonics DSR4 digital receiver provides superb RF and audio performance with a versatile feature set for field and location production.

- Four independent channels, compact design
- Two diversity options for maximum flexibility
- 24 bit/48 kHz digital for flawless audio
- AES 256-bit, CTR mode encryption
- High IP3 performance of +15 dBm for tough RF environments
- Analog and AES3 digital audio outputs
- External DC powering options
- USB input for firmware updates and data transfer
- Operates in A1B1 band (470.100 - 614.375 MHz)

DSR4-A1B1 **\$4,449.00**



Portable Two-Channel Digital Receiver

Lectrosonics' portable DCR822 digital receiver is ideal for field and location production. It features an RF spectrum analyzer and SmartTuner to alleviate interference problems in an increasingly congested RF spectrum.

- Dual independent channels, compact design
- Vector Diversity with 2 RF front ends per channel for superior performance
- 24 bit/48 kHz digital for flawless audio
- High IP3 performance of +15 dBm for tough RF environments
- Analog and AES3 digital audio outputs
- 4 AA internal batteries or external DC powering options
- On-board recording via microSDHC card
- Operates in A1B1 band (470.100 - 614.375 MHz)

DCR822-A1B1 List \$5,233.00 **\$3,749.00**



THE ULTIMATE AUDIO SOLUTION



FOR CONTENT CREATORS

NOW COMPATIBLE WITH RØDE WIRELESS MICROPHONES



RØDECASTER SERIES



BSW, we know podcast.
Call for your best RØDE price
1-800-426-8434 • www.BSWUSA.com



Great Podcast and Live Streaming Solutions

Compact Audio Production Studio for Content Creators

The RØDE RØDEcaster Duo is a compact powerful all-in-one audio production solution for podcasters and content creators. It features two high-quality Neutrik combo inputs for connecting microphones, instruments or line-level devices, a 3.5mm TRRS headset input, and integrated wireless receiver for connecting RØDE wireless microphones for serious versatility.

Ultra-low-noise, high-gain Revolution Preamps and studio-grade APHEX audio processing deliver pristine audio quality, with dual USB-C interfaces for connecting two computers or mobile devices, as well as Bluetooth connectivity for seamless phone call integration.

The RØDEcaster Duo is fully customizable, with seven individually assignable channels and six programmable SMART pads for on-the-fly triggering of sound or voice FX and other actions.

RØDECASTER-DUOW	Fully integrated audio production studio (white)w	List-\$599.00	\$499.00
RØDECASTER-DUO	Fully integrated audio production studio	List-\$599.00	\$499.00
3I1510-6-RD	SKB case for Duo		\$169.99



NEW

RØDECASTER-DUOW

3I1510-6-RD



Awesome Audio Interface and Video Capture Card

RØDE's Streamer X is a professional video capture card, audio interface and control surface integrated in one compact device that makes content creation impressively easy. Call a BSW GearHead or visit bswusa.com for all the details.

- Professional video capture card, audio interface and control surface
- 4K30 video capture and 4K60 pass-through via HDMI
- Studio-grade Revolution Preamp with Neutrik combo jack
- 3.5mm TRRS input for connecting headsets
- Integrated wireless receiver for connecting RØDE Series IV wireless devices
- Dual USB-C interfaces for connecting to two computers or mobile devices
- Four SMART pads for triggering sounds, voice FX and other actions on a computer
- Compatible with RØDE software suite, including UNIFY, RØDE Central and RØDE Connect

STREAMER-X	Integrated audio interface/video capture card	List-\$499.00	\$399.00
-------------------	-----------------------------------------------	---------------	-----------------



Content Creation Made Easy with RØDEcaster Pro II

RØDE's RØDEcaster Pro II integrated audio production studio offers nine individually assignable channels, powerful processing/effects, multi-track or stereo recording, dual USB-C interfaces, advanced Bluetooth connectivity and much more. Remarkably easy to use, it's ideal for podcasters, streamers and other content creators.

- Ultra-low-noise, high-gain Revolution Preamps
- Nine individually assignable channels with six physical faders and three virtual faders
- High-performance quad-core audio engine
- Studio-grade APHEX audio processing and on-board effects
- Eight fully programmable SMART pads with bank switching
- Dual USB-C interfaces and advanced Bluetooth connectivity
- Multitrack or stereo recording to a microSD™ card, USB storage device or computer

RØDECASTER-PRO-IIW	Podcast production console (white)	List-\$999.00	\$699.00
RØDECASTER-PRO-II	Podcast production console	List-\$999.00	\$699.00
3I1813-7-RP2	Case for RØDEcaster Pro II		\$259.00



NEW

RØDECASTER-PRO-IIW

